

Determination of Sensitive Transmission Lines Due to the Effect of Protection System Hidden Failure in a Critical System Cascading Collapse

N. A. Salim, M. M. Othman, I. Musirin, and M. S. Serwan

Abstract—Protection system hidden failures have been identified as one of the main causes of system cascading collapse resulting to power system instability. In this paper, a systematic approach is presented in order to identify the probability of a system cascading collapse by taking into consideration the effect of protection system hidden failure. This includes the accurate calculation of the probability of hidden failure as it will provide significant impinge on the findings of the probability of system cascading collapse. The probability of a system cascading collapse is then used to identify the initial tripping of sensitive transmission lines which will contribute to a critical system cascading collapse. Based on the results obtained from this study, it is important to decide on the accurate value of the hidden failure probability as it will affect the probability of a system cascading collapse.

Keywords—Critical system cascading collapse, hidden failure, probability of cascading collapse, sensitive transmission lines.

I. INTRODUCTION

IN today's deregulated power system, the aim of a utility company is to provide the electrical energy in a reliable, safe and economical form. Therefore, each utility company is competing among each other in order to generate high quality of electricity in a cost-effective manner. Thus, utility companies have to minimize any disturbances that will affect the performance of a power system [1]. Power grids suffer sporadic contingencies, some of which are sufficiently large as to impact a considerable fraction of the grid infrastructure. The catastrophic disruption of a power grid is often triggered by a set of cascading collapse while the grid is generally operating near critical loading [2].

Among the turbulences that would be catastrophic to a power system is due to the effect of system cascading collapse. Several severe blackouts that had happened all over the world recently, have resulted in severe consequences to the national economy and social life [3]. The most recent blackout

had happened in India on the 30th and 31st July 2012, where more than 620 million people throughout the country were affected [4], which is equivalent to 9% of the world's total population. Some other major blackouts afflicted by the system cascading collapse can be found in [5,7]. The essence of blackout resulted from system cascading collapse cannot be deeply realized by traditional power system theoretical analysis, therefore, new approach are needed to investigate the challenges of large grid security in order to prevent any disturbances to the power system.

Various models have been built to anticipate the impact of cascading collapse in complex network system. Basically, these models can be classified into three groups, which are the probabilistic model e.g. CASCADE and branching model, the complex network model e.g. dynamic flow model and also the physical simulation model e.g. Oak-Ridge-PSERC-Alaska (OPA) and Power System Analyzer (PSA) model. Dobson [8] applied the probabilistic model, using the branching technique to determine the distribution of system cascading collapse for an initial failure. The similar technique used can be found in [9], [10]. Pierre *et al.* [11] developed an integrated probabilistic approach and the complex network model where it is capable of handling the coupling between events in cascading failure and the dynamic response of the grid to initiating perturbations. The related technique can also be found in [12], [13]. Carreras *et al.* [14] uses the physical simulation model of OPA to identify the overloaded transmission lines with the highest probability in order to recognize the critical lines which contribute to a high probability of cascading collapse. Shi *et al.* [15] performs the analysis of cascading collapse by taking into account the effect of hidden failure to a protection relay. The same approach is also used in [16], [17].

Based on the literature study that has been performed, it is important to analyze the effect of system cascading collapse as the impact to a power system is significant. For that reason, this paper proposes a computational effective approach of system cascading collapse. The analysis is performed to study the impact of different value of hidden failure probability to the average probability of cascading collapse and sensitive transmission lines. In this study, the determination of sensitive transmission lines is conducted according to the criticality of the system cascading collapse. The IEEE RTS-79 is used as a case study in order to validate the effectiveness of the proposed technique considered in the assessment of system

This work was supported in part by Research Management Institute (RMI) and Ministry of Science, Technology and Innovation, Malaysia (MOSTI) under Grant 03-01-01-SF0476.

N. A. Salim is with the Faculty of Electrical Engineering, Universiti Teknologi MARA, 13500 Pulau Pinang, Malaysia. (e-mail: ashida_amani@yahoo.com).

M. M. Othman and I. Musirin are with the Faculty of Electrical Engineering, Universiti Teknologi MARA, 40450 Shah Alam, Malaysia. (e-mail: mamat505my@yahoo.com).

M. S. Serwan is with the Advanced Power Solution Sdn. Bhd., Worldwide Business Centre, Jalan Tinju 13/50, 40000 Shah Alam, Malaysia. (e-mail: serwan@aps-my.com).

cascading collapse. The assessment of cascading collapse needs to be performed consistently in the power system operation and planning so that a power system could be prevented from any kind of catastrophic events. Consequently, it is crucially important for the utility and power system planner to recognize the sensitive transmission lines that could cause significant impact of system cascading collapse.

II. IMPACT OF HIDDEN FAILURE IN A PROTECTION SYSTEM

Protection system hidden failure has been identified as one of the main reasons in the distribution of power system turbulence and even causing to a power system failure. The hidden failure of a protection system is defined as a permanent deficiency of a relay unit or a protection system which will incorrectly trip and remove the circuit elements as a direct consequence of another switching event [18]. This might cause to some component outages that are dependent on each other. Nevertheless, the hidden failures cannot be detected during normal system operating condition [19]. Prior to that, an initial component outage might results to a cascading tripping by distressing the neighboring components suffered with hidden failure that will become a causative factor in spreading the disturbances and finally causing the entire system to collapse. This implies that when a fault or overloads occur, it will expose and causing unnecessary outages to the other equipment. The occurrence of hidden failure in a protective system will exaggerate stress in a system which makes it even bad and finally reduces the level of system reliability. Based on the excerpt taken from the North American Electric Reliability Corporation (NERC) report, more than 70% of the major disturbances yielding to a power system blackout were caused by the relay hidden failures [13]. In general, the hidden failure of a protective system may not achieve in accordance to the designated function and this will deviate from the propagation of disturbance which may cause incorrect tripping to the other relay units. The hidden failure of a protective system usually occurs due to the effect of line overloading, reverse power flow and fault.

III. DETERMINATION OF SENSITIVE TRANSMISSION LINES BASED ON THE CRITICAL CASCADING COLLAPSE

This section will discuss on the methods involved to evaluate the probability of cascading collapse by taking into account different case studies of hidden failure probability. According to the NERC report, 400 events of cascading collapse caused by the hidden failure of a line protective relay happened in the past 16 years that is from 1984 until 1999 [20]. Although the probability of occurrence for one exposed line tripping event due to hidden failure is very small, however, it cannot be neglected due to its catastrophic effect on a power system condition. The probability of an exposed line tripping event caused by the hidden failure can be calculated by using (1).

$$p_{HF} = \frac{E}{y \times d \times h \times m \times s} \quad (1)$$

where

E is the total number of cascading collapse events due to hidden failure.

y is the total number of years where the events of cascading collapse occurred.

d is the total number of days in a year i.e. 365 days.

h is the total number of hours in a day i.e. 24 hours.

m is the total number of minutes in an hour i.e. 60 minutes.

s is the total number of seconds in a minute i.e. 60 seconds.

For that reason, the probability of an exposed line tripping event due to hidden failure according to the historical information [21] is given by,

$$p_{HF} = \frac{400 \text{ events}}{16 \text{ years} \times 365 \text{ days} \times 24 \text{ hour} \times 60 \text{ minutes} \times 60 \text{ second}} = 8 \times 10^{-7}$$

Then, the probability increases linearly until it reaches to $p_{HF} = 1$ at 1.4 of its line limit as depicted in Fig. 1. The probability remains unchanged as $p_{HF} = 1$ for line loading that is above 1.4 of line limit [15]. It is important to provide an accurate calculation of exposed line tripping probability caused by the hidden failure, p_{HF} since this will assist the utility in providing accurate decision in a power system planning. In this study, three different case studies of hidden failure probability which are $p_{HF} = 8 \times 10^{-7}$, $p_{HF} = 1 \times 10^{-12}$ and $p_{HF} = 1 \times 10^{-2}$ [18] is taken into consideration for the analysis of cascading collapse. For each case study, the results of average probability of cascading collapse will be used to further examine the sensitive transmission lines that could cause critical cascading collapse to a power system. The proposed technique begins with an initial tripping event of a transmission line. Followed by that, the power flow solution is performed by taking into account 10% increment of the total system loading condition. Then, calculate the probability of incorrect tripping due to hidden failure, p_{HF} for each exposed lines connected next to the tripping line.

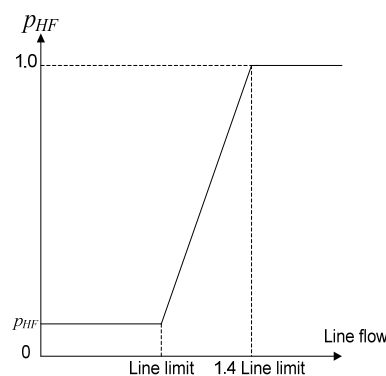

Fig. 1 Probability of an exposed line incorrect tripping due to the effect of hidden failure

Perform random tripping on the exposed lines with p_{HF} higher than the chosen value of $p_{HF} = 8 \times 10^{-7}$. In this case study,

$p_{HF} = 8 \times 10^{-7}$ is obtained based on the historical data of transmission line tripping events that caused by the effect of hidden failure. This will be used as a point of reference by comparing it with the other case studies which $p_{HF} = 1 \times 10^{-12}$ and $p_{HF} = 1 \times 10^{-2}$ in order to examine its significant impact to the probability of cascading collapse and sensitive transmission lines. Concurrently, calculate the conditional probability of tripping, P_{cj} [21] by using (2).

$$P_{cj} = \prod p_{Hj} \prod q_{Hj} \quad (2)$$

where

p_{Hj} is the probability of exposed transmission line encountering the random tripping event in state j .

q_{Hj} is the probability of the exposed transmission line not encountering the random tripping event in state j .

This process is repeated until there is no exposed line to perform the random tripping event. After that, (3) is used to calculate the tripping events probability, P_{ci} by considering all of the conditional probability of tripping, P_{cj} .

$$P_{ci} = \prod_{j=1}^{NJ} P_{cj} \quad (3)$$

where NJ is the total number of system state at initial tripping, i .

For the chosen initial transmission line tripping, the simulation is repeated for $N = 1000$ times so as to obtain the average probability of cascading collapse, \hat{P}_{Ci} that can be calculated using (4).

$$\hat{P}_{Ci} = \frac{1}{N} \sum_{n=1}^N P_{Ci,n} \quad (4)$$

where N is the total number of iterations to perform the random tripping i .

Then, the entire simulation is repeated until the last initial line tripping has been obtained. Collect the average probability of cascading collapse, \hat{P}_{Ci} for all of the initial line tripping. Hence, apply (5) in order to calculate the estimated average probability of cascading collapse $\mu(\hat{P}_{Ci})$ for identifying the sensitive transmission lines contributing to a critical system cascading collapse.

$$\mu(\hat{P}_{Ci}) = \frac{1}{L} \sum_{l=1}^L \hat{P}_{Ci,l} \quad (5)$$

where L is the total number of steps for the increase of total loading condition.

Rank the $\mu(\hat{P}_{Ci})$ in an ascending order to identify the sensitive transmission lines at initial tripping. The sensitive transmission lines are obtained by referring to the initial line

tripping that cause to a sudden increase of $\mu(\hat{P}_{Ci})$.

IV. RESULTS AND DISCUSSION

This section will discuss on the estimated average probability of system cascading collapse, $\mu(\hat{P}_{Ci})$ that takes into consideration the effects of hidden failure in a relay protection system. The total loading condition is increased by 10% while maintaining a constant power flow at all buses. An initial tripping event of transmission line is performed for every increased of total loading condition. The simulation is repeated for 1000 times to obtain the accurate \hat{P}_{Ci} . Further analysis was performed on the results of $\mu(\hat{P}_{Ci})$ based on three different cases of hidden failure which are $p_{HF} = 8 \times 10^{-7}$, $p_{HF} = 1 \times 10^{-12}$ and $p_{HF} = 1 \times 10^{-2}$.

The proposed technique is tested on the IEEE Reliability Test System 1979 (IEEE RTS-79) as shown in Fig. 2. The total load for the system is 2850MW and the total generation capacity is 3405MW. This system has 32 generating units, varies from 12MW to 400MW, 20 load buses and 38 transmission lines. The probability of a system cascading collapse is acquired by repeating the procedure of cascading collapse for N times and taking into consideration an initial tripping event of a transmission line.

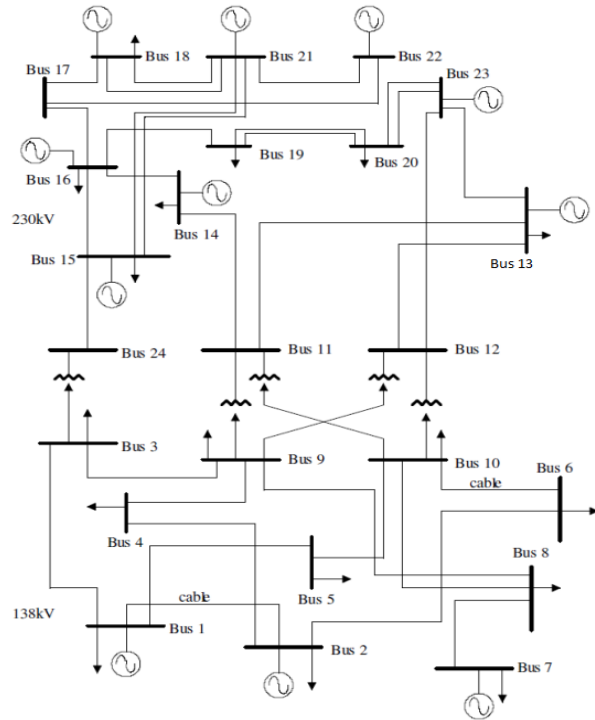

Fig. 2 Single line diagram for IEEE RTS-79

The estimated average probability of system cascading collapse, $\mu(\hat{P}_{Ci})$ is used to identify the sensitive initial transmission line tripping which would have high tendency to cause a critical system cascading collapse. Based on the three

case studies of the p_{HF} performed on the IEEE RTS-79, the initial transmission line tripping with the highest value of $\mu(\hat{P}_{C_i})$ is identified as the sensitive transmission line, which indicates as the criticality of a system cascading collapse. The results of the sensitive transmission lines obtained based on the critical system cascading collapse for the IEEE RTS-79 is depicted in Table I and Fig. 3.

3-9	0.13611	2-4	0.18120	3-9	0.13611
2-4	0.13417	1-5	0.17969	2-4	0.13417
18-21	0.13296	17-22	0.17913	18-21	0.13296
17-22	0.13277	18-21	0.17856	17-22	0.13277

For the three case studies of $p_{HF} = 8 \times 10^{-7}$, $p_{HF} = 1 \times 10^{-12}$ and $p_{HF} = 1 \times 10^{-2}$, the $\mu(\hat{P}_{C_i})$ was ranked in an ascending order to identify the sensitive transmission lines that will cause to a critical system cascading collapse. The results, as shown in Table I, indicate that the sensitive transmission line 12-13, line 14-16 and line 12-23 present extensively large value of $\mu(\hat{P}_{C_i})$ compared to the remaining lines in the system. This can also be observed in Fig. 3. In Fig. 3, the initial tripping of sensitive transmission line 12-13, line 14-16 and line 12-23 are causing to a abrupt increase of $\mu(\hat{P}_{C_i})$ which implies that the system are experiencing a critical cascading collapse. As results of this condition, major safety measure should be given to avoid from the disconnection of these sensitive transmission lines which will cause to a critical system cascading collapse.

TABLE I
SENSITIVE TRANSMISSION LINES DUE TO THE EFFECT OF HIDDEN FAILURE FOR IEEE-RTS79

$p_{HF} = 1 \times 10^{-12}$		$p_{HF} = 8 \times 10^{-7}$		$p_{HF} = 1 \times 10^{-2}$	
Initial Line Tripping	$\mu(\hat{P}_{C_i})$ (per unit)	Initial Line Tripping	$\mu(\hat{P}_{C_i})$ (per unit)	Initial Line Tripping	$\mu(\hat{P}_{C_i})$ (per unit)
12-13	0.35740	12-13	0.35579	12-13	0.24756
14-16	0.22384	14-16	0.23058	14-16	0.16518
12-23	0.19249	12-23	0.19084	12-23	0.1412
1-5	0.13625	3-9	0.18691	1-5	0.13625

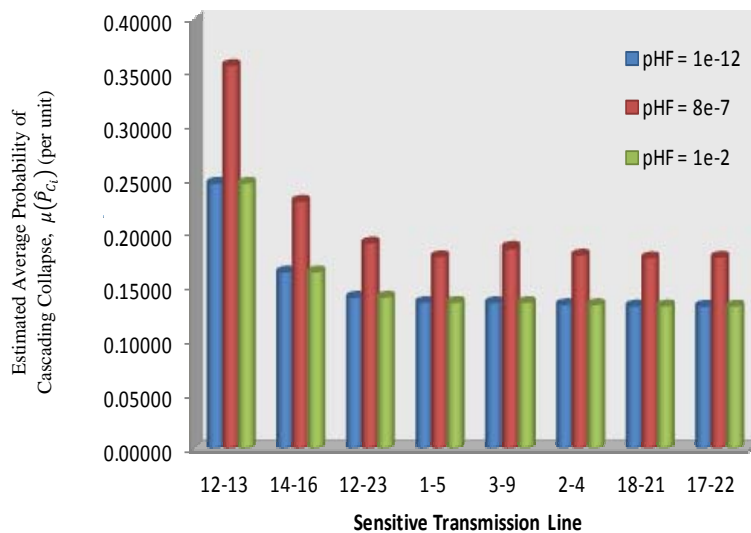

Fig. 3 Estimated average probability of cascading collapse $\mu(\hat{P}_{C_i})$ of each sensitive transmission line for IEEE RTS-79

Fig. 4 shows the $\mu(\hat{P}_{C_i})$ for the three case studies of p_{HF} based on the initial tripping of sensitive transmission line stated in Table I. In Fig. 4, the $p_{HF} = 8 \times 10^{-7}$ provides the highest value of $\mu(\hat{P}_{C_i})$ for all the initial lines tripping compared to the other two probabilities, which are $p_{HF} = 1 \times 10^{-12}$ and $p_{HF} = 1 \times 10^{-2}$. This implies that the actual information of

cascading collapse events that caused by the protection system hidden failure is important to be taken into account in the p_{HF} calculation since it will provide a significant difference and an accurate result of $\mu(\hat{P}_{C_i})$.

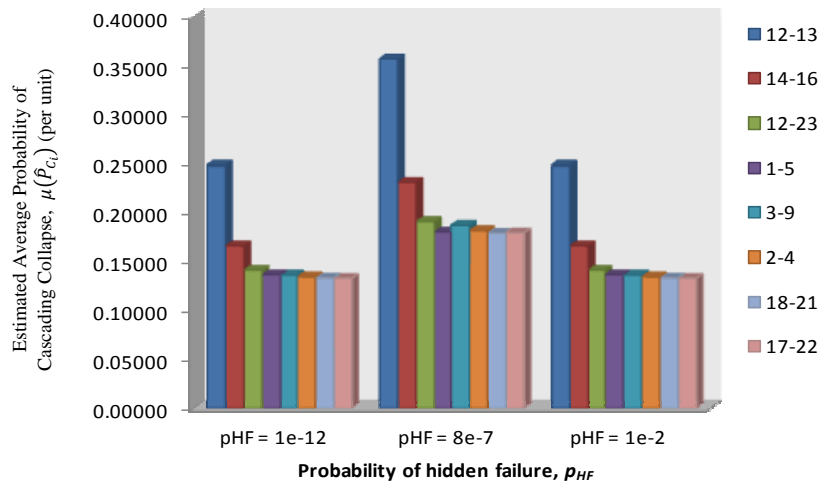

Fig. 4 Estimated average probability of cascading collapse $\mu(\hat{p}_{C_i})$ for each case study of p_{HF} for IEEE RTS-79

V. CONCLUSION

Increasing amount of critical system cascading collapse that have occurred recently has revealed that there is an urgent need for advanced technologies required by the utility and system planning. The critical cascading collapse can happen by just an initial tripping event of a transmission line. This paper has discussed on the estimated average probability of cascading collapse, performed by assuming that each transmission line has a different load dependent probability of incorrect tripping due to the effect of protection system hidden failure. In this study, the estimated average probability of cascading collapse increases as the probability of hidden failure is set to a lower value. Alternatively, a higher value of the hidden failure probability will decrease the value of the estimated average probability of cascading collapse. For that reason, it is important to decide the correct value of the hidden failure probability as it could influence the selection of the sensitive transmission line that could lead to critical cascading collapse. Thus, the study is useful in assisting the utility and system planner to identify the sensitive transmission line that would cause large impact of system cascading collapse.

ACKNOWLEDGMENT

The authors would like to thank the Ministry of Higher Education Malaysia (MOHE), Research Management Institute (RMI), Universiti Teknologi MARA, Malaysia and the Ministry of Science, Technology and Innovation, Malaysia (MOSTI) under Grant 03-01-01-SF0476, Malaysia for the financial support of this research. We also would like to express our sincere gratitude to Professor Mahmud Fotuhi Firuzabad from Sharif University of Technology, Iran for his continuous support in completing this research.

REFERENCES

[1] G. O. Q. Q. L. Mili, A.G.Phadke, "Risk assessment of catastrophic failures in electric power systems," *Int. J. Critical Infrastructures*, vol. 1, p. 25, 2004.

[2] Thomas L. Baldwin, Magdy S. Tawfik, and M. McQueen, "Contingency Analysis of Cascading Line Outage Events," in *Power Systems Conference 2011*, pp. 1-8.

[3] T. Jingzhe, G. Deqiang, X. Huanhai, and W. Zhen, "Cascading Failure and Blackout Risk Analysis of AC/DC Power System - The Impact of AC/DC Interconnection Mode and Capacity Distribution," in *2012 Asia-Pacific Power and Energy Engineering Conference (APPEEC)*, 2012, pp. 1-5.

[4] H. Pidd. (2012). India blackouts leave 700 million without power. Available: <http://www.guardian.co.uk/world/2012/jul/31/india-blackout-electricity-power-cuts>.

[5] M. Vaiman, K. Bell, Y. Chen, B. Chowdhury, I. Dobson, P. Hines, M. Pappic, S. Miller, and P. Zhang, "Risk Assessment of Cascading Outages: Methodologies and Challenges," *IEEE Transactions on Power Systems*, vol. 27, pp. 631-641, 2012.

[6] J. M. Ian Dobson, Chen-Ching Liu, "Fast Simulation, Monitoring and Mitigation of Cascading Failure," *Power Systems Engineering Research Center* 2010.

[7] K. Yamashita, L. Juan, Z. Pei, and L. Chen-Ching, "Analysis and control of major blackout events," in *IEEE/PES Power Systems Conference and Exposition, 2009. PSCE '09, 2009*, pp. 1-4.

[8] I. Dobson, "Estimating the Propagation and Extent of Cascading Line Outages From Utility Data With a Branching Process," *IEEE Transactions on Power Systems*, vol. 27, pp. 2146-2155, 2012.

[9] I. Dobson, B. A. Carreras, and D. E. Newman, "Branching Process Models for the Exponentially Increasing Portions of Cascading Failure Blackouts," in *Proceedings of the 38th Annual Hawaii International Conference on System Sciences, 2005. HICSS '05, 2005*.

[10] I. Dobson, B. A. Carreras, and D. E. Newman, "A branching process approximation to cascading load-dependent system failure," in *Proceedings of the 37th Annual Hawaii International Conference on System Sciences, 2004*.

[11] P. Henneaux, P.-E. Labeau, and J.-C. Maun, "A level-1 probabilistic risk assessment to blackout hazard in transmission power systems," *Reliability Engineering & System Safety*, vol. 102, pp. 41-52, 2012.

[12] W. Guang-zeng, K. Xiao-feng, Z. Cheng-zhi, X. Jian-Ping, and C. Yi-jia, "Identification of key lines in complex power grid based on power flow entropy," in *2010 China International Conference on Electricity Distribution (CICED)*, 2010, pp. 1-6.

[13] I. Dobson, B.A.Carreras, V.E.Lynch, and D.E.Newman, "Complex systems analysis of series of blackouts: Cascading failure, critical points, and self-organization," in *Bulk Power System Dynamics and Control - VI, 2007*, pp. 438-451.

[14] B. A. Carreras, D. E. Newman, and I. Dobson, "Determining the Vulnerabilities of the Power Transmission System," in *2012. 45th Hawaii International Conference on System Science (HICSS)*, pp. 2044-2053.

[15] S. Zhongying, S. Libao, N. Yixin, Y. Liangzhong, and M. Bazargan, "Identifying Chains of Events during Power System Cascading Failure,"

- in 2011 Asia-Pacific Power and Energy Engineering Conference (APPEEC), 2011, pp. 1-4.
- [16] Z. Jingjing and D. Ming, "Summary of research on hidden failures in protection systems," in International Conference on Electrical Machines and Systems, 2008. ICEMS 2008, pp. 870-872.
- [17] Y. Fang, A. P. S. Meliopoulos, G. J. Cokkinides, and Q. B. Dam, "Effects of Protection System Hidden Failures on Bulk Power System Reliability," in 38th North American Power Symposium, 2006, NAPS 2006, pp. 517-523.
- [18] N. A. Salim, M. M. Othman, I. Musirin, and M. S. Serwan, "Cascading Collapse Assessment Considering Hidden Failure," in 2011 First International Conference on Informatics and Computational Intelligence (ICI), 2011, pp. 318-323.
- [19] G. Chen, Z. Y. Dong, D. J. Hill, G. H. Zhang, and K. Q. Hua, "Attack structural vulnerability of power grids: A hybrid approach based on complex networks," *Physica A: Statistical Mechanics and its Applications*, vol. 389, pp. 595-603, 2010.
- [20] Nur Ashida Salim, Muhammad Murtadha Othman, Ismail Musirin, and M. S. Serwan, "Risk Assessment of Cascading Collapse Considering the Effect of Hidden Failure," in 2012 IEEE International Conference on Power and Energy, Kota Kinabalu, Sabah, Malaysia, 2012, pp. 772-777.
- [21] P. M. Subcommittee, "IEEE Reliability Test System," *IEEE Transactions on Power Apparatus and Systems*, vol. PAS-98, pp. 2047-2054, 1979.



Nur Ashida Salim received her MEng (Power System & Electrical Energy) from Universiti Malaya in 2006 and Bachelor in Electrical Engineering (Hons.) from Universiti Teknologi MARA in 2003. She is a lecturer at Universiti Teknologi MARA Pulau Pinang and currently pursuing her PhD in Universiti Teknologi MARA, Shah Alam. Her research interests are power system reliability, power system planning and artificial intelligence.



Assoc. Prof. Dr. Muhammad Murtadha Othman received his Ph.D. in Electrical, Electronic and Systems Engineering in 2006 from Universiti Kebangsaan Malaysia and MSc degree from Universiti Putra Malaysia in 2000. He currently lectures at Universiti Teknologi MARA, Malaysia. His research interests are artificial intelligence, power system reliability, power system stability, transfer capability assessment and energy efficiency.



Assoc. Prof. Dr. Ismail Musirin received his PhD in Electrical Engineering, Universiti Teknologi MARA, Malaysia in 2005 and MSc in Pulsed Power Technology, University of Strathclyde, Glasgow United Kingdom, 1992. He currently lectures at Universiti Teknologi MARA, Malaysia. His research interests are Application of Artificial Intelligence in Power System Optimization, Green and Renewable Energy, Loss Minimization and Reactive Power Control.



Mohd Salleh Serwan received his Bachelor of Science in Mechanical Engineering from University of Southwestern Louisiana, US. He has 30 years working experience as an engineer. He used to work with National Electricity Board, Malaysia and Tenaga Nasional Berhad, Malaysia. Currently, he's attached to Advanced Power Solution Sdn. Bhd., Malaysia as a software development and software support.