

# Analytical Model for Predicting Whole Building Heat Transfer

Xiaoshu Lu and Martti Viljanen

**Abstract**—A new analytical model is developed which provides close-formed solutions for both transient indoor and envelope temperature changes in buildings. Time-dependent boundary temperature is presented as Fourier series which can approximate real weather conditions. The final close-formed solutions are simple, concise, and comprehensive. The model was compared with numerical results and good accuracy was obtained. The model can be used as design and control guidelines in engineering applications for analysing mechanical heat transfer properties for buildings.

**Keywords**—Analytical model, heat transfer, whole building.

## I. INTRODUCTION

**M**ODELLING whole building's heat transfer is important for understanding and predicting building thermal behaviours in order to provide techniques for designing and analysing problems such as energy demands, passive design, environmental comfort and the response of control in a building. Over the decades, there have been numerous building heat transfer models for such purposes [1]. Most whole building heat transfer programs are numerical models. This is due to the fact that even for building's multiple layered envelope alone, the heat transfer problem already remains too big and complex to analytically solve. However, analytical models are very useful in design, analysis and optimisation of complex interactions of the physical processes in buildings. Furthermore, an important final step to promote the practical use of any model, including numerical models, is to condense it for engineering applications. And this can only be accomplished by identifying the fundamental physical processes by means of analytical methods.

One of the difficulties, as described previously, with the analytical models for whole building's heat transfer is relating heat conduction through building envelope which is often constructed with multiple layers. In general, heat conduction in a multiple layered composite slab does not accept simple and closed-formed solutions. Mathematically, four classes of analytical techniques are often used to solve for a heat conduction problem: finite integral transform which is often adopted for single layer material, Green's functions, orthogonal expansions and Laplace's transform [2,3]. Concerning the techniques of Green's function and orthogonal

expansions, an eigenvalue problem often accompanied. The associated eigenvalue problem may become much more complicated especially for a slab with many layers. The application of Laplace transform often yields residue computation. The calculation procedure is tedious if the slab has more than two layers [4].

Therefore, the eigenvalue or residue computation has always posed a challenge to analytical methods on solving heat conduction in composite slab. Above all, the heat transfer equation on building space adds complexity and computational expense to the system of simultaneous heat transfer equations for the whole building system. Therefore, most of the existing methods do not directly tackle the governing heat equations. Rather, response factor methods and conduction transfer function methods are most widely utilised for solving building heat transfer problems [5,6]. Numerical iteration is often needed to apply such methods. It is well known that a risk of numerical instability exists in using iterative programs.

More common models simplify the calculations by assuming steady-state heat transfer and zero thermal capacity of the building envelope [7]. These models lose the ability to simulate transient behaviours of the building system which are most important to characterise building physical processes of heat transfer. This paper presents an analytical model for predicting whole building heat transfer process. The model is simple, flexible, and driven by real weather conditions. The building setting dealt with by the developed model is similar as the one described in Boland's paper [8]. Comparison between the analytical and the numerical results shows a good accuracy of the developed analytical model.

## II. ASSUMPTIONS

In practice, heat transfer process for building has a strong three-dimensional character. However, the entire three-dimensional heat transfer for buildings is too complex to be performed by any analytical method and the physical process might be too complex for analysis and interpretation. Therefore, most analytical heat transfer models have simplified the building system. Even with the simplification, analytical methods are still troubled by the multiple layered envelope which does not permit analytical solutions to the heat conduction problem. In this paper, the following assumptions are made to the modelled building system:

- Building has only one zone.

Xiaoshu Lu is with Department of Civil and Structural Engineering, School of Engineering, Aalto University, PO Box 12100, FIN-02150, Espoo, Finland and Finnish Institute of Occupational Health, Finland (corresponding author; e-mail: xiaoshu@cc.hut.fi).

Martti Viljanen is with Department of Civil and Structural Engineering, School of Engineering, Aalto University, PO Box 12100, FIN-02150, Espoo, Finland (e-mail: martti.viljanen@hut.fi).

- Envelope consists of the walls, the roof, the windows and the floor foundation. The door belongs to a part of wall component.
- One-dimensional geometry is assumed for all the envelope components.
- Indoor air is well mixed with time-dependent temperature  $T_+(t)$ .
- Outdoor temperature is accounted by the combined effect of the outdoor dry bulb temperature and the solar radiation which is denoted as  $T_-(t)$ .
- Each component is an n-layer composite slab having constant thermal conductivity, diffusivity and density for each layer.
- Ventilation rate is constant throughout the calculation duration.
- Only steady-state heat transfer is considered for windows throughout the calculation duration.
- Boundaries for envelope components are the time-dependent indoor and outdoor temperatures. In particular, the boundaries for the floor and foundation are the indoor temperature and the time-dependent temperature which is placed under the foundation in the ground and denoted as  $T^{ground}(t)$ .

A schematic picture of the modelled building configuration is displayed in Fig. 1.

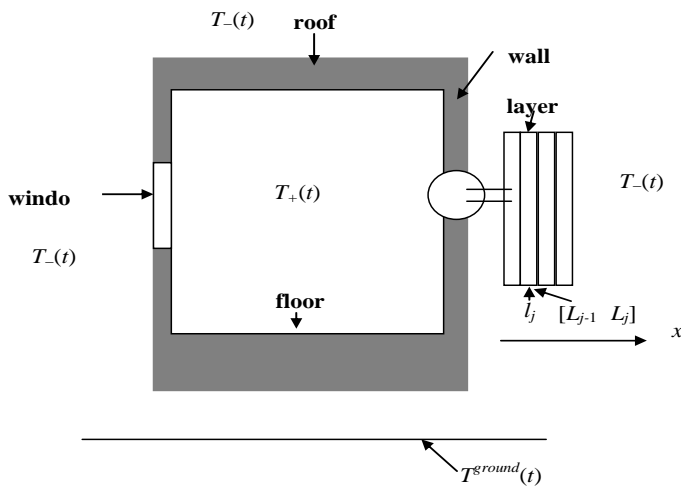

Fig. 1 Schematic picture of the modelled building configuration

### III. MODEL SOLUTION

#### A. General Model Equation for Building Envelope

Using the preceding assumptions, each building component is an n-layer composite slab having constant thermal conductivity, diffusivity and density for each layer (Fig. 1). The thermal conductivity, diffusivity and thickness are presented as  $\lambda_j$ ,  $k_j$  and  $l_j$ ,  $j = 1 \dots n$ . Just for a

demonstrational convenience, we provide the heat equation for a general n-layer slab first.

For an n-layer slab, we set the following notations  $l_0 = 0$  and  $L_j = l_0 + \dots + l_j$ ,  $j = 1 \dots n$ . Then the layer boundaries are  $[L_0 = 0, L_1]$ ,  $[L_1, L_2]$  and  $[L_{n-1}, L_n]$  (Fig. 1). The general heat conduction in an n-layer slab can be described by the following equations for the jth layer temperature  $T_j(t, x)$ :

$$\frac{\partial T_j}{\partial t} = k_j \frac{\partial^2 T_j}{\partial x^2}, \quad x \in [L_{j-1}, L_j], \quad j = 1 \dots n \quad (1a)$$

with boundary and initial conditions

$$-\lambda_1 \frac{\partial T_1}{\partial x}(t, L_0) = -\alpha_+(T_1(t, L_0) - T_+(t)) \quad (1b)$$

$$T_j(t, L_j) = T_{j+1}(t, L_j), \quad j = 1 \dots n-1 \quad (1c)$$

$$\lambda_j \frac{\partial T_j}{\partial x}(t, L_j) = \lambda_{j+1} \frac{\partial T_{j+1}}{\partial x}(t, L_j), \quad j = 1 \dots n-1 \quad (1d)$$

$$-\lambda_n \frac{\partial T_n}{\partial x}(t, L_n) = -\alpha_-(T_-(t) - T_n(t, L_n)) \quad (1e)$$

$$T_j(0, x) = 0, \quad x \in [L_{n-1}, L_n], \quad j = 1 \dots n \quad (1f)$$

For simplicity, zero initial temperature and perfect contact between layers are assumed. Surface convective and radiative heat transfer coefficients are  $\alpha_+$  and  $\alpha_-$ .

Heat transfer equations for all the building envelope components can be obtained from equation (1). The subscripts and superscripts are used to present different envelope components, for example,  $T^{wall}(t)$  for walls,  $T^{roof}(t)$  for roof, and  $T^{floor}(t)$  for floor and foundation in equation (1). For  $T^{floor}(t)$ , the equations exhibit somewhat differently in equation (1) where equation (1e) is changed as

$$T_n^{floor}(t, L_n) = T^{ground}(t) \quad (1g)$$

where  $T^{ground}(t)$  is the ground temperature beneath the building floor.

#### B. Equation for Indoor Air

For indoor temperature  $T_+(t)$ , the heat transfer equation is modelled as

$$\begin{aligned} C_{air} V \frac{dT_+}{dt} = & \sum_{wall} A^{wall} \alpha_+ (T_1^{wall}(t, L_0) - T_+) \\ & + A^{roof} \alpha_+ (T_1^{roof}(t, L_0) - T_+) + A^{floor} \alpha_+ (T_1^{floor}(t, L_0) - T_+) \\ & + \sum_{window} A^{window} U^{window} (T_-(t) - T_+) + \eta (T_-(t) - T_+) \end{aligned} \quad (2a)$$

$$T_+(0) = 0 \quad (2b)$$

where  $V$  presents the volume of the room,  $A$  the inner area of the component,  $C_{air}$  the thermal mass of the indoor air

(product of density and specific heat),  $U$  the glazing thermal transmittance coefficient, and  $\eta$  the ventilation rate of the building.

C. Weather Conditions

It is known that any function can be approximated as Fourier series in an extended interval. Therefore, for any real weather condition of outdoor temperatures, we can approximate it using Fourier series. Just for the sake of calculation simplification, we assume that both the outdoor and the ground temperatures change periodically as

$$T_-(t) = \cos(\omega t + \varphi) \tag{3a}$$

$$T^{ground}(t) = \cos(\omega t + \phi) \tag{3b}$$

Note that for general boundary temperatures  $T_-(t)$  and  $T^{ground}(t)$ , they can be presented as

$$T_-(t) = a_0 + \sum_{k=1}^{\infty} a_k \cos(\omega_k t + \varphi_k) \tag{4a}$$

$$T^{ground}(t) = b_0 + \sum_{k=1}^{\infty} b_k \cos(\omega_k t + \phi_k) \tag{4b}$$

Hence the corresponding solution can be expressed as the sum of solutions with boundary temperature of equation (3).

Furthermore, assume the boundary temperatures are as the complex form

$$T_-(t) = e^{i\alpha t + i\varphi} \tag{5a}$$

$$T^{ground}(t) = e^{i\omega t + i\phi} \tag{5b}$$

Clearly, the solution is the real part of the sought-after solution.

D. Model Solution

Applying Laplace transform on equation (1) we get

$$s\bar{T}_j = k_j \frac{\partial^2 \bar{T}_j}{\partial x^2} \quad x \in [L_{j-1}, L_j], \quad j = 1 \dots n \tag{6a}$$

with boundaries

$$-\lambda_1 \frac{\partial \bar{T}_1}{\partial x}(s, L_0) = -\alpha_+ (\bar{T}_1(s, L_0) - \bar{T}_+(s)) \tag{6b}$$

$$\bar{T}_j(s, L_j) = \bar{T}_{j+1}(s, L_j), \quad j = 1 \dots n-1 \tag{6c}$$

$$\lambda_j \frac{\partial \bar{T}_j}{\partial x}(s, L_j) = \lambda_{j+1} \frac{\partial \bar{T}_{j+1}}{\partial x}(s, L_j), \quad j = 1 \dots n-1 \tag{6d}$$

$$-\lambda_n \frac{\partial \bar{T}_n}{\partial x}(s, L_n) = -\alpha_- (\bar{T}_-(s) - \bar{T}_n(s, L_n)) \tag{6e}$$

where  $\bar{T}_j$  presents the Laplace transform of the building envelope components  $\bar{T}_j^{wall}$  and  $\bar{T}_j^{roof}$ , for instance.

A bar over function  $f(t)$  designates its Laplace transformation on  $t$  as [2]

$$\bar{f}(s) = \int_0^{\infty} e^{-s\tau} f(\tau) d\tau \tag{7}$$

The convolution property of Laplace transformation is given as [2]

$$\bar{f}(s) = \bar{f}_1(s) \bar{f}_2(s)$$

$$\text{then } f(t) = f_1(t) * f_2(t) = \int_0^t f_1(\tau) f_2(t - \tau) d\tau \tag{8}$$

Similarly, the Laplace transformation of equation (2) reads

$$s\bar{T}_+(s) = \sum_{wall} \beta^{wall} (\bar{T}_1^{wall}(s, L_0) - \bar{T}_+(s))$$

$$+ \beta^{roof} (\bar{T}_1^{roof}(s, L_0) - \bar{T}_+(s)) + \beta^{floor} (\bar{T}_1^{floor}(s, L_0) - \bar{T}_+(s))$$

$$+ \sum_{window} \beta^{window} (\bar{T}_-(s) - \bar{T}_+(s)) + \eta (\bar{T}_-(s) - \bar{T}_+(s)) \tag{9}$$

where  $\beta = \frac{A\alpha_+}{C_{air}V}$  with the corresponding superscripts and

$$\text{subscripts, but } \beta^{window} = \frac{A^{window}U^{window}}{C_{air}V}.$$

Such system of simultaneous equations has been studied in [9]. Without showing the details, we copy the results here: for any  $j$ th layer, denote

$$q_j = \sqrt{\frac{s}{k_j}}, \quad \xi_j = q_j l_j, \quad h_0 = \lambda_n q_n \cosh \xi_n + \alpha_- \sinh \xi_n,$$

$$h_j = \frac{\lambda_{j+1}}{\lambda_j} \sqrt{\frac{k_j}{k_{j+1}}}, \quad j = 1 \dots n-1, \quad h_n = \lambda_n q_n \sinh \xi_n + \alpha_+ \cosh \xi_n \tag{10a}$$

$$\Delta(s) = \begin{vmatrix} \lambda_1 q_1 & -\alpha_+ & 0 & 0 & \dots & \dots & \dots & \dots \\ \sinh \xi_1 & \cosh \xi_1 & 0 & -1 & \dots & \dots & \dots & \dots \\ \cosh \xi_1 & \sinh \xi_1 & -h_1 & 0 & \dots & \dots & \dots & \dots \\ \dots & \dots & \dots & \dots & \dots & \dots & \dots & \dots \\ \dots & \dots & \dots & \dots & \dots & \dots & \dots & \dots \\ \dots & \dots & \dots & \dots & \sinh \xi_{n-1} & \cosh \xi_{n-1} & 0 & -1 \\ \dots & \dots & \dots & \dots & \cosh \xi_{n-1} & \sinh \xi_{n-1} & -h_{n-1} & 0 \\ \dots & \dots & \dots & \dots & \dots & 0 & h_0 & h_n \end{vmatrix} \tag{10b}$$

$$\frac{\Delta_1(s) = -\alpha_+ \text{ same as } \Delta(s) \text{ but row } \neq 1 \text{ column } 2j-1 \text{ delete}}{\Delta(s)} \quad (10c)$$

$$\frac{\Delta_2(s) = -\alpha_- \text{ same as } \Delta(s) \text{ but row } \neq 2n \text{ column } 2j-1 \text{ delete}}{\Delta(s)} \quad (10d)$$

$$\frac{\Delta_3(s) = \alpha_+ \text{ same as } \Delta(s) \text{ but row } \neq 1 \text{ column } 2j \text{ delete}}{\Delta(s)} \quad (10e)$$

$$\frac{\Delta_4(s) = \alpha_- \text{ same as } \Delta(s) \text{ but row } \neq 2n \text{ column } 2j \text{ delete}}{\Delta(s)} \quad (10f)$$

$$M_j(s, x) = \Delta_1 \sinh(q_j(x - L_{j-1})) + \Delta_3 \cosh(q_j(x - L_{j-1})) \quad (10g)$$

$$N_j(s, x) = \Delta_2 \sinh(q_j(x - L_{j-1})) + \Delta_4 \cosh(q_j(x - L_{j-1})) \quad (10h)$$

$$\bar{G}(s) = \frac{(\eta + \sum \beta^{wall} N_1^{wall}(s, L_0) + \beta^{roof} M_1^{roof}(s, L_0) + \sum \beta^{window})}{s + \eta + \sum \beta^{wall} + \beta^{roof} + \beta^{floor} + \sum \beta^{window} - \sum \beta^{wall} M_1^{wall}(s, L_0) - \beta^{roof} M_1^{roof}(s, L_0) - \sum \beta^{floor} M_1^{floor}(s, L_0)} \quad (11a)$$

$$\bar{F}(s) = \frac{\beta^{floor} N_1^{floor}(s, L_0)}{s + \eta + \sum \beta^{wall} + \beta^{roof} + \beta^{floor} + \sum \beta^{window} - \sum \beta^{wall} M_1^{wall}(s, L_0) - \beta^{roof} M_1^{roof}(s, L_0) - \sum \beta^{floor} M_1^{floor}(s, L_0)} \quad (11b)$$

$$T_+(t) = \bar{G}(i\omega) T_- + \bar{F}(i\omega) T^{ground} \quad (12)$$

The final solution is the real part of  $T_+(t)$ ,  $Re(T_+(t))$ .

The above close-formed solution  $Re(T_+(t))$  presents the transient temperature variation indoors. It shows globally at the response of internal temperature in a building under free and real outdoor boundary condition. It is not difficult to see that the close-formed solutions for building envelope can be obtained in a similar way [9].

#### IV. VALIDATION

To assess the accuracy of the developed analytical method, the results from the analytical model will be compared to the results obtained from numerical studies. Heat transfer in one-room house is simulated. The house's dimension is  $6 \times 6 \times 2 \text{ m}^3$ .

Its envelope consists of three layers. Such envelope structure has been adopted in our test building. The main material of the wall is mineral wool (200 mm). Boundary layers consist of wall-paper (25 mm) and gypsum board (13 mm). Fig. 2 shows a schematic picture of the house and Table 1 the physical properties of its envelope.

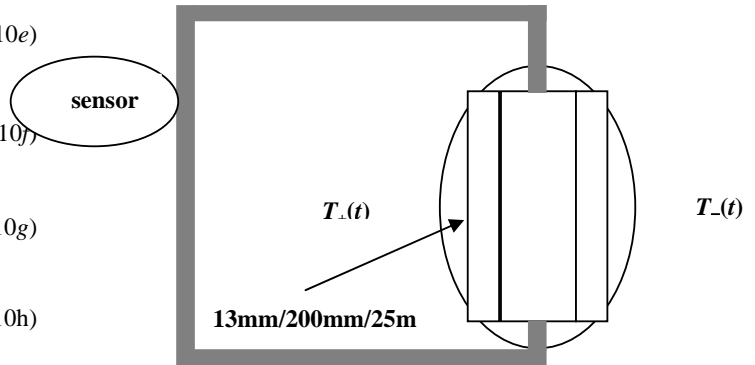

Fig. 2 Schematic diagram of the simulated house

Boundary temperature was taken from the measurement and then fitted with periodic functions with periods 30, 5, 2 and 1 days as

$$T_-(t) = a_0 + \sum_{i=1}^4 a_i \cos\left(\frac{2\pi}{\omega_i}(t - \varphi_i)\right) \quad (13)$$

where fitting parameters are listed in Table 2. The convective and radiative heat transfer coefficients are  $\alpha_c = 25 \text{ W/m}^2/\text{K}$  and  $\alpha_r = 6 \text{ W/m}^2/\text{K}$ .

The calculated transient indoor temperatures by analytical and numerical models are displayed in Fig. 3. The maximal discrepancy is about  $0.9^\circ\text{C}$  (relative error about 6%). Agreement between numerical and analytical results is good. The validation of the numerical program can be found in [10].

TABLE 1  
MATERIAL PROPERTIES AND DIMENSIONS FOR THE ENVELOPE OF THE SIMULATED HOUSE

	Thermal conductivity (W/m/K)	Thermal diffusivity ( $\text{m}^2/\text{s}$ )	Thickness (mm)
gypsum board	0.23	$4.1 \times 10^{-7}$	13
mineral wool	0.147	$1.5 \times 10^{-6}$	200
paper	0.12	$1.5 \times 10^{-7}$	25

#### V. CONCLUSION

An analytical model was developed in this paper which gives close-formed solutions for both transient indoor temperature and construction temperatures in a building

system. No restriction on the layer number and the thermal physical properties of the construction was needed. The method is free of numerical program. In general literature works for such problem, however, there usually exists limitation on layer number of the construction, or associated numerical iteration is often necessitated. Additionally, mathematical expression for closed-formed solutions is simple and concise with good accuracy. The model can be used to analyse the thermal process in relation to physical parameters.

TABLE II  
PARAMETERS IN EQUATION (13)

$\omega_1$	$\omega_2$	$\omega_3$	$\omega_4$
30.0	5.0	2.0	1.0
$\varphi_1$	$\varphi_2$	$\varphi_3$	$\varphi_4$
5.607506	13.59596	1.451539	5.418717
$a_0$	$a_1$	$a_2$	$a_3$
5.0	2.72217	-5.019664	1.084058
			$a_4$
			0.4648

#### ACKNOWLEDGMENT

This research was supported by the Academy of Finland.

#### REFERENCES

- [1] X. Lu, D. Clements-Croome and M. Viljanen, "Past, present and future mathematical models for buildings: focus on intelligent buildings (I)", *Intelligent Building International Journal*, vol 1, pp23-38, 2009.
- [2] H.S. Carslaw and J.C. Jaeger, *Conduction of Heat in Solid* (2<sup>nd</sup> ed.), Oxford University Press: Oxford, UK, 1959.
- [3] M.D. Mikhailov and M.N. Özisik, *Unified Analysis and Solutions of Heat and Mass Diffusion*, Dover Publications Inc.: Mineola, N.Y., 1994.
- [4] T.P. Fredman, "An analytical solution method for composite layer diffusion problem with an application in metallurgy", *Heat and Mass Transfer*, vol. 39, pp. 285-295, 2003.
- [5] G.P. Mitalas, "Calculation of transient heat flow through walls and roofs", *ASHRAE Transactions*, vol. 74, pp. 182-188, 1968.
- [6] D.G. Stephenson and G.P. Mitalas, "Calculation of heat conduction transfer functions for multilayer slabs", *ASHRAE Transaction*, vol. 77, pp. 117-126, 1971.
- [7] M.S. Bhandari and N. Bansal, "Solar heat gain factors and heat loss coefficients for passive heating concepts", *Solar Energy*, vol. 53, pp. 199-208, 1994.
- [8] J. Boland, "The analytical solution of the differential equations describing heat flow in houses", *Building and Environment*, vol. 37, pp. 1027-1035, 2002.
- [9] X. Lu, T. Lu and M. Viljanen, "A new analytical method to simulate heat transfer process in buildings", *Applied Thermal Engineering*, vol. 26, pp. 1901-1909, 2006.
- [10] X. Lu, "Modelling heat and moisture transfer in buildings: (I) Model program", *Energy and Buildings*, vol. 34, pp. 1033-1043, 2002.

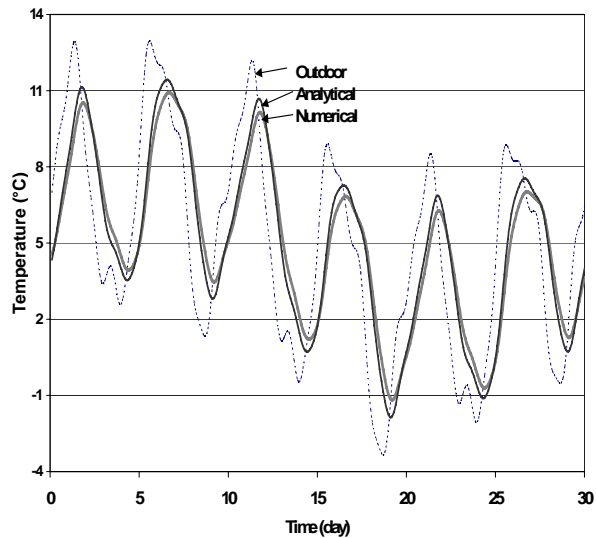

Fig. 3 Comparison of numerical and analytical results