

Non-Isolated Direct AC-DC Converter Design with BCM-PFC Circuit

Y. Kobori, L. Xing, H. Gao, N. Onozawa, S. Wu, S. N. Mohyar, Z. Nosker, H. Kobayashi, N. Takai and K. Niitsu

Abstract—This paper proposes two types of non-isolated direct AC-DC converters. First, it shows a buck-boost converter with an H-bridge, which requires few components (three switches, two diodes, one inductor and one capacitor) to convert AC input to DC output directly. This circuit can handle a wide range of output voltage. Second, a direct AC-DC buck converter is proposed for lower output voltage applications. This circuit is analyzed with output voltage of 12V. We describe circuit topologies, operation principles and simulation results for both circuits.

Keywords—AC-DC converter, Buck-boost converter, Buck converter, PFC, BCM PFC circuit.

I. INTRODUCTION

AC-DC converters are indispensable for virtually all electronic devices, from cell phones to large manufacturing machinery. AC-DC converters produce steady direct current (DC) from alternating current (AC) inputs. In a typical converter, the AC input is rectified and connected to a high voltage, high frequency switching circuit employing a transformer to create the desired DC output voltage. However, this type of converter is bulky and has low efficiency, because it contains a DC-DC converter, a transformer, and a rectifier.

We have proposed a circuit to realize non-isolated direct AC-DC conversion: a non-inverting buck-boost converter with H-bridge circuit [1]. This circuit comprises of three switches operated by changes in input voltage polarity to make current flow in the inductor in one direction. In this circuit, the output voltage can be set to a value above the input voltage to a value less than 10 volts. Next we propose a novel direct AC-DC buck converter for low output voltage with a single switch and one diode bridge.

In this paper, we introduce their operating principles and show simulation results to verify their basic operation and performance. We also calculate the voltage-conversion ratio and compare it with that of a commonly used buck-boost converter.

II. DIRECT BUCK-BOOST AC-DC CONVERTER

A. Proposed Circuit and Operation

The proposed direct buck-boost AC-DC converter is shown in Fig.1 and Fig.2, where the red solid line shows current flow

Y. Kobori is an adjunct professor at Gunma University, Kiryu, Japan and he is also with Oyama National College of Technology, Oyama, Japan (phone: +81-285-20-2255; fax: 285-20-2886, e-mail: kobori@oyama-ct.ac.jp).

L. Xing, G. Hong, N. Onozawa, S. Wu, S.H. Mohyar, Z. Nosker, H. Kobayashi, N. Takai and K. Niitsu are with Department of Electronic Engineering, Gunma University, Kiryu, Japan (e-mail: k_haruo@el.gunma-u.ac.jp).

when the inductor is charged, and the blue dashed line shows the current flow when the inductor is discharged. Three switches operate at a frequency of 200 kHz and the operation mode varies with changes in input voltage polarity and the charging or discharging of the inductor.

Let us consider the case when the input voltage is positive, as shown in Fig.1 and Fig.3 (a). First, S1 and S3 are ON for a time of $D \cdot T_s$ (D is the duty ratio, the ON part of the duty cycle, and T_s represents the switching period) and the inductor is charged. Next S1 and S3 are turned OFF and D1 and D2 are turned ON so that the inductor is discharged into the capacitor and the resistor. For a positive input, S1 and S3 are alternately turned ON and OFF as shown in Fig.3 (a). The operation is just like the common buck-boost converter, and we obtain a steady output voltage.

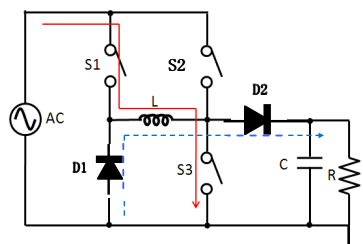

Fig. 1 H-Bridge AC-DC converter (Current when $V_{in} > 0$)

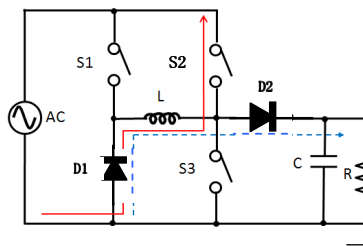

Fig. 2 H-Bridge AC-DC converter (Current when $V_{in} < 0$)

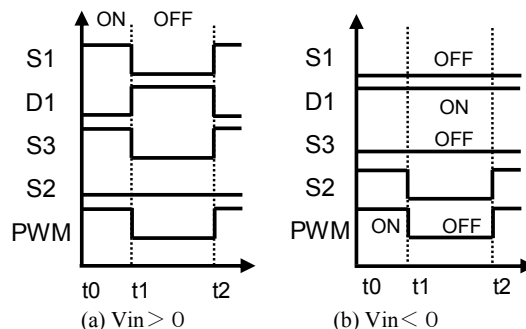

Fig. 3 Timing chart of switches

B. Simulation Results

The circuit schematic for simulation is illustrated in Fig.4. The input voltage is 100Vrms with a frequency of 50 Hz and we use PWM operating at 200 kHz. The other parameters are shown in Table I. We set the output voltage to 50V and the output current to $I_o=0.5A$.

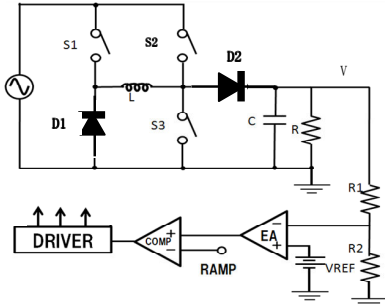

Fig. 4 Simulation circuit

TABLE I
SIMULATION PARAMETERS OF FIG. 4

C	220 uF
L	220 uH
V_o	50 V
I_o	0.5 A
VREF	5.0 V

The waveforms of input voltage V_i and output voltage, output voltage ripple, the inductor current waveform and load transient response are shown in Fig.5, Fig.6, Fig.7 and Fig.8 respectively. These figures show the transient responses when the input voltage is near its peak value. The output voltage ripple is 6mVpp, which is very small, and the inductor current ripple is under 1.7A.

For the transient response, we set the current change just as $\Delta I = 1.0 \times 0.5A$. The voltage ripple is 15mVpp / 0.5A in Fig.7, which is very small compared with the output voltage. We see in Fig.8 that when the inductor current is large (1.0A), it operates in continuous mode. When the inductor current is small (0.5A), it operates in intermittent mode.

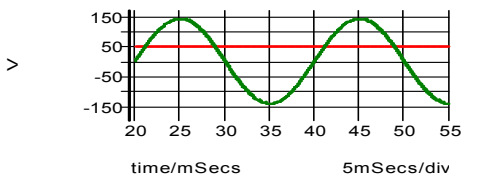

Fig. 5 Waveform of input voltage and output voltage

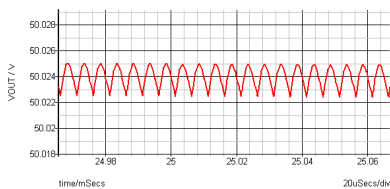

Fig. 6 Output voltage ripple

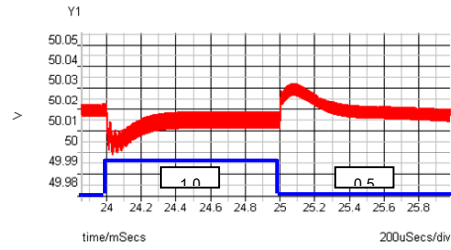

Fig. 7 Load transient response

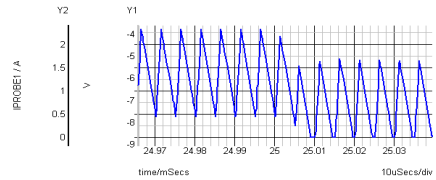

Fig. 8 Waveform of inductor current

C. Voltage Conversion Ratio

Compared with the PWM clock frequency, the frequency of the input sine wave is very low; hence the instantaneous input voltage can be considered to be almost constant. Accordingly, the output voltage V_o can be calculated as follows [2]:

$$V_o = \frac{D}{1-D} \cdot V_i$$

$$= \sqrt{2} \frac{D}{1-D} \cdot V_{rms} \cdot \sin(\theta) \tag{1}$$

$$D(\theta) = \frac{1}{1 + \sqrt{2} / M \cdot \sin(\theta)} \tag{2}$$

Here D is the duty ratio, and M is given by

$$M = V_o / V_{rms} \tag{3}$$

Thus the average duty ratio D^* in a half period is obtained as follows:

$$D^* = \frac{1}{\pi} \int_0^\pi D(\theta) d\theta$$

$$= \frac{1}{\pi} \int_0^\pi \frac{d\theta}{1 + \sqrt{2} / M \cdot \sin(\theta)} \tag{4}$$

Since we cannot solve the above equation analytically, we solved it approximately by using interval integration. In Fig.9 we compare the result with that of a commonly used non-inverting buck-boost converter, where the lateral axis indicates the average duty ratio and the vertical axis shows the output voltage. We see that, compared with the common buck-boost converter, the output voltage is a little bit smaller for the same duty ratio; in other words a larger duty ratio is used for a given low output voltage, which makes it possible for our circuit to convert to a low output voltage directly, and this is an advantage over the commonly-used PWM-controlled buck-boost converter.

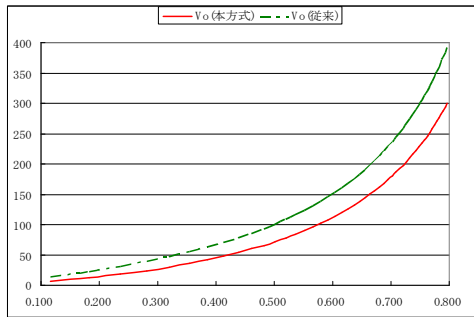

Fig. 9 Average duty ratio vs. V_o (V_i rms=100V)

III. DIRECT BUCK AC-DC CONVERTER

A. Proposed Circuit and Operation

The proposed direct buck AC-DC converter with a diode bridge is shown in Fig.10, where the output DC voltage V_o is less than the input AC voltage V_i rms. The input AC source is first rectified by the diode bridge, where the red solid line shows current flow when the inductor is charged, and the blue dashed line shows the current flow when the inductor is discharged. The switch S operates at a frequency of 200 kHz and the current mode in the diodes varies with changes in input voltage polarity and the charging or discharging of the inductor.

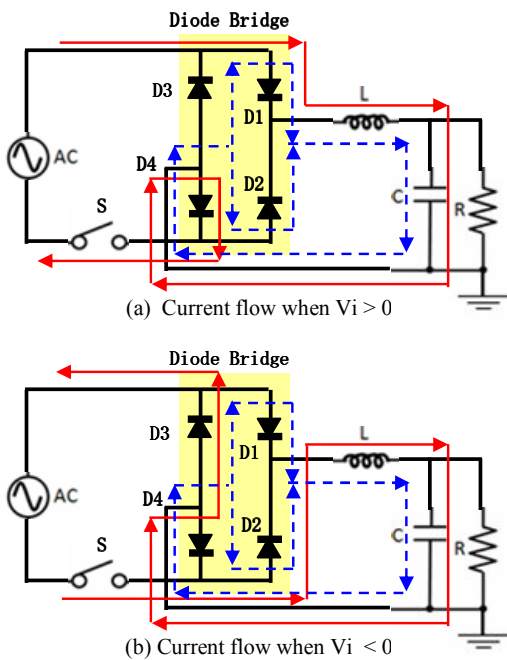

Fig. 10 Direct Buck AC-DC converter

The operation of the switch is as follows: (1) When $V_i > 0$, first the switch is ON and the current flows through D1 and D4. Next the switch is OFF which causes the current to flow through D3-D1 or D4-D2 as in Fig. 10(a); (2) When $V_i < 0$, first the switch is ON and the current flows through D2-D3. When the switch is OFF, the current flows same as $V_i > 0$ as shown in Fig. 10(b).

B. Simulation Results

We have performed circuit simulations to check the operation and performance of the proposed direct buck AC-DC converter.

The waveforms of input voltage, output voltage and output voltage ripple for a load current of 0.5 A are shown in Fig.11 and Fig.12. We see that output offset is +10mV and output ripples are +65/-95 mV, which occur at zero-cross points of the input source.

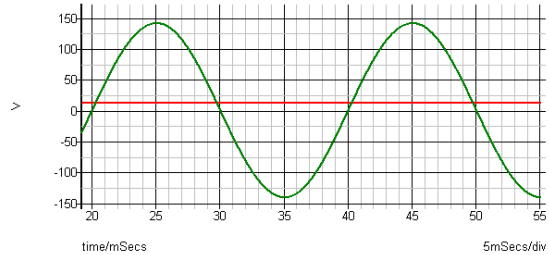

Fig. 11 Output voltage of inverting converter

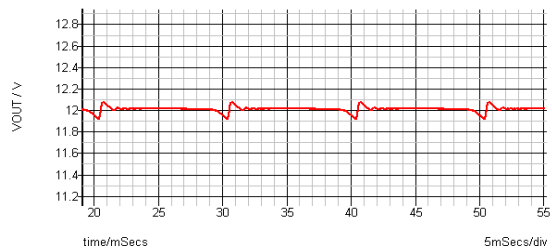

Fig. 12 Output ripple of the inverting converter

For the transient response, we set the current change just as $\Delta I = 1.0 \times 0.5A$. The voltage ripple is $\pm 7mV_{op} / 0.5A$ in Fig. 13, which is very small compared with the output voltage.

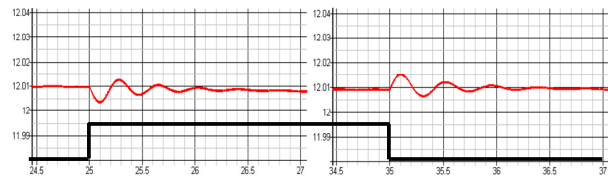

Fig. 13 Load transient response

IV. POWER FACTOR CORRECTION (PFC) CIRCUIT

For AC-DC converters, distortion of the input current and spurious current at clock frequencies should be reduced below the level permitted by EMI (Electro-Magnetic Interference) regulations, because AC-DC converters are connected directly to the power lines. We have designed PFC circuits to meet this requirement.

A. Conventional PFC in Boost Converter

In conventional AC-DC converters, a boost-type PFC circuit with an active filter is frequently used as shown in Fig. 14. It consists of an analog multiplier, an op-amp, two comparators and D, L, C components. In this circuit, the on-time of the PWM signal should be constant to keep the waveform of the

input current similar to that of the input voltage sine wave. The waveform of the inductor current, as shown in Fig.15, is a series of triangle waveforms in BCM. The current is zero at switching timing from off to on. The solid line represents the charge current to the inductor and the dashed line shows the discharge. So the input charges in a single triangle waveform and the voltage source is shown below.

$$Q_{in}(t) = T * (T_{on} * V_i * \sin \omega t) / 2L \tag{5}$$

The on-time T_{on} of PWM signal is designed to be constant but the off-time is variable, and thus the clock frequency varies in phase. In this case, the PWM period is given below,
 $T = T_{on} + T_{off}$

$$= T_{on} + L * T_{on} * V_i * \sin \theta / (V_o - T_{on} * V_i * \sin \theta) \tag{6}$$

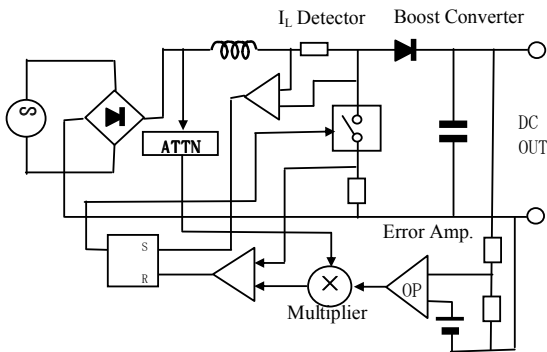

Fig. 14 Conventional PFC circuit in BCM

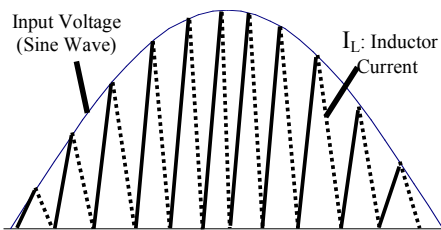

Fig. 15 Waveform of inductor current in BCM

B. New PFC in Buck Converter

Since our proposed circuit is a buck-boost converter different from the above boost converter, it needs a new PFC circuit. In our proposed circuit, the input current is not equal to the inductor current, because the on-time current is input current and the off-time current is load current. Thus the on-time is constant and the off-time is given by

$$I_{off}(t) = I_p - t * V_o / L \tag{7}$$

$$= T_{on} * V_i * \sin(\theta i) / L - t * V_o / L$$

$$\therefore T_{off} = (V_i / V_o) * T_{on} * \sin(\theta i) \tag{8}$$

Here, I_p represents the peak current of I_L .

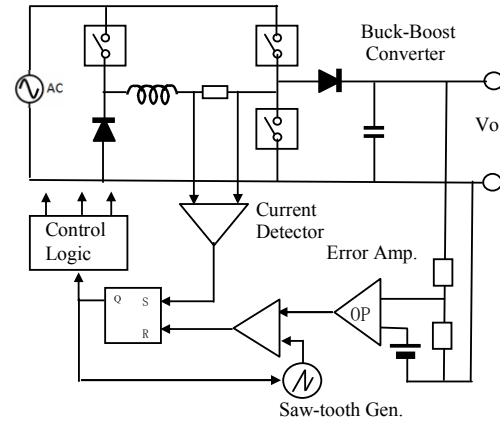

Fig. 16 New BCM PFC without an analog multiplier

Equation (8) tells us that T_{off} is proportional to the input $\sin(\theta i)$ wave. Thus the input current is shaped nearly the same as the input voltage because the average of V_i/V_o is much larger than 1 in “(8)”. This means that a multiplier is not needed in the new PFC system shown in Fig.16. We note that conventional AC-DC PFC correction requires large capacitors to hold the input AC power and to output the DC power, and our proposed converter also requires a large capacitor of 47mF.

C. Simulation Results

In general, AC-DC converters have many output voltages and today’s most popular level is 12V output. Fig.17 shows the input voltage and the output voltage as well as the input current. The input current is of saw-tooth shape with clock frequency of about 100 kHz. In Fig.17, the input current represents the waveform of the source current through a LPF.

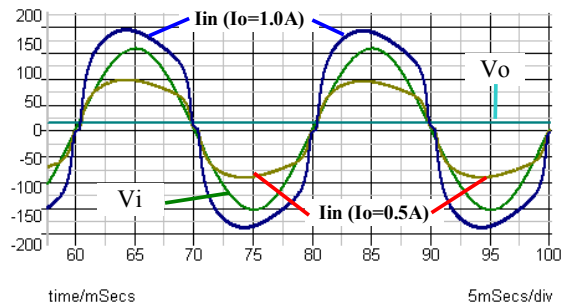

Fig. 17 Waveform of V_i , V_o and I_{in} (through LPF)

In this waveform, the power factor calculated from simulation is about 0.97. The output voltage ripple caused by clock signals is small enough, and ripple caused by input signals is 25mVpp at $I_o=0.5A$. and 60mVpp at $I_o=1.0A$. The ripple frequency is 100Hz. Fig.19 shows the waveform of the input voltage and the inductor current while Fig.20 shows the wide scope waveform of the inductor current.

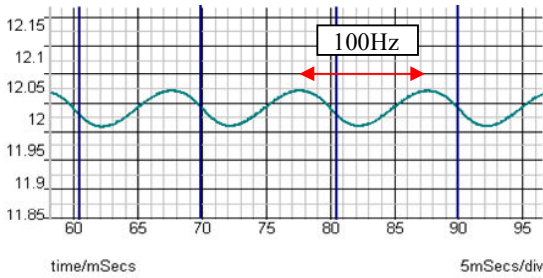

Fig. 18 Output voltage ripple ($I_o=1.0$ A).

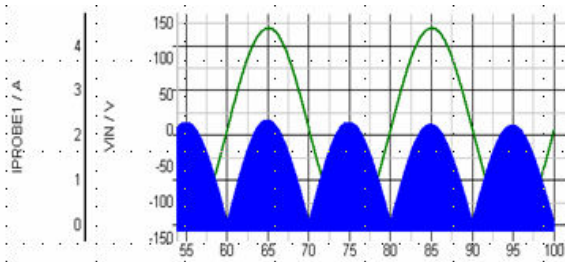

Fig. 19 Input voltage and inductor current.

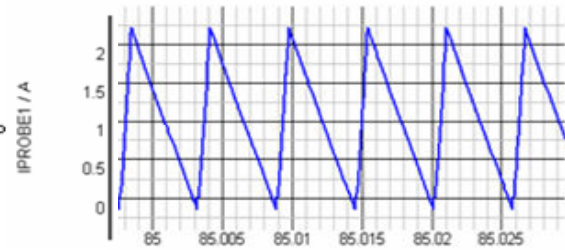

Fig. 20 Inductor current in BCM

Fig. 21 shows the characteristics of load regulation: the ripple and the offset of the output voltage at $V_i=100$ Vrms and $V_o=12$ V when the output current is changed. In this case, the output voltage ripple and the output offset is linear to the output current I_o . Fig. 22 shows the characteristics of line regulation: the ripple and the offset of the output voltage at $I_o=1.0$ A and $V_o=12$ V when the input voltage is changed. The ripple is almost constant and the offset increases exponentially with load current.

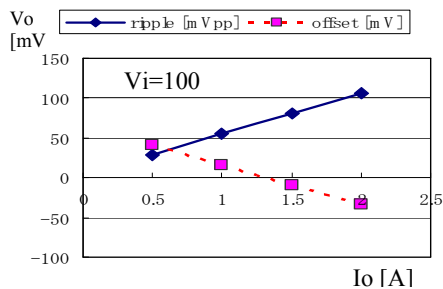

Fig. 21 Output ripple and offset vs. output current

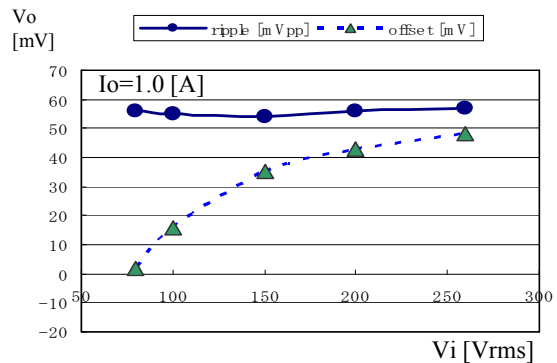

Fig. 22 Output ripple and offset vs. input voltage

V. CONCLUSION

In this paper, we have described a direct AC-DC buck-boost converter with H-bridge topology, a direct AC-DC buck converter and a PFC circuit in BCM for a direct AC-DC buck converter. We have investigated and proposed direct AC-DC buck converters and those with BCM-PFC circuit. We explained their principles of operation and verified their basic operation by simulations. Simulation results show that the output voltage ripple for buck converters ($V_o=12$ V) with direct BCM-PFC circuit is 60mVpp at $I_o=1.0$ A. Furthermore we have developed a new PFC circuit for BCM converters with a new multiplexer. Our simulations show that the power factor in BCM-PFC circuit is about 0.97 at $V_i=100$ Vrms, $V_o=12$ V and $I_o=1.0$ A.

ACKNOWLEDGMENT

Authors would like to thank T. Shishime, M. Ohshima and, N. Okamoto for valuable discussions.

REFERENCES

- [1] L. Xing, H. Gao, Y. Kobori, N. Okamoto, M. Ohshima, K. Wakabayashi, T. Okada, M. Onozawa, H. Kobayashi, N. Takai and K. Niitsu , "Novel DC-DC Converter Design," IEE Japan, Papers of Technical Meeting on Electronic Circuits, ECT-11-047, July 2011, pp. 59-64 (Japanese)
- [2] K. Harada, T. Ninomiya and B. Ko, *Fundamentals of Switched-Mode Converters*, Corona Publishing Co., LTD. (2004)