

BEM Formulations Based on Kirchhoff's Hypothesis to Perform Linear Bending Analysis of Plates Reinforced by Beams

Gabriela R. Fernandes, Renato F. Denadai, and Guido J. Denipotti

Abstract—In this work, are discussed two formulations of the boundary element method - BEM to perform linear bending analysis of plates reinforced by beams. Both formulations are based on the Kirchhoff's hypothesis and they are obtained from the reciprocity theorem applied to zoned plates, where each sub-region defines a beam or a slab. In the first model the problem values are defined along the interfaces and the external boundary. Then, in order to reduce the number of degrees of freedom kinematics hypothesis are assumed along the beam cross section, leading to a second formulation where the collocation points are defined along the beam skeleton, instead of being placed on interfaces. On these formulations no approximation of the generalized forces along the interface is required. Moreover, compatibility and equilibrium conditions along the interface are automatically imposed by the integral equation. Thus, these formulations require less approximation and the total number of the degrees of freedom is reduced. In the numerical examples are discussed the differences between these two BEM formulations, comparing as well the results to a well-known finite element code.

Keywords—Boundary elements, Building floor structures, Plate bending.

I. INTRODUCTION

THE boundary element method (BEM) has already proved to be a suitable numerical tool to deal with plate bending problems. The method is particularly recommended to evaluate internal force concentrations due to loads distributed over small regions that very often appear in practical problems. Moreover, the same order of errors is expected when computing deflections, slopes, moments and shear forces. Shear forces, for instance, are much better evaluated when compared with other numerical methods. They are not obtained by differentiating approximation function as for other numerical techniques.

Using BEM coupled with the finite element method (FEM) is the natural numerical procedure to analyze plate reinforced by beams, where the BEM is used to represent the plate

elements and the FEM to approximate the beam elements. Regarding this numerical technique several formulations have already been proposed ([1]-[4]), where the BEM formulation is based either on Kirchhoff's or Reissner's hypothesis. However, for complex floor structures the number of degrees of freedom may increase rapidly diminishing the solution accuracy.

Recently Fernandes and Venturini [5] proposed two formulations based only on the BEM to perform bending analysis of plates reinforced by beams. In the present work are shown new applications of these two BEM formulations, comparing the results to a well-known finite element code. The formulations are based on Kirchhoff's hypothesis, being the building floor modelled by a zoned plate where each sub-region represents a beam or a slab. This composed structure is treated as a single body, being the equilibrium and compatibility conditions automatically taken into account. The tractions were eliminated along the interfaces, reducing therefore the number of degrees of freedom. In the first model the values are defined along the interfaces and on the external boundary. Then in order to reduce further the number of degrees of freedom some approximations for the displacements were made along the beam width, leading to the second model where the values are defined along the beams skeleton lines and on the external boundaries without beams.

II. BASIC EQUATIONS

Without loss of generality, let us consider the three sub-region plate depicted in Fig. 1, where t_1 , t_2 and t_3 are the sub-regions thicknesses. The sub-regions are referred to a Cartesian system of co-ordinates with axes x_1 , x_2 and x_3 defined in their middle plane. The plate sub-domains assumed as isolated plates are denoted by Ω_1 , Ω_2 and Ω_3 , with boundaries Γ_1 , Γ_2 and Γ_3 , respectively. Alternatively, when the whole solid is considered, Γ gives the total external boundary, while Γ_{jk} represents interfaces, for which the subscripts denote the adjacent sub-regions (see Fig. 1).

Manuscript received March 20, 2007. This work was supported by FAPESP (São Paulo State Foundation for Scientific Research).

All authors are with the Civil Engineering Department of São Paulo State University – UNESP, Al. Bahia, 550, 15385-000 Ilha Solteira, Brazil.

G. R. Fernandes: e-mail: gabrielarf@stetnet.com.br.

Renato F. Denadai: e-mail: renatotampa@yahoo.com.br.

Guido J. Denipotti: e-mail: guidodenipotti@bol.com.br.

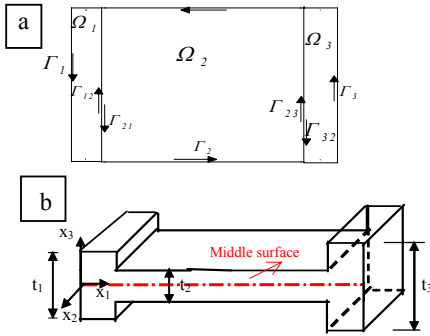

Fig. 1 a) Middle surface view a) General zoned plate domain

For this plate, considering the Kirchhoff's hypothesis (see [6]-[9]), the following basic relationships are defined:

- Equilibrium equations in terms of internal forces:

$$m_{ij,j} - q_i = 0 \quad (1)$$

$$q_{i,i} + g = 0 \quad (2)$$

where g is the distributed load acting on the plate middle surface, m_{ij} are bending and twisting moments, while q_i represents shear forces, with subscripts taken in the range $i,j = \{1, 2\}$.

- The plate bending differential equation,

$$m_{ij,ij} + g = 0 \quad (3)$$

or

$$w_{,ijij} = \frac{g}{D} \quad (i, j = 1, 2) \quad (4)$$

where $D = Eh^3 / (1 - \nu^2)$ is the flexural rigidity and $w_{,ijij} = \nabla^2 w$, is the Laplacian operator.

- The generalised internal force \times displacement relations,

$$m_{ij} = -D(\nu \delta_{ij} w_{,kk} + (1 - \nu) w_{,ij}) \quad (5)$$

$$q_i = -D w_{,jji} \quad (6)$$

- The effective shear force,

$$V_n = q_n + \partial m_{ns} / \partial s \quad (7)$$

where (n, s) are the local co-ordinate system, with n and s referred to the boundary normal and tangential directions, respectively; no summation is implied.

The problem definition is then completed by assuming the following boundary conditions over Γ : $u_i = \bar{u}_i$ on Γ_1 (generalised displacements, deflections and rotations) and $p_i = \bar{p}_i$ on Γ_2 (generalised tractions, normal bending moment and effective shear forces), where $\Gamma_1 \cup \Gamma_2 = \Gamma$.

III. INTEGRAL REPRESENTATIONS

Both formulations are obtained from Betti's reciprocal theorem which for a particular sub-region Ω_m can be written in terms of efforts as follow:

$$\int_{\Omega_m} w_{,jk}^{m*} m_{jk}^m d\Omega = \int_{\Omega_m} m_{jk}^{m*} w_{,jk}^m d\Omega \quad (8)$$

where no summation is implied on m .

For convenience the fundamental value of curvature will be written in terms of the one related to the sub-region where is placed the source point q .

$$w_{,jk}^{m*} = [D / D_m] w_{,jk}^* \quad (9)$$

where D_m is related to sub-region Ω_m ; the value D refers to the sub-region where q is placed.

Considering (9) and applying (8) for all sub-regions, one obtains the bending reciprocity relations for the whole plate (see [5]), which can be integrated by parts to give the following integral representations of deflection:

$$\begin{aligned} K(q)w(q) = & - \sum_{m=1}^{N_{Sub}} \frac{D_m}{D} \int_{\Gamma_m} \left(V_n^* w - M_n^* \frac{\partial w}{\partial n} \right) d\Gamma - \sum_{j=1}^{N_{c1}} \frac{D_j}{D} R_{cj}^* w_{cj} \\ & - \sum_{j=1}^{N_{c2}+N_{c3}} \left(\frac{D_j - D_a}{D} \right) R_{cj}^* w_{cj} - \sum_{j=1}^{N_{int}} \int_{\Gamma_{ba}} \left(\frac{D_b - D_a}{D} \right) \left(V_n^* w - M_n^* \frac{\partial w}{\partial n} \right) d\Gamma \\ & + \sum_{j=1}^{N_{c1}} R_{cj} w_{cj}^* + \int_{\Gamma} \left(V_n w^* - M_n \frac{\partial w^*}{\partial n} \right) d\Gamma + \int_{\Omega_g} g w^* d\Omega \quad (10) \end{aligned}$$

where the subscripts b and a refers, respectively, to the beam sub-region and its adjacent sub-region, N_{int} is the number of interfaces; n and s are the local normal and shear direction coordinates; c_1 , c_2 and c_3 are different kinds of corners (for their definitions and their corresponding free term values see Fernandes and Venturini [5]); Ω_g is the plate loaded area; $K(q)=1$, $K(Q)=0.5$ and $K(Q)=0.5(1+D_a/D)$, respectively, for internal, boundary and interface points.

Equation (10) corresponds to the first model, being defined four values on the boundary: w , $w_{,n}$; M_n and V_n and two displacements: w and $w_{,n}$ along interfaces. So that, to obtain the problem solution the nodes must be defined along the interfaces and all external boundaries. Note that the tractions were eliminated on the interfaces.

In order to obtain the second model, let us now consider the beam B_3 represented in Fig. 2a by the sub-region Ω_3 . In order to reduce the number of degrees of freedom, some Kinematic hypothesis will be assumed along the beams cross sections, where we have adopted constant approximation for the rotation and linear for the deflection (see Fig. 2b). Thus the interface displacement vector related to the beam interfaces are translated to the skeleton line, as follows:

$$w^{r32} = w + w_{,n} b_3 / 2 \quad (11a)$$

$$w^{r31} = w - w_{,n} b_3 / 2 \quad (11b)$$

where b_3 is the beam width, $u_k^{f_{ij}}$ and $w^{f_{ij}}$ are displacement components along the interface Γ_{31} and Γ_{32} ; u_k , w , $u_{k,n}$ and $w_{,n}$ are components along the skeleton line.

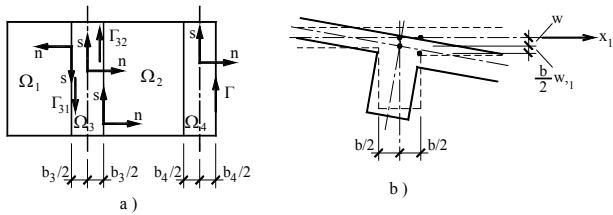

Fig. 2 a) Reinforced plate view; b) Deflection approximations along interfaces

Replacing (11) into (10), the problem values are defined along the beam axis, instead of its boundary. So the required number of nodes necessary to solve the problem is strongly reduced. Note that the integrals are still performed on the interfaces. As the collocation points are defined on the skeleton line, there is no problem of singularities. Observe that the integral representation of $w_{,n}$ is easily obtained by differentiating (10).

IV. ALGEBRAIC EQUATIONS

As usual, for any BEM formulation, the integral representation (10) and the ones written to compute internal forces can be transformed into algebraic expressions after discretizing the boundary and interfaces into elements. For the present case, one has adopted linear elements over which the boundary values have been approximated by quadratic shape functions.

For the first model, the set of equations is obtained by writing two deflection equations (10) for each boundary node (one at an external collocation point very near to the boundary and another one at a point placed on the boundary) plus one deflection equation and one slope equation written at interfaces nodes. For the second model we write two deflection equations on the external boundary without beams plus one deflection and one slope equation at nodes on the skeleton line. Note that an extra relation of deflection at each corner is also required for both models. After performing the element integrals, the algebraic set of equations reads:

$$HU = GP + T \tag{12}$$

where \mathbf{U} contains deflection and rotation nodal values, while \mathbf{P} contains boundary node tractions; \mathbf{T} is the independent vector due to the applied loads.

V. NUMERICAL APPLICATIONS

For both examples presented in this section the results have been compared with a well-known finite element code (ANSYS, version 9). It is important to stress that the structural system modelled by BEM and FEM are not exactly the same

and therefore the results can be only similar. For the FEM analysis finite shell elements have been used to discretize all floor slabs as well as the beams. Using BEM we have treated the whole body as a solid, therefore without splitting the plate and the beams; beams are inclusions in the whole body.

In what follows (BEM - IN) refers to the first model where the nodes are defined on the interfaces; (BEM - BAN) refers to the second model where the nodes are defined on the beam axis and (FEM) is related to the ANSYS analysis for simple bending case. For both BEM models were considered two discretizations to confirm the results convergence.

Note that because of the approximations assumed for the displacements along the beams cross sections, the model (BEM - BA) is more rigid than (BEM - I), that is why we expect smaller displacements for (BEM - BA). Observe also that for the model (BEM - BA) the elements defined at beam extremities and coincident to the beam width are automatically generated by the code, so that there is no need of defining them.

A. Simple Stiffened Plate

In this first example it will be considered the stiffened plate depicted in Fig. 3, where three sides are free ($V_n=M_n=0.0$) while the other one is fixed ($w=w_{,n}=0.0$) (see Fig. 3b).

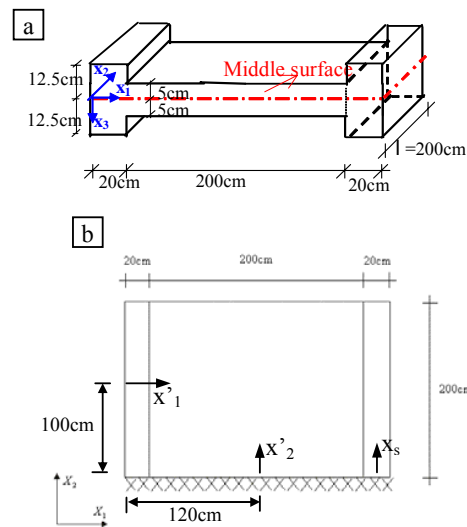

Fig. 3 a) Stiffened Plate view, b) plate middle surface

A distributed load of $0.4kN/cm^2$ is applied on the whole surface of the structure. Young's modulus $E=27000kN/cm^2$ and Poisson's ratio $\nu=0.2$ were adopted. The results for displacements and moments will be computed along the local axis x'_1 , x'_2 and x_3 defined in Fig. 3b.

The poorest discretization adopted for the model (BEM - I) had 114 nodes and 52 elements (8 elements on each interface, 1 element along the boundary that defines the beam width and 8 elements along the remaining boundary sides), as shown in Fig. 4; the finer mesh had 100 elements giving the total amount of 210 nodes. Considering the model (BEM - BA), for the poorest mesh one has defined 48 elements (12 elements on each beam axis plus 12 elements on the boundary

not coincident to the beam width) requiring 100 nodes (see Fig. 4b); 196 nodes and 96 elements have been considered for the finer discretization. Note that despite the discretizations adopted for the model (BEM – I) have almost the same number of elements of the corresponding one adopted for the model (BEM – BA), the last ones are much finer.

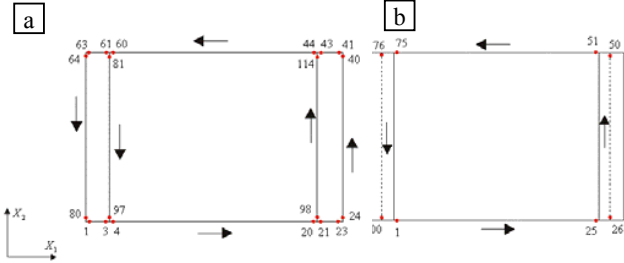

Fig. 4 Boundary Discretizations a) Model (BEM – I) b) Model (BEM – BA)

Note that as the lines with displacements prescribed are coincident for both BEM models, we expect bigger differences in the numerical results only in the x_1 direction because of the approximations assumed for the displacements along the beam width, in the model (BEM – BA).

It is interesting to point out that except for the moments computed along the x'_1 axis considering the model (BEM – I) (see Fig. 5), there was no significant difference between the results obtained with the poorer and the finer meshes.

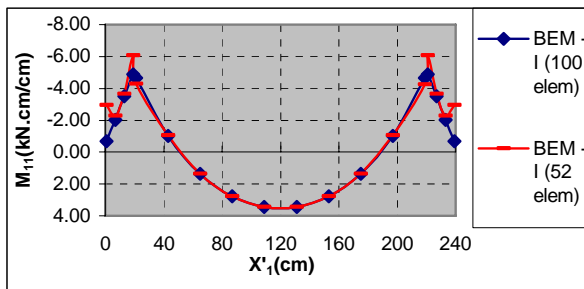

Fig. 5 Moment (M_{11}) in the plate, along x'_1 axis

Figs. 6 and 7 show, respectively, the deflection and the moment with respect to direction x_2 along x'_2 axis defined in the plate (see Fig. 3b).

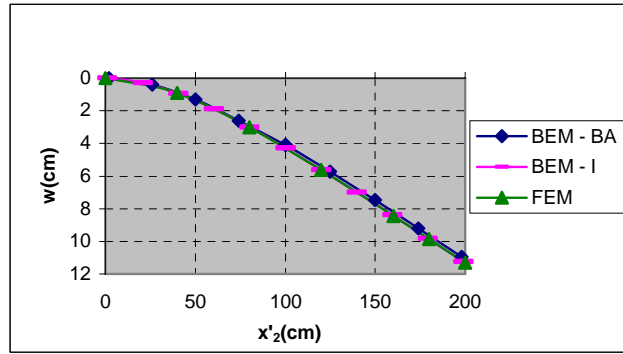

Fig. 6 Deflection in the plate, along x'_2 axis

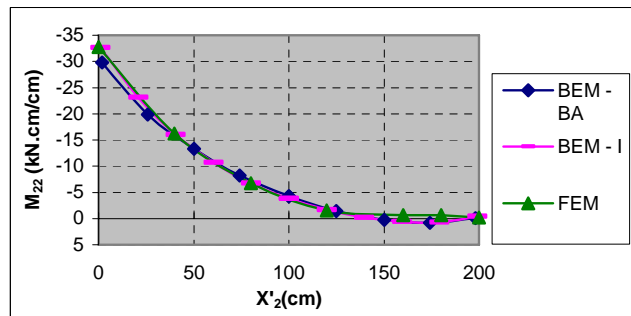

Fig. 7 Moment (M_{22}) in the plate, along x'_2 axis

The displacements and moments with respect to direction x_2 along the X_s axis defined in the beam (see Fig. 3b) are displayed in Figs. 8 and 9.

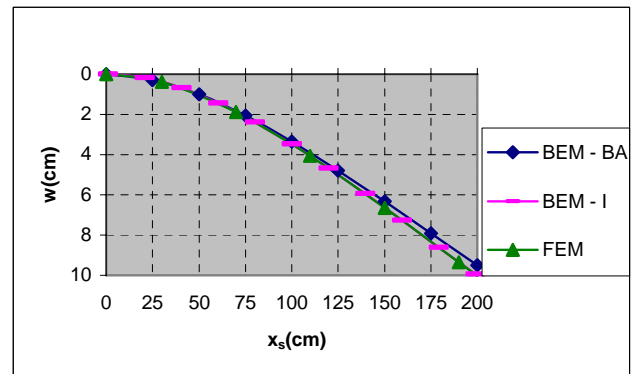

Fig. 8 Deflection along the beam axis

Figs. 10 and 11 show, respectively, the deflection and the moment with respect to direction x_1 along x'_1 axis defined in the plate (see Fig. 3b).

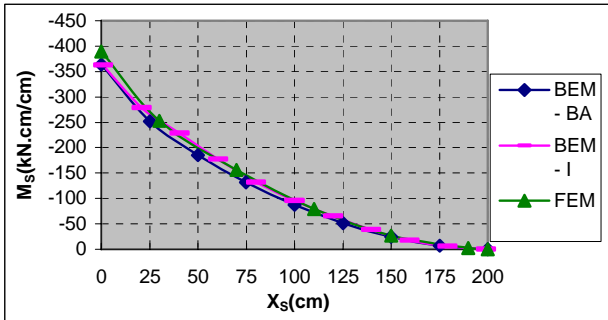

Fig. 9 Moment (M_{22}) along the beam axis

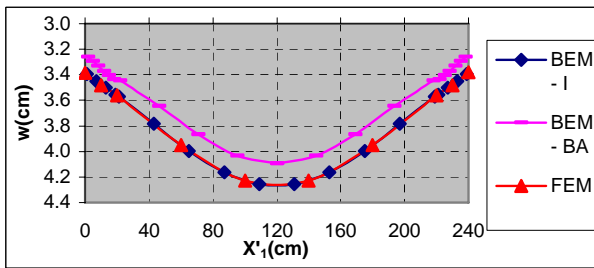

Fig. 10 Deflection in the plate, along x'_1 axis

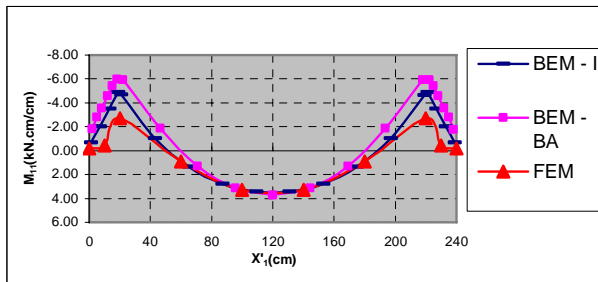

Fig. 11 Moment (M_{11}) in the plate, along x'_1 axis

B. Reinforced Building Floor

This example deals with a more complex building floor structure, defined by five beams and two plate regions as shown in Fig. 12.

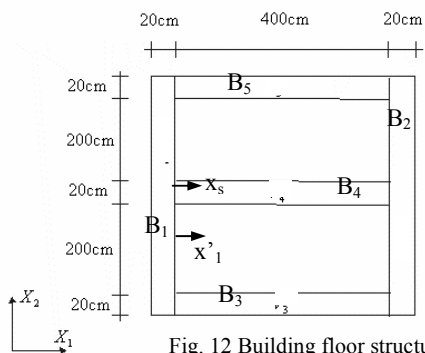

Fig. 12 Building floor structure

The plate thickness is equal to $h_p = 8.0\text{cm}$ and for the beams B_1 and B_2 we have adopted height $h_B = 25.0\text{cm}$ while

$h_B = 15.0\text{cm}$ has been assumed for B_3 , B_4 and B_5 . It has been adopted Young's modulus $E = 25000\text{kNc/m}^2$, Poisson's ratio $\nu = 0.25$ and a distributed load of 0.03kN/cm^2 applied over the whole plate surface.

All plate sides are simply supported, but it is important to point out that in the model (BEM - I) the values $w = Mn = 0$ are prescribed along the plate external boundary while in the model (BEM - BA) they are prescribed along the beam axis. Therefore this example should present bigger differences between the numerical results, being smaller the displacements obtained for the model (BEM - BA). In the ANSYS analysis we have considered two simulations: (FEM-BA) and (FEM-EB). In the first analysis the deflection has been prescribed null along the external beam axis, while in the second one w was adopted null on the external boundary.

The deflection and moments are computed along the axis x'_1 and x_s , defined, respectively, in the middle of the bottom slab and on the B_4 axis (see Fig. 12).

For the (BEM - I) model we have considered one mesh with 122 nodes and 50 elements (see Fig. 13a) and another one containing 202 nodes and 90 elements. The poorest discretization adopted for the (BEM - BA) model contains 42 quadratic elements, resulting into 93 nodes defined along the beams axes (see Fig. 13b); 173 nodes and 82 elements have been considered in the finer mesh.

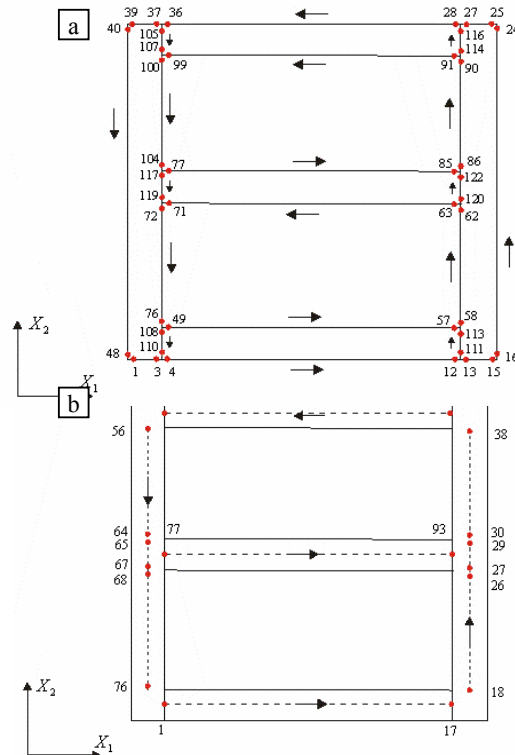

Fig. 13 Boundary discretizations a) Model (BEM - I) b) Model (BEM - BA)

For both models there was no significant difference between the two adopted meshes, excepted for the moment along B_4 axis, mainly for the (BEM-I) model (see Fig. 14).

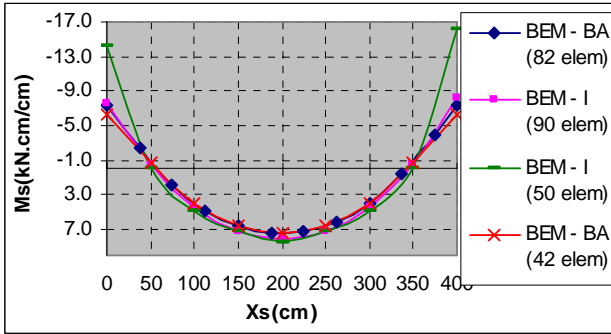

Fig. 14 Moment M_{ss} along B_4 axis

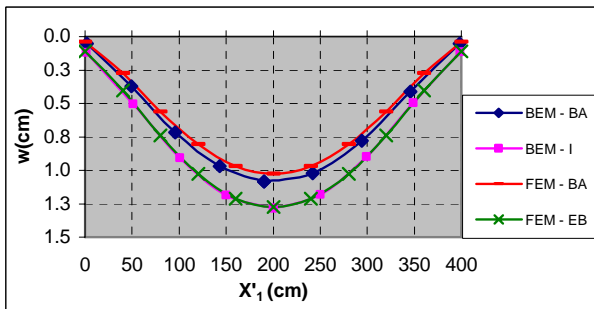

Fig. 15 Deflection in the plate, along x'_1 axis

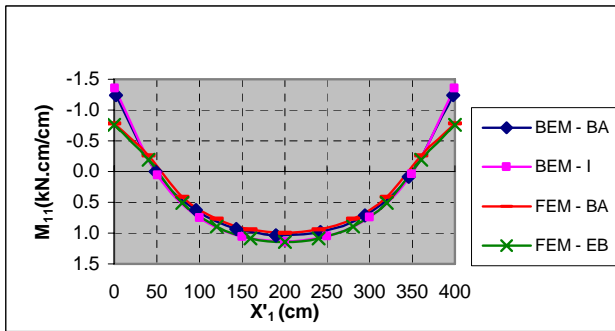

Fig. 16 Moment (M_{11}) in the plate, along x'_1 axis

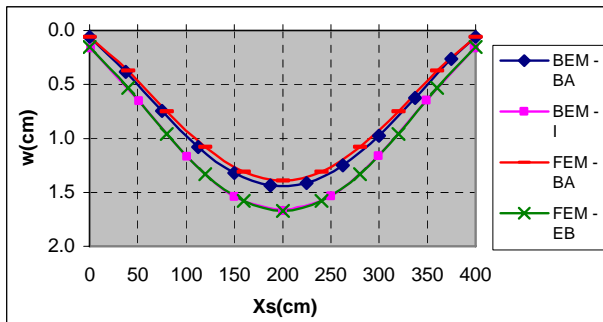

Fig. 17 Deflection in the beam B_4 along the axis x_s

The deflection and moment with respect to x_1 direction, along the x'_1 axis are displayed in Figs. 15 and 16. Figs. 17 and 18 show, respectively, deflection and moment with respect to s direction along B_4 axis. Note that the results

obtained for (BEM – I) compare very well with those referred to (FEM –EB), as well as the ones related to (BEM – BA) are similar to the ones computed considering (FEM – BA).

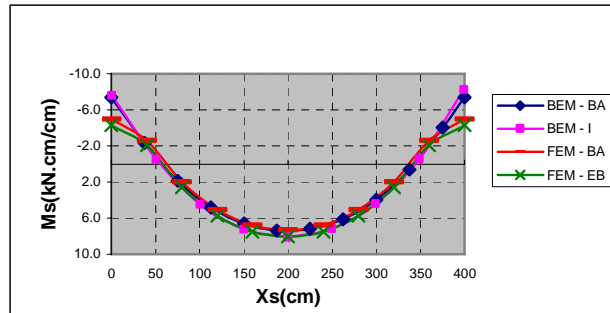

Fig. 18 Moment M_{ss} along B_4 axis

VI. CONCLUSION

Two formulations of the boundary element method - BEM to perform linear bending analysis of plates reinforced by beams have been discussed. The numerical results of both BEM models compare very well with those obtained considering a well-known finite element code. The advantage of the model (BEM BA) with respect to (BEM-I) is the reduction of the number of degrees of freedom and the simplification of the required mesh as well. For the (BEM-BA) model we have obtained the convergence results with poorer meshes if compared with the (BEM – I) model. As expected, the displacement obtained for (BEM – BA) are smaller than the ones computed with the model (BEM – I).

REFERENCES

- [1] Hu, C. & Hartley, G.A., Elastic analysis of thin plates with beam supports. *Engineering Analysis with Boundary Elements*, **13**: 229-238, 1994.
- [2] Hartley, G.A., Development of plate bending elements for frame analysis. *Engineering Analysis with Boundary Elements*, **17**: 93-104, 1996.
- [3] Tanaka, M. & Bercin, A.N., A boundary Element Method applied to the elastic bending problems of stiffened plates. In: *Boundary Element Method XIX*, Eds. C.A. Brebbia et al., CMP, Southampton, 1997.
- [4] Sapountzakis, E.J. & Katsikadelis, J.T., Analysis of plates reinforced with beams. *Computational Mechanics*, **26**: 66-74, 2000.
- [5] Fernandes, G.R and Venturini, W.S., Stiffened plate bending analysis by the boundary element method. *Computational Mechanics*, **28**: 275-281, 2002.
- [6] Hartmann, F. and Zotemantel, R., The direct boundary element method in plate bending. *International Journal for Numerical Methods in Engineering*, **23**(11): 2049-2069, 1986.
- [7] Paiva, J.B., Boundary element formulation of building slabs. *Engineering analysis with boundary elements*, **17**(2): 105-110, 1996.
- [8] Song, G.S. and Mukherjee, S., Boundary element method analysis of bending of elastic plates of arbitrary shape with general boundary conditions. *Engineering Analysis with Boundary Elements*, **3**: 36-44, 1986.
- [9] Kirchhoff, G. (1850). Über das gleichgewicht und die bewegung einer elastischen schleibe. *J. Math.*, n.40, p.51-58.