

Polymerisation Shrinkage of Light–Cured Hydroxyapatite (HA)–Reinforced Dental Composites

Bilge S. Oduncu, Sevil Yucel, Ismail Aydin, Isil D. Sener and Gokhan Yamaner

Abstract—The dental composites are preferably used as filling materials due to their esthetic appearances. Nevertheless one of the major problems, during the application of the dental composites, is shape change named as “polymerisation shrinkage” affecting clinical success of the dental restoration while photo-polymerisation. Polymerisation shrinkage of composites arises basically from the formation of a polymer due to the monomer transformation which composes of an organic matrix phase. It was sought, throughout this study, to detect and evaluate the structural polymerisation shrinkage of prepared dental composites in order to optimize the effects of various fillers included in hydroxyapatite (HA)-reinforced dental composites and hence to find a means to modify the properties of these dental composites prepared with defined parameters. As a result, the shrinkage values of the experimental dental composites were decreased by increasing the filler content of composites and the composition of different fillers used had effect on the shrinkage of the prepared composite systems.

Keywords—Dental composites, hydroxyapatite (HA), BisGMA, shrinkage.

I. INTRODUCTION

IN modern dentistry, one of the most important issue is esthetically repairing the structural problems of teeth by means of proper materials especially dental composites used mostly as the filling material. Therefore a great number of researches have been carried out for improving the properties of the dental composites throughout the world. Polymerisation shrinkage of dental resin composites is one of the main problems for clinicians during the restoration. Hence, any data on the shrinkage of such dental composites

could contribute for a successful and proper restoration.

Composite materials used in dental restorations consist of a continuous organic matrix phase such as a bisphenol A-glycidyl methacrylate (BisGMA) or urethane dimethacrylate (UDMA) diluted with triethyleneglycol dimethacrylate (TEGDMA) [1], [2] or hydroxyethylmethacrylate (HEMA) reinforced with a dispersed inorganic filler phase such as barium or zinc glasses, quartz, zirconia, silica, hydroxyapatite, etc. [3], [4].

The polymerisation shrinkage occurs as a result of exchanging the van der Waals spaces within the covalent bonds while monomers in the resin matrix are converted into polymer networks by the effect of visible-light [5]. As a result, such polymerisation shrinkage would create contraction stresses within the resin composite restoration as well as internal stresses and various forms of deformations in the surrounding tooth structure. Therefore leakages could occur at the stressed interfacial margin and contact area between the inner surface of teeth and the dental composite producing marginal staining and ultimately recurrent caries.

Several publications have determined the influence of polymerisation shrinkage on composite resin restorations [6]–[8]. Therefore, the primary aim of this study was to evaluate the magnitude of the shape change of composite resins obtained in the laboratory.

In this study, the shrinkage values of composites prepared were measured by means of a surface laser profiling system (OSP 100A, Uniscan, UK) and the calculated results were compared with the corresponding literature obtained by various methods. The composites, throughout this study, were obtained by using BisGMA (bisphenol A-glycidyl methacrylate) and HEMA (hydroxyethyl methacrylate) as the organic matrix phase and hydroxyapatite (HA), alumina and zirconia as the inorganic fillers with various amounts. The surfaces and hence the volumetric geometry of the prepared composites after curing (polymerisation) by LED type light were obtained by the OSP 100A surface profiling system. As a result, necessary calculations were implemented on the 3D shrinkage geometry constructed by the scan data. This scan was performed by recording “z-axis” data as the “depth” of the composite samples’ surface along the “x-axis” line with the defined steps along “y-axis”. After that, 3D geometries were analyzed by using MATLAB software package. An executable program was written to perform such analysis

B. S. Oduncu is with the Department of Bioengineering, Yildiz Technical University, Istanbul, TURKEY (e-mail: bilgesema@hotmail.com).

S. Yucel is with the Department of Bioengineering, Yildiz Technical University, Istanbul, TURKEY (e-mail: syucel@yildiz.edu.tr).

I. Aydin is with the Rheology Group, Department of Chemical Engineering, Engineering Faculty, Istanbul University, Avcilar Campus 34320, Istanbul, TURKEY (corresponding author, phone/fax: +90-212-5908646; e-mail: i.aydin@istanbul.edu.tr).

I. D. Sener is with the Department of Prosthodontics, Faculty of Dentistry, Marmara University, Buyuk Ciftlik S., No: 6, Nisantasi 34365, Istanbul, TURKEY (e-mail: isildamlasener@gmail.com).

G. Yamaner is with the Department of Endodontics, Faculty of Dentistry, Marmara University, Buyuk Ciftlik S., No: 6, Nisantasi 34365, Istanbul, TURKEY (e-mail: g.yamaner@gmail.com)

within the MATLAB software package. The microstructures of the prepared composites were examined by the SEM analysis. It was obtained that the shrinkage values decreased as the amount of inorganic filler phase increased and the composition of different fillers used had effect on the shrinkage of the prepared composite systems.

II. MATERIALS AND METHOD

A. Preparation of Dental Composites

Bisphenol A-glycidyl methacrylate (BisGMA as polymeric matrix) and hydroxyethyl methacrylate (HEMA) were mixed by using a mixing machine (PolyDrive Rheomix R600, ThermoHaake, Gebrüder Haake GmbH). After mixing for one hour, the mixture was taken and kept in a dark room. The initiator systems, camphoroquinone (CQ) and dimethyl amino ethyl methacrylate (DMAM) were added and the mixture was then stirred for another 12 hours in a dark ambience. Hydroxyapatite, as the main filler, and zirconia and alumina were added as inorganic fillers in different ratios to the mixture and stirred for six hours to obtain composite resins. The compositions of prepared dental composites are listed in Table I.

TABLE I
COMPOSITIONS OF PREPARED DENTAL COMPOSITES

Group	Filler phase % (w/w)		Filler % (v/v)	Matrix % (w/w)	Others
1a	60	75 HA and 25 Alumina (Sigma-Aldrich)	33.50	40 BisGMA and HEMA (50/50 wt%)	0.05% (w/w) CQ and DMAM
1b	65		38.50	35 BisGMA and HEMA (50/50 wt%)	
1c	70		43.75	30 BisGMA and HEMA (50/50 wt%)	
2a	60	75 HA and 25 Zirconia (Sigma-Aldrich)	31.50	40 BisGMA and HEMA (50/50 wt%)	
2b	65		36.50	35 BisGMA and HEMA (50/50 wt%)	
2c	70		42.00	30 BisGMA and HEMA (50/50 wt%)	

B. Measurement of Shape Change of Composites

Three dimensional surface profiles of before and after polymerisation of samples were carried out using the non-contacting Optical Surface Profiling System (OSP100A, Uniscan, UK) for the measuring of shape change (polymerisation shrinkage). The experimental surface scanning set-up is depicted in Figure 1.

In Fig. 1, the sample to be scanned was placed under the laser head and the distance between edge of the sample and the laser head was arranged. The height changes were calculated automatically by the software of the instrument while moving the laser head through x and y axes. The scan data obtained were recorded by the computer. These data were then converted into MATLAB program.

Each sample with 5 mm diameter and 2 mm thickness values were fixed under the instrument for profiling. All samples were cured by the Elipar Freelight LED for 20 seconds under 500 mW/cm². Each group of specimens were prepared and tested five times and the mean and standard deviations were also calculated.

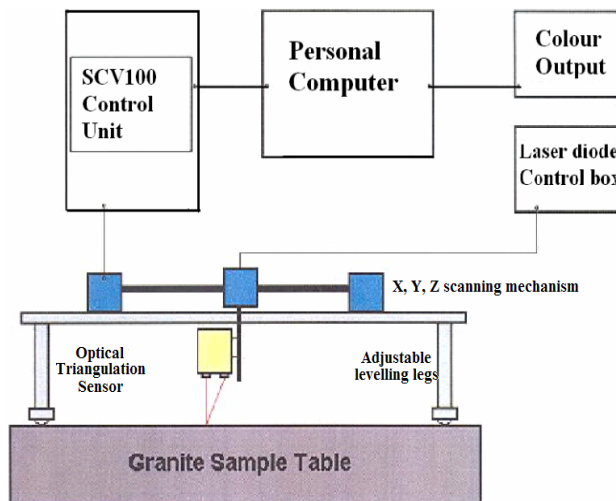

Fig. 1: Schematic illustration of OSP 100A Surface Profiling System

III. RESULTS

The mean values of polymerisation shrinkage at different inorganic phase contents with standard deviations are summarized in Table II. The data showed that the polymerisation shrinkage decreased by the increasing quantity of inorganic phase and the compositions of different fillers affected the shrinkage of dental composites. The data were found to be in agreement with the corresponding literature values [1] and [2]. Incorporating of alumina and zirconia into the composite resin system increased the polymerisation shrinkage.

TABLE II
POLYMERISATION SHRINKAGE VALUES OF DENTAL COMPOSITES

Sample Group Number (see Table I)	Polymerisation shrinkage after 30 min. % vol. (\pm STD)
1a	5.648 (0.0230)
1b	4.760 (0.0170)
1c	3.802 (0.0110)
2a	6.049 (0.0250)
2b	5.103 (0.0036)
2c	4.234 (0.0060)

The surface scan data for the samples 1a, 1b, 1c, 2a, 2b and 2c were depicted in Figs. 2-7, respectively, in the form of 3D and top views.

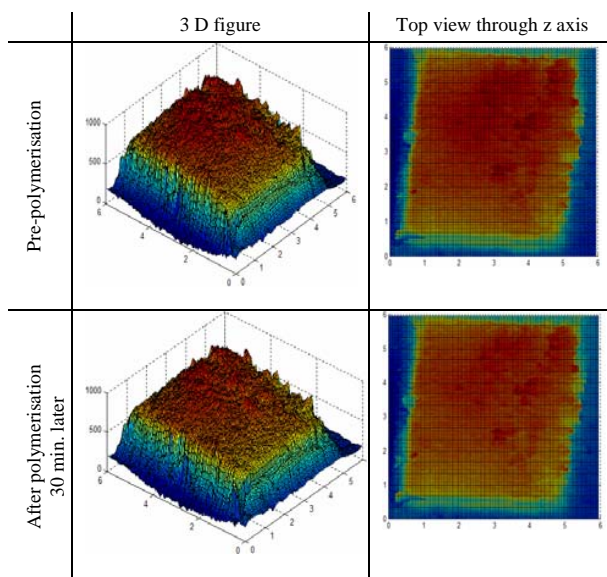

Fig. 3: Surface scan data for Sample 1b.

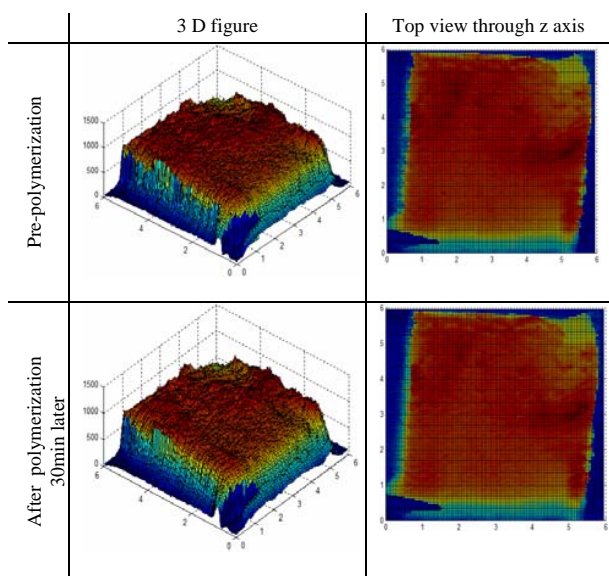

Fig. 2: Surface scan data for Sample 1a.

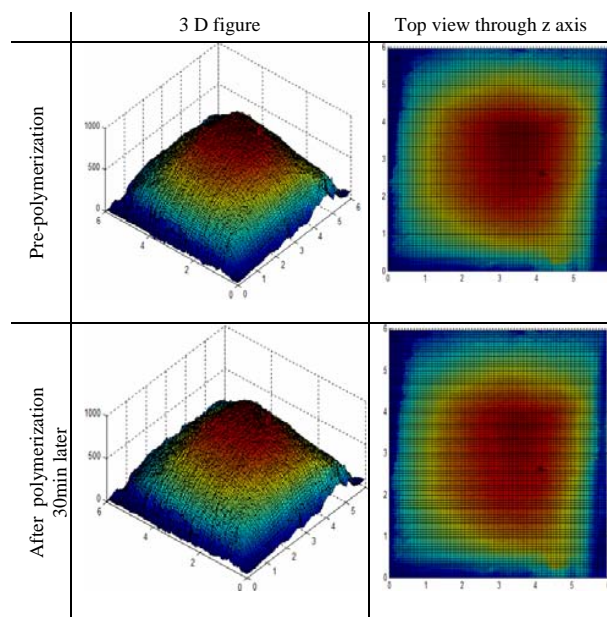

Fig. 4: Surface scan data for Sample 1c.

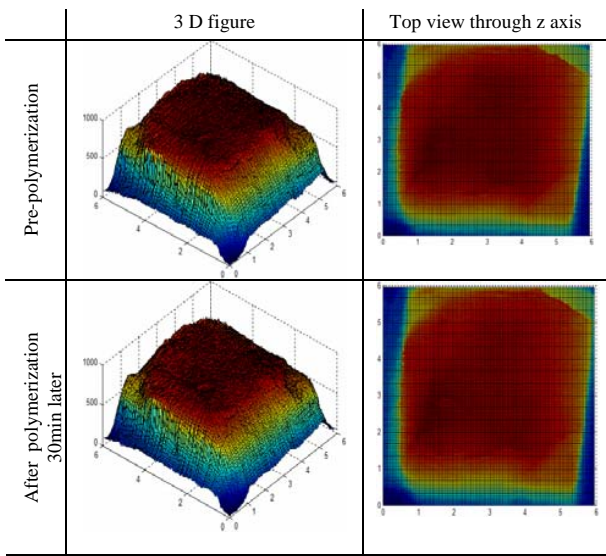

Fig. 5: Surface scan data for Sample 2a.

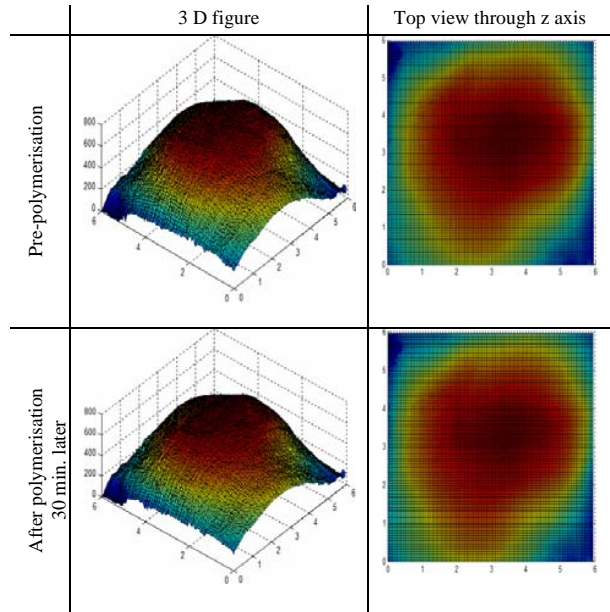

Fig. 7: Surface scan data for Sample 2c.

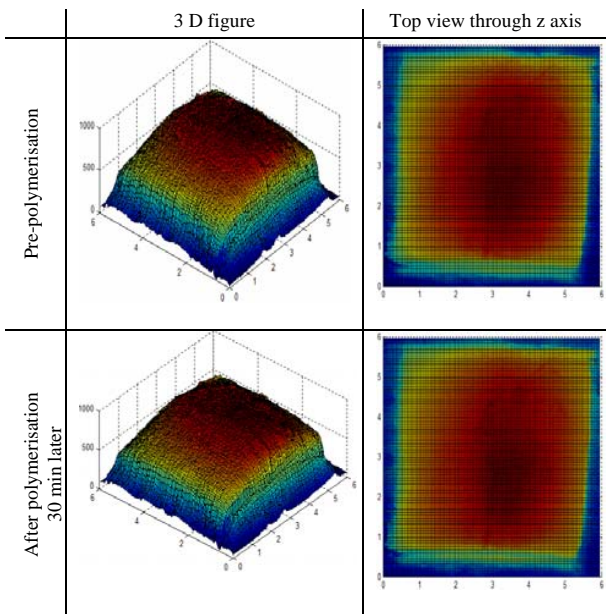

Fig. 6: Surface scan data for Sample 2b.

Effects of filler components ratio on the polymerisation shrinkage were shown in Fig. 8

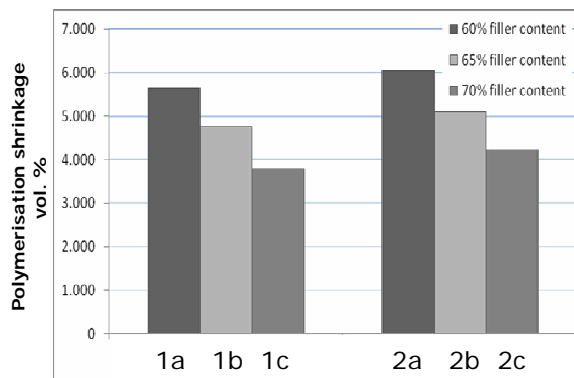

Fig. 8: Effect of filler components (%75 HA+%25 Alumina for 1a, 1b and 1c, and %75 HA+%25 Zirconia for 2a, 2b and 2c) ratio on the polymerisation shrinkage.

SEM photos were depicted for each group of the prepared dental composites in Fig. 9.

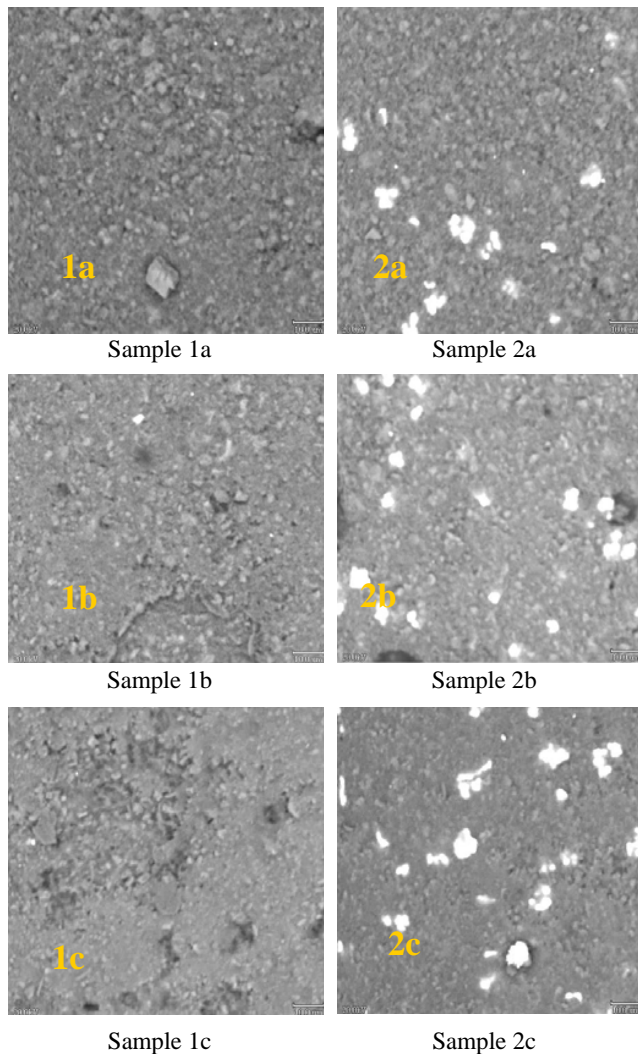

Fig. 9 SEM photos for each group of the prepared dental composites.

IV. DISCUSSION

It was observed from the scan data (Figures 2-7) that each surface had different morphology than the others. The polymerisation shrinkage of 70% (w/w) HA/alumina (75/25) composite sample was measured to be 3.802%. This dental composite sample 1c has the highest filler amount. Also the other composite groups showed various shrinkage values depending upon the effect of filler component amount. The effect of filler amount on the shrinkage is clearly seen in Fig. 8.

Different surface properties and appearances could be seen from SEM photos in Fig. 9. It was observed from SEM pictures that the polymerisation curing on the surface of HA/zirconia composites was more homogenous than HA/alumina composites.

The volume fractions of the composite materials containing 60%, 65% and 70% weight ratios of filler content were given

in Table I. In this Table, the volume fraction values were calculated by means of the density values of HA, alumina and zirconia taken as 3.516 g/cm^3 , 3.970 g/cm^3 and 6.050 g/cm^3 , respectively. It was seen from these calculations that there was a relationship between the volumetric shrinkage values and the volume ratios. The shrinkage value of HA/zirconia composite was higher than HA/alumina composite since "organic phase / filler phase" ratio was higher for HA/zirconia composite than HA/alumina composite. It is expected since the density of zirconia is higher compared with the alumina. It was also measured that the shrinkage values were affected by the different ratios of the same filler content in the experimental dental composites (Fig. 8).

V. CONCLUSION

In all samples, the 3D surface geometry of the dental composites, after light curing, exhibited a convex shape forming a hill at the top. It was concluded from this study that after a certain time where polymerisation was activated due to the applied light source, monomers mixed with the filler phase begin polymerisation while contracting more and faster at the (Fig. 10) edges than in the middle part of the mold due to the

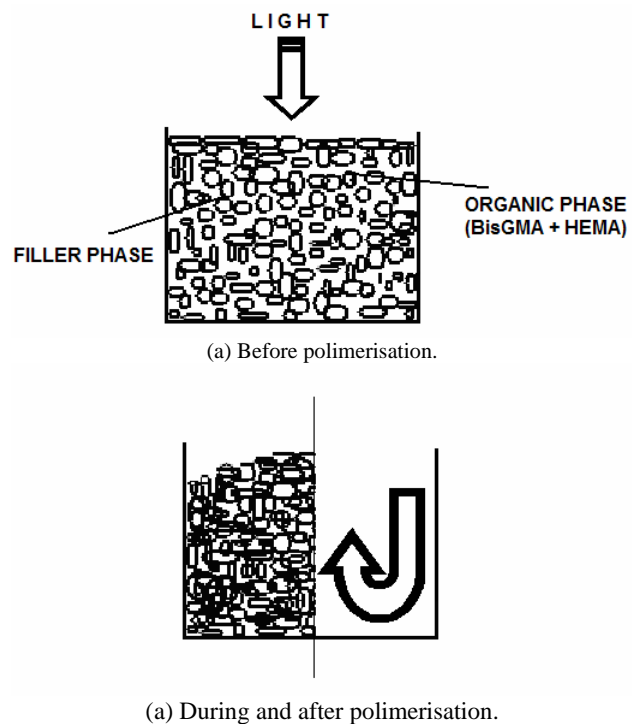

Fig. 10: Formation of surface geometry of the dental composites a) before polymerisation and, b) during and after polymerisation process (activated by the LED light source).

resultant forces preventing the material movement in middle (central axis) of the dental composite. Of course, there are

other factors affecting the formation of such a shape which is under investigation by the current research.

The polymerisation shrinkage values of the composites obtained were changed between 6.04-3.80% (v/v). The shrinkage values varied by changing the amount of the filler components. Hence, such parameter can be used for the control of polymerisation shrinkage of dental composites. Polymerisation shrinkage were also decreased relating with respect to the volume fractions of the fillers. The lowest volumetric shrinkage value was exhibited by the 70% (w/w) HA/alumina composites since the density of alumina was less than the zirconia. Hence, a precise combination of such fillers could be used for the reduction of polymerisation shrinkage occurring during the photo-polymerisation of dental composites.

REFERENCES

- [1] R. L. Bowen and W. A. Marjenhoff, "Dental composites/glasses ionomer: The materials," *Adv. Dent. Res.*, vol. 6, pp. 44-49, 1992.
- [2] E. Asmussen and A. Peutzfeldt, "Influence of UEDMA, Bis-GMA and TEGDMA on selected mechanical properties of experimental resin composites," *Dent. Mater.*, vol. 14, pp. 51-56, 1998.
- [3] G. Willems, P. Lambrechts, M. Braem, J. P. Celis and G. Vanherle, "A classification of dental composites according to their morphological and mechanical characteristics", *Dent. Mater.*, vol. 8, pp. 310-319, 1992.
- [4] R. W. Phillip, *Skinner's Science of Dental Materials*. Philadelphia: Saunders, 9th ed., 1991.
- [5] A. Peutzfeldt, "Resin composites in dentistry: The monomer systems," *Eur. J. Oral Sci.*, vol. 105, pp. 97-116, 1997.
- [6] B. M. Griffiths, M. Naasan, M. Sherriff and T. F. Watson, "Variable polymerization shrinkage and the interfacial microporosity of a dentin bonding system," *J. Adhes. Dent.*, vol. 1, pp. 119-131, 1999.
- [7] P. Koran and R. Kurschner, "Effect of sequential versus continuous irradiation of a light-cured resin composite on shrinkage, viscosity, adhesion and degree of polymerization," *Am. J. Dent.*, vol. 11, pp. 17-22, 1998.
- [8] G. L. Unterbrink and W. H. Liebenberg, "Flowable resin composites as filled adhesives: literature review and clinical recommendations," *Quintessence*, vol. 30, pp. 249-257, 1999.