

Evaluation of the Zero Sequence Impedance of Overhead High Voltage Lines

Rabah Diabi

Abstract—As known, the guard wires of overhead high voltage are usually grounded through the grounding systems of support and of the terminal stations. They do affect the zero sequence impedance value of the line, Z_0 , which is generally, calculated assuming that the wires guard are at ground potential. In this way it is not considered the effect of the resistances of earth of supports and stations. In this work is formed a formula for the calculation of Z_0 which takes account of said resistances. Is also proposed a method of calculating the impedance zero sequence overhead lines in which, in various sections or spans, the guard wires are connected to the supports, or isolated from them, or are absent. Parametric analysis is given for lines 220 kV and 400 kV, which shows the extent of the errors made with traditional methods of calculation.

Keywords—Overhead line, power system, zero sequence, wire guard, grounding.

I. INTRODUCTION

THE impedance Z of overhead power lines is calculated by the symmetric matrix of impedances longitudinal per unit length, whose elements are calculated with the well-known theory of Carson [1, 2].

The impedance Z of overhead power lines is calculated by the symmetric matrix of impedances longitudinal per unit length, whose elements are calculated with the well-known theory of Carson [1,2].

For line with three phase conductors and a wire guard (FG), the matrix is as follows:

$$Z = \begin{bmatrix} Z_{11} & Z_{12} & Z_{13} & Z_{14} \\ Z_{12} & Z_{22} & Z_{23} & Z_{24} \\ Z_{13} & Z_{23} & Z_{33} & Z_{34} \\ Z_{14} & Z_{24} & Z_{34} & Z_{44} \end{bmatrix} \quad (1)$$

The self impedances Z_{ii} and their mutual Z_{ij} are:

$$Z_{ii} = r_i + f\pi^2 10^{-4} + j0.46\omega \log_{10}(D_e/r_{gei})10^{-3}$$

$$Z_{ij} = f\pi^2 10^{-4} + j0.46\omega \log_{10}(D_e/D_{ij})10^{-3} [\Omega/\text{km}]$$

r_{gei} :[m]Geometric equivalent radius of the conductor

R_i :[Ω / km] AC resistance of the conductor i

D_{ij} : [m] distance between conductors i and j

D_e : [m] Depth of the center of gravity of return ground currents determined by $D_e = 658\sqrt{\rho_t/f}$ (ρ_t [Ωm] soil resistivity f [Hz] frequency)

$f\pi^2 10^{-4}$: [Ω / km] kilometric resistance of the soil .

The impedance Z_0 is defined as the arithmetic average of apparent impedances of the three phases to the zero sequence. This is equivalent to consider in (1) the average values of self and mutual impedances:

$$Z_c = (Z_{11} + Z_{22} + Z_{33}) / 3 \quad \text{Instead of } Z_{11}, Z_{22}, Z_{33}$$

$$Z_{mc} = (Z_{12} + Z_{13} + Z_{23}) / 3 \quad \text{Instead of } Z_{12}, Z_{13}, Z_{23}$$

$$Z_{mcf} = (Z_{14} + Z_{24} + Z_{34}) / 3 \quad \text{Instead of } Z_{14}, Z_{24}, Z_{34}$$

$$Z_f = Z_{44} \quad (2)$$

By requiring that the three phases are traversed by a system zero sequence current, we obtain the following expressions of Z_0 :

-FG to ground in each support with earth resistance $R_p = 0$

$$Z_0 = Z_c + 2Z_{mc} - 3Z_{mcf} / Z_f \quad (3)$$

-FG isolated from the support and from the earth of the station:

$$Z_0 = Z_c + 2Z_{mc} \quad (4)$$

The (3) and (4) give respectively the minimum and maximum value $|Z_0|$ can take. If the wire guard is grounding, $|Z_0|$ is smaller when the mutual impedance conductor-FG is greater and the impedance of the cable itself smaller: both circumstances do in fact increase the share of the zero sequence current flowing in the FG.

Conversely, if the FG is isolated from ground, it is not crossed by currents zero sequence (if not negligible due to the capacitive coupling) and therefore Z_0 depends only from zero sequence currents which close in the ground.

The (3) is generally used for the calculation of Z_0 because the FG is, if not in applications specials [3,4], connected to the land of the supports and terminal stations. Sometimes to limit the current that circulates in the FG in the event of an earth fault on the first support line, the FG is not connected to the land station. R_p has a value of about ten ohms in case of soils with low resistivity, up to hundreds of ohms in the case of rocky terrain, while the resistance of earth stations, R_s , varies

from 1-2 Ω to fractions of ohms in the case of stations of HV. The zero sequence currents in phase conductors on FG induce an e.m.f which a current is flowing in the wire of the same entity employee from Rp and Rs.

To better illustrate this, consider the circuit of Fig. 1(a), in which are represented the three phase conductors of a span of length c paths from zero sequence currents and the FG connected to two supports of equal ground resistance Rp. It is reasonable to neglecting the transverse admittance of the conductors. For each phase conductor and for the FG can be written the following equations:

$$\begin{aligned} E'_{c0} - E_{c0} &= (Z_c + 2Z_{mc})cI_0 + Z_{mcf}cI_f \\ -3Z_{mcf}cI_0 &= (2R_p + Z_f c)I_f \end{aligned} \tag{5}$$

The second equation gives:

$$I_f = -3Z_{mcf}cI_0 / (2R_p + Z_f c) \tag{6}$$

which substituted in the first equation gives:

$$\begin{aligned} Z_0 &= (E'_{\infty} - E_{\infty}) / I_0 c = \\ &= (Z_c + 2Z_{mc}) - 3Z_{mcf}^2 / ((2R_p / c) + Z_f) \end{aligned} \tag{7}$$

The (6) and (7) show the influence of the resistances of ground of the supports on the value of the current flowing in FG and then the Z0. In fact for Rp = 0, the current circulating in FG closes through the ground and is limited to only the impedance of the cable:

$$I_f = -3I_0 Z_{mcf} / Z_f \tag{8}$$

If the FG is isolated from ground, from (1.5) is If = 0. If than 0 < Rp < ∞ the If may close in the ground through the supports but is also limited by the resistors of ground of the same.

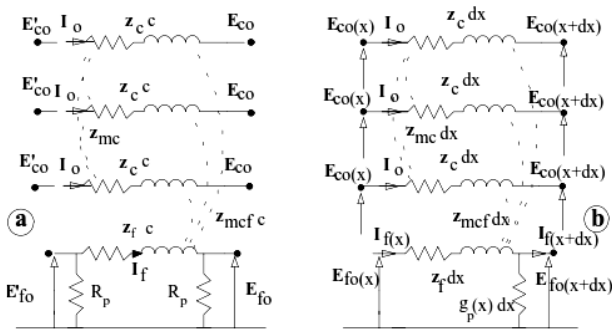

Fig. 1 (a) Equivalent circuit for a span of an overhead line, (b) primary circuit of length dx, the system conductor-wire guard-resistance grounding of the supports

II. EFFECT OF EARTH RESISTANCES OF SUPPORT AND STATION ON THE ZERO SEQUENCE IMPEDANCE LINES

The (1.6) is not exact because it ignores the line in throughout its length and does not take into account the resistances Ground the FG terminal stations which are normally connected. To calculate more accurately Zo you can use the equivalent circuit of the system conductors-FG-resistance ground of the supports of Fig. 1 [5,6,7,8], where it was considered the conductance of the ground of supports per unit length, gp (x), suppository evenly distributed and defined by the relation (ci the length of the span on the i-th wind support):

$$g_p(x) = 1/R_{pi} c_i = 1/r_p(x) \tag{9}$$

In general the magnitudes gp (x) and rp (x) are variables along the line, depending on the resistance of the ground individual support, Rpi, and c the length of the span.

However, for the purposes of the calculation of Zo, is often lawful replace gp (x) and rp (x) by the average values calculated for the whole line, gm and rm.

If we neglect the transverse admittance to the land of phase conductors, the zero sequence current Io the same is constant at all points of the line. Writing the equations of the elementary network Fig. 1 and integrating between the two ends of the line obtain the equations of the two-port equivalent the zero sequence of the entire line. From them finally obtains the equivalent circuit of Fig. 2, which takes account of the resistance grounding of the supports and in which were also reported resistors ground of the two stations at the ends of the line, Rs1 and Rs2.

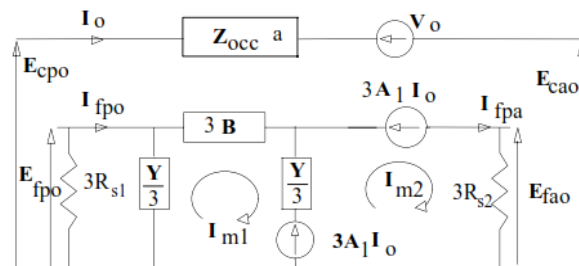

Fig. 2 Equivalent circuit of the line to the zero sequence taking account of ground systems of support and stations

In Fig. 2 the symbols have the following meaning:

Ecp0, Eca0, Efp0, Efa0 are voltages zero sequence conductor-to-ground and voltage FG-to-ground at the start and upon arrival of the line of length "a".

Io: zero sequence current in phase conductor;
Ifpo, Ifao: 1/3 of the currents at the ends of FG;

$$\begin{aligned} Z_{occ} &= Z_c + 2Z_{mc} \\ A &= \cosh(k_f a) \quad B = Z_{of} \sinh(k_f a) \\ Z_{of} &= \sqrt{(Z_f / g_m)} \quad K_f = \sqrt{Z_f g_m} \end{aligned}$$

$$\begin{aligned}
 Y &= (A-1)/B \\
 V_0 &= 3A_3I_0 - A_2E_{fp0} + 3A_1I_{fp0} \\
 A_1 &= (Z_{mcf}/k_f) \sinh(k_f a) \\
 A_2 &= (Z_{mcf}/Z_{ff}) [\cosh(k_f a) - 1]
 \end{aligned}$$

From the expression of V_0 above, using analytical developments, we obtain:

$$V_0 = -3(Z_{mcf}^2/Z_f^2) [Z_f a - (1/(Y_{s12} + 1/B))] I_0 \quad (10)$$

Y_{s1} series of the admittances $Y_{p1} = Y + 1/R_{s1}$ and $Y_{p2} = Y + 1/R_{s2}$;

Therefore, the following expression is obtained zero sequence impedance Z_0 or overhead line with FG:

$$Z_0 = (Z_c + 2Z_{mc}) - 3(Z_{mcf}^2/Z_f^2 a) (Z_f a - (1/(Y_{s12} + 1/B))) \quad (11)$$

where Z_p : is the impedance parallel between B and $1/Y_{s12}$.

From (11) we observe that:

a) if the earth resistances $R_{s1} = R_{s2}$ stations are invalid, void, or if you take the resistance of the ground R_p of the supports, $Y_{p1} = Y_{p2} = \infty$, $Z_p = 0$ and therefore the (11) coincides with (2).

b) if the FG are isolated from the supports ($g_m = 0$, $B = aZ_f$ and $Y = 0$), but are connected to networks of ground substations at the two ends of the line, since there are indications $Y_{s12} = 1/(R_{s1} + R_{s2})$ the Z_0 is much closer to the value provided by (1.2), the lower the value of R_{s1} and R_{s2} , because it is:

$$Z_0 = (Z_c + 2Z_{mc}) - 3(Z_{mcf}^2 a / (R_{s1} + R_{s2} = Z_f a))$$

c) if the FG are not connected to mains earth of substation (which is equivalent to considering $R_{s1} = R_{s2} = \infty$) the value of Z_0 and depends only R_p on the length of the line (in addition to Z_f and Z_{mcf}):

$$Z_0 = (Z_c + 2Z_{mc}) - 3(Z_{mcf}^2/Z_f a) ((Z_f a) - ((Y/2) + (1/B)))$$

in the latter case, for long lines and / or equipped with low R_p , resulting in $|\cosh(K_f a)| \gg 1$ then (2.3) becomes in the simplest:

$$Z_0 = (Z_c + 2Z_{mc}) - 3(Z_{mcf}^2/Z_f a) ((Z_f a) - (2Z_{Of}))$$

Z_{Of} is the characteristic impedance of the system of wire guard-resistance grounding of the supports;

If the FG is not connected to the supports or are not present in some sections of the line, consider the circuit equivalent of Fig. 3.

For the phase conductor can be then write the following relation:

$$\begin{aligned}
 E_{0p} - E_{0a} &= (E_{0p} - E'_{0}) + (E'_{0} - E''_{0}) + \dots + (E''_{0} - E_{0a}) = \\
 &= Z_{0cc} a I_0 + V_{01} + V_{02} + \dots + V_{0n}
 \end{aligned} \quad (12)$$

Where the e.m.f induced by the currents flowing in the FG on the phase conductor, V_{0i} , are different from zero only in sections where FG are attached to the supports.

The i -th section of the length in which the rope is connected to the supports, V_0 is equal to:

$$V_0 = -3(Z_{mcf}^2/Z_f^2) [Z_f a_i - (1/(Y_{si} + 1/B_i))] I_0 \quad (13)$$

In addition it has:

$$\begin{aligned}
 Y_{S1} &= [Y_1(Y_1 + 1/R_1)] / (2Y_1 + 1/R_1) \\
 Y_{Sn} &= [Y_n(Y_n + 1/R_2)] / (2Y_n + 1/R_2) \\
 Y_{si} &= Y_i / 2
 \end{aligned} \quad (14)$$

Y_{s1} and Y_{s2} are the admittances of the first series and last line is connected with FG respectively to the lands of the station 1 and 2; Y_i is the admittance series of i -th line with wire guard attached to the supports.

Ultimately from is obtained:

$$Z_0 = Z_{0cc} - 3(Z_{mcf}^2/Z_f^2 a) \left[(Z_f \sum_{i=1}^{mn} a_i) - (\sum_{i=1}^{mn} (1/(Y_{si} + 1/B_i))) \right] \quad (15)$$

mn : is the number of sections in line with FG attached to the brackets.

Finally in case you want to represent even more in detail the overhead power line, that is, bring into account the actual resistances of the earth of each support and change in self and mutual impedances of the different conductors to vary the geometry of the support, is must write the reports of the $n-1$ tree poles representatives of the bans of the line and then evaluate the equivalent set.

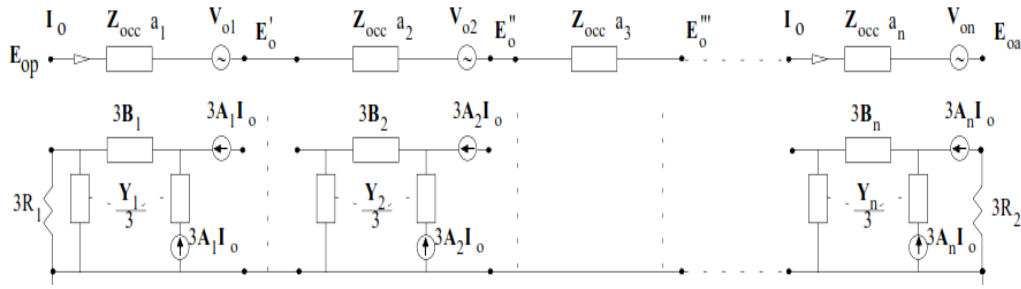

Fig. 3 Equivalent circuit of the zero sequence line with FG in the non-earthed or not present

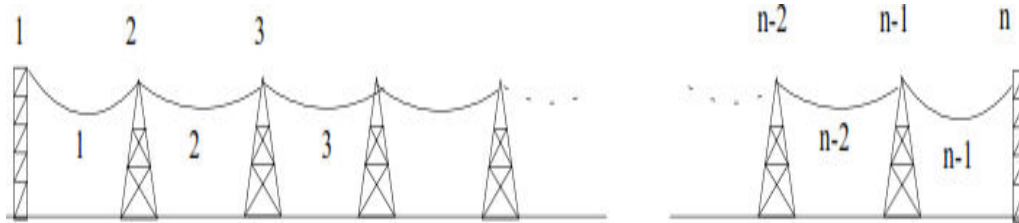

Fig. 4 Line to n spans

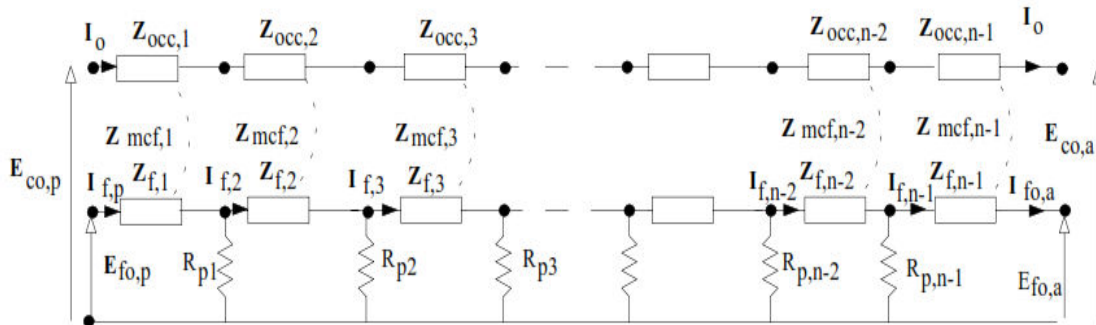

Fig. 5 equivalent circuit zero sequence for line ($Z_{occ, i} = Z_{cc, i} + 2 Z_{mc, i}$, where $Z_{cc, i}$, and $Z_{mc, i}$ are the self and mutual impedance of the phase of the i th bay)

Referring to Fig. 4 and 5 where they are represented the $n-1$ spans constituting the line, we can write the following relations:

a) For the System Wire Guard-Support:

$$\begin{bmatrix} E_{f0p} \\ I_{f0p} \end{bmatrix} = \begin{bmatrix} D & B \\ C & A \end{bmatrix} \begin{bmatrix} E_{f0a} \\ I_{f0a} \end{bmatrix} + \begin{bmatrix} E \\ F \end{bmatrix} I_0 \quad (16)$$

$$\begin{bmatrix} D & B \\ C & A \end{bmatrix} = \prod_{i=1}^{n-1} [T_i]$$

$$\begin{bmatrix} E \\ F \end{bmatrix} = \left\{ [M_1] + \sum_{i=2}^{n-1} \left\{ \prod_{j=1}^{i-1} [T_j] \right\} [M_i] \right\}$$

for $i=1, \dots, n-2$ result:

$$[T_i] = \begin{bmatrix} 1 + (Z_{fi}/R_{pi}) & 3Z_{fi} \\ 1/3R_{fi} & 1 \end{bmatrix}$$

$$[M_i] = \begin{bmatrix} 3Z_{mcfi} \\ 0 \end{bmatrix}$$

$$[T_{n-1}] = \begin{bmatrix} 1 & 3Z_{f, n-1} \\ 0 & 1 \end{bmatrix} \quad (17)$$

b) For each Phase Conductor:

$$E_{c0p} = E_{c0a} + \left(\sum_{j=1}^{n-1} Z_{occj} \right) I_0 + \left(\sum_{j=1}^{n-1} 3Z_{mcfj} I_{f0j} \right)$$

$$I_{f0j} = I_{fj} / 3 = C_j E_{f0a} + A_j I_{f0a} + F_j I_0$$

$$\begin{bmatrix} D_j & B_j \\ C_j & A_j \end{bmatrix} = \prod_{i=j}^{n-1} [T_i] \quad \begin{bmatrix} E_j \\ F_j \end{bmatrix} = \left\{ [M_j] + \sum_{i=j+1}^{n-1} \left\{ \prod_{k=j}^{i-1} [T_k] \right\} [M_i] \right\}$$

(18)

We obtain

$$\Delta E = E_{c0p} - E_{c0a} =$$

$$\Delta E = \sum_{j=1}^{n-1} Z_{Occj} I_0 + M_A I_0 + M_B E_{f0a} + M_C I_{f0a} \quad (19)$$

From (18) and (19) result the equivalent circuit in Fig. 6.

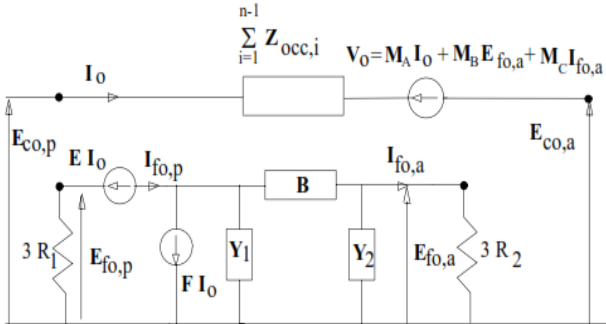

Fig. 6 Equivalent circuit for the zero sequence overhead lines represented in detail ($Y_1 = (A - 1) / B$, $Y_2 = (D - 1) / B$)

Solving the circuit on the rope-supports Fig. 6 we obtain the expressions of the current and voltage arrival of the rope guard function of the zero sequence current on the conductor phase, I_0

$$\begin{aligned} E_{f0a} &= -((E / 3R_{t1} + F) / (Y_{p1} + Y_{p2} + Y_{p1} Y_{p2} B)) I_0 \\ I_{f0a} &= E_{f0a} / 3R_{t2} \end{aligned} \quad (20)$$

$$Y_{p1} = Y_1 + 1 / R_1 \text{ and } Y_{p2} = Y_2 + 1 / R_2$$

The latter, introduced in (19) provide the following expression for the calculation of the impedance zero sequence line:

$$\begin{aligned} Z_0 &= (E_{c0p} - E_{c0a}) / a I_0 \\ ZM &= M_A + \sum_{j=1}^{n-1} Z_{Occj} \\ YY &= Y_{p1} + Y_{p2} + Y_{p1} Y_{p2} B \\ MM &= ((E / 3R_{t1}) + F) ((M_B + M_C / 3R_{t2})) \\ Z_0 &= a^{-1} (ZM - (MM / YY)) \end{aligned} \quad (21)$$

The above-mentioned procedure for the calculation of Z_0 , implemented on a computer, allows taking into account also the cutting and / or non-presence of wire guard in various sections of the line.

For example, consider a line to 220kV, 50Hz with the following characteristics:

Lengths: 5 km and 50 km, the phase conductors in Al-Ac with $dc = 26.1$ mm and $Rc20^\circ C = 0.0824 \Omega / \text{km}$, a FG in Al-Ac with $df = 11.35$ mm and $Rf20^\circ C = 0.646 \Omega / \text{km}$, grounded in all supports; span: 400 m, the average value of $R_p = 20 \Omega$ and $\rho_t = 100 \Omega \cdot \text{m}$, $R_{s1} = R_{s2} = 1 \Omega$.

We obtain:

$$\begin{aligned} Z_{cc} &= 0.1317 + j 0.7155 \Omega / \text{km} \\ Z_{mc} &= 0.0493 + j 0.3209 \Omega / \text{km} \\ Z_f &= 0.6953 + j 0.7676 \Omega / \text{km} \\ Z_{mcf} &= 0.0493 + j 0.2938 \Omega / \text{km} \\ Z_{occ} &= 0.2303 + j 1.357 \Omega / \text{km} \\ G_m &= 0.125 \Omega^{-1} \\ Z_{of} &= 2.6313 + j 1.1669 \Omega / \text{km} \\ K &= 0.3289 + j 0.1459 \text{ 1/km} \end{aligned}$$

Length.	5 km	50 km
$B[\Omega]$	$3.3318 + j 6.7079$	$(2.8611 + j 19.77) 10^6$
$Y [\Omega^{-1}]$	$0.2581 - j 0.0406$	$0.3176 - j 0.1408$
$Y_{p1} =$	$1.2581 - j 0.0406$	$1.3176 - j 0.1408$
$Y_{p2} [\Omega^{-1}]$		

The zero-sequence impedance kilometric calculated with (11) is:

- For $L = 5$ km, $Z_0 = 0.347 + j 1.191 \Omega / \text{km}$
While if the FG is considered to ground potential ($R_p = 0$) is $Z_0 = 0.331 + j 1.121 \Omega / \text{km}$: the error is - 4.6% of R_0 and - 6% of X_0 .

If instead the FG is considered to be isolated from ground, $Z_0 = 0.230 + j 1.357 \Omega / \text{km}$: the error is + 14% of X_0 and - 34% of R_0 .

If the FG is connected to the supports and is not connected to the earth station is $Z_0 = 0.279 + j 1.329 \Omega / \text{km}$:

Value much closer to that in the case of FG insulated from earth, which nevertheless provide an R_0 value affected by an error of -17.5%.

- For $L = 50$ km, $Z_0 = 0.334 + j 1.128 \Omega / \text{km}$
Value coincident with that calculated with $R_p = 0$.

Or if the line is composed of the following five sections: 30 km with FG to ground, 2 km with FG isolated; 10 km with FG ground, 2 km with FG isolated; 6 km with FG on the ground, (13) provides: $Z_0 = 0.322 + j 1.203 \Omega / \text{km}$.

The Z_0 calculated with (11) is in this case affected by a error of +3.7% on R_0 and -6.3% on X_0 .

For $L = 5$ km and 50 km values of Z_0 calculated with (11) are coincident with those calculated with (21).

If the line is not homogeneous (11) provides values of Z_0 practically coincide with those obtained from (21), if they are considered to be the weighted average values of the elements Z_{ij} , and R_p . For example for the line to 220 kV under consideration, with a length of 10 km divided into two sections 4 and 6 km, with support with earth resistance respectively 20 and 10 Ω , the (11) provides: $Z_0 = 0.329 + j 1.116 \Omega / \text{km}$: the same value is calculated as (21) whereas for R_p is the average value of 12.5 Ω .

III. PARAMETRIC ANALYSIS FOR LINES 220 KV AND 400 KV

Below is reported a parametric analysis for the calculation of Z_0 lines at 220 and 400 kV, by means of the formula (11).

In Fig. 7 and 8 are reported for the line at 220 kV, 50 Hz considered above, the trends of zero sequence reactance and resistance kilometric, X_0 and R_0 , depending on the length of line, for different pairs of values of R_p and soil resistivity, ρ_t . The FG Al-Ac with $d = 11.35$ mm is considered to be

connected the earth station with $R_{S1} = R_{S2} = 1 \Omega$ or isolated from them.

Fig. 9 shows the trends of R_o and X_o function of the line length and the variation of R_p and ρ_t , for a line to 400kV/50Hz with three conductors per phase in the Al-Ac, $d = 30.42\text{mm}$, $R_{c20^\circ\text{C}} = 0061 \Omega / \text{km}$, and two FG in Al-Ac with the same characteristics of the considered for the line 220kV. The cables are connected to the earth of the two stations at the ends with $R_{S1} = R_{S2} = 0.5 \Omega$.

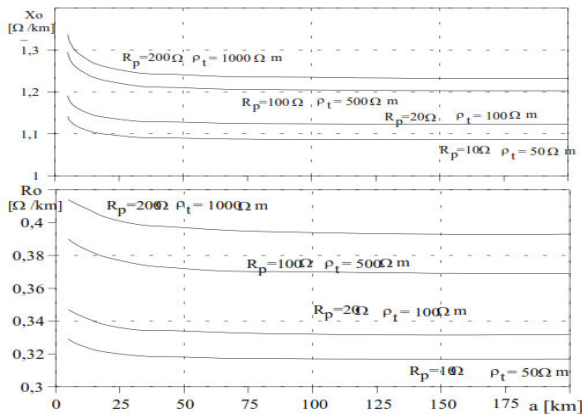

Fig. 7 Line 220 kV-50 Hz with FG in Al-Ac, connected to the earth station ($R_{S1} = R_{S2} = 1\Omega$): performance of X_o and R_o vary the length of the line, for different values of R_p and ρ_t

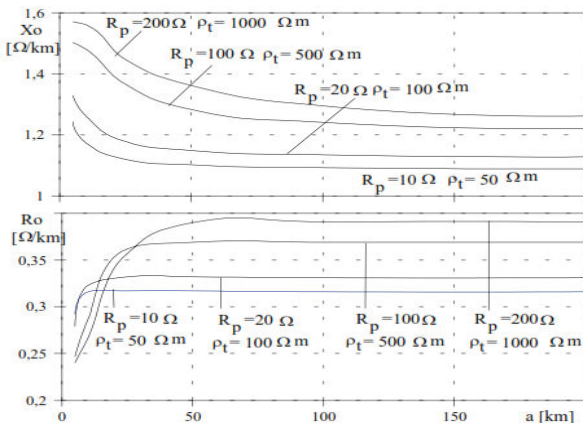

Fig. 8 Line 220 kV-50 Hz with FG in Al-Ac not connected to the earth station: performance of X_o and R_o vary the length of the line, for different values of R_p and ρ_t

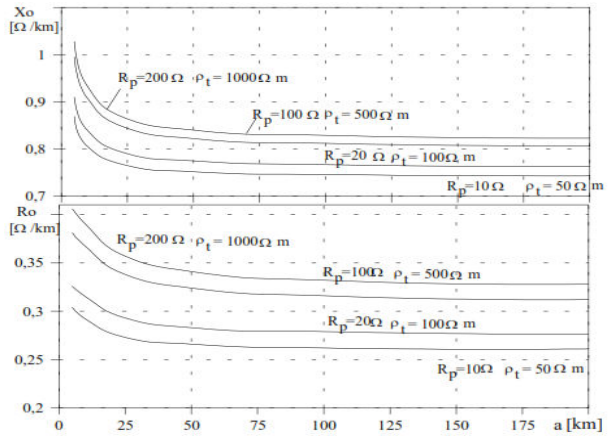

Fig. 9 Line 400 kV-50 Hz with two safety cables in Al-Ac connected to the earth station ($R_{S1} = R_{S2} = 0.5 \Omega$): performance of X_o and R_o vary the length of the line, for different values of R_p and ρ_t

In Table I are finally shows the values of R_o and X_o for these lines at 220 kV and 400 kV, calculated assuming the FG at ground potential or isolated from earth.

TABLE I
VALUES OF R_o AND X_o OF THE LINES AT 170KV AND 420 KV CALCULATED ASSUMING THE FG AT GROUND POTENTIAL OR ISOLATED

ρ_t [Ω/km]	R_o, X_o [Ω/km]	Line at 220Kv		Line at 400kV	
		State of FG		State of FG	
		Vf=0	Ins	Vf=0	Ins
50	R_o	0.36	0.230	0.259	0.163
	X_o	1.085	1.292	0.739	1.073
100	R_o	0.331	0.230	0.274	0.164
	X_o	1.121	1.357	0.759	1.136
500	R_o	0.368	0.230	0.308	0.167
	X_o	1.200	1.509	0.802	1.285
1000	R_o	0.392	0.230	0.323	0.167
	X_o	1.229	1.574	0.818	1.350

*) Values of Z_o vary with the soil resistivity ρ_t since, varying the depth of the ground return currents: vary the elements of the matrix of kilometric impedance(self and mutual) of the line.

From Fig. 7, 8, 9 and Table I are observed as follows:

- Line to 220 kV-50Hz:

 - If the FG is connected to the mains earth stations at the two ends of the line, X_o and R_o decrease with increasing length of the line up to the lower limit corresponding to the case of wire ground potential. Considering the potential of FG earth we make an error in the calculation of X_o and R_o increasing with decreasing length of the line and increases earth resistance of the supports. For example $L = 5 \text{ km}$ and R_p equal to 10, 20 and 100 Ω is make errors, respectively, - 5.0%, -5.9% and - 7.3% on the X_o and -4.0%, -4.5% -5.6% on R_o . For $L = 25 \text{ km}$ errors are already lower than $1 \div 2\%$.
 - If the FG are not connected to mains earth of the stations, while the X_o decreases with increasing length of the line, R_o increases (Fig. 8), being weaker the ground connection of the cable.

Considering the FG at ground potential are committed errors percentages higher than in the case of FG connected to the mains earth substation.

For $L = 10$ km and R_p equal to 10, 20 and 100 Ω will have errors respectively -7.5%, -11% and -19% on the X_0 .

Always for short lines (5-10 km), for values of R_p medium - low (10-20 Ω), the maximum error of R_0 is 18 to 19%, s committing more errors for values R_p elevated.

- If the FG is high resistance and is connected the land substation, the errors made on X_0 , considering the FG to ground potential are practically negligible, less than 1%. The errors of R_0 is a few percent for values of R_p Medium - Low; become rather high ($\geq 20\%$) to high R_p .

- Line to 400 kV-50 Hz:

Equipped with two FG Al - Ac connected to the earth stations with $R_{S1} = R_{S2} = 0.5 \Omega$: X_0 and R_0 decrease with increasing the length of the line. Considering the FG ground potential, the errors made on X_0 for cable lengths up to 10 km and $R_p = 10 \Omega$ and 20 Ω , are appreciable: -5% and -10%. Become lower than the $2 \div 3\%$ for $L \geq 25$ km. The errors made on R_0 are instead of a few percent more than those committed on the X_0 , however, are reduced to values less than 3% for $L \geq 10$ km.

If FG is isolated from earth station, errors that are committed considering them to ground potential are modeled on the trends shown for the line to 220 kV.

IV. CONCLUSIONS

The work proposes some formulas for better evaluation zero sequence impedance overhead electrical lines equipped with one or two FG. The formulas take into account: the average value of the resistances of the earth of support, resistors to ground substations two ends of the line, the connection or less of FG to the ski ground stations and supports, the possible cutting of FG in some support or absence of FG in some sections of the line.

Considering the FG to ground potential is commit errors in the calculation of R_0 and X_0 that reach only important for short lines built on soils with a high resistivity, equipped with wires guard of low resistance, and especially in the case in which these are not connected to mains earth stations.

The calculation method illustrated can easily be extended to the case of cable lines.

REFERENCES

- [1] A. Paolucci: Lessons of electrical, first Part, CLEUP Publisher, March 1997.
- [2] P.Nefzger, J.F. Nolasco, U. Kaintzyk, F.Kiessling: Overhead Power Lines, Springer, 2003.
- [3] F. Iliceto, FM Gatta, S. Lauria, GO-Dokyi "Three-Phase and Single-Phase Electrification in Developing Countries Using the Insulated Shield Wires of HV lines Energized at MV "- CIRED art. 5/10, Session of 1999.

- [4] FM Gatta, F. Iliceto-"Calculation of Current Flow in Grounding Systems of substations and HV Line Towers, in Line Shield Wires and Cable Sheaths during Earth Faults "- ETEP, Vol.8, No.2, March / April 1998.
- [5] R. Benato, L. Caciolli: "Sequence impedances of insulated cables: Measurements versus computations ", IEEE PES T & D Conference 2012, Orlando, Florida,.
- [6] IEC 60909-2: Short-circuit in three-phase ac systems. Part 2: Data of electrical equipment for short circuit current calculations. Edition 2008.
- [7] R.Benato, L. Caciolli, and E. Zaccone: Sequence impedance computation by means of Multiconductor cell analysis. 8th International Conference on Insulated Power Cables, 2011.
- [8] L.Fellin, R. Benato: Electrical Systems, UTET Technical Sciences, 2010, ISBN 978-88-980618-9.