

# Fuzzy Logic PID Control of Automatic Voltage Regulator System

Aye Aye Mon

**Abstract**—The application of a simple microcontroller to deal with a three variable input and a single output fuzzy logic controller, with Proportional – Integral – Derivative (PID) response control built-in has been tested for an automatic voltage regulator. The fuzzifiers are based on fixed range of the variables of output voltage. The control output is used to control the wiper motor of the auto transformer to adjust the voltage, using fuzzy logic principles, so that the voltage is stabilized. In this report, the author will demonstrate how fuzzy logic might provide elegant and efficient solutions in the design of multivariable control based on experimental results rather than on mathematical models.

**Keywords**—Fuzzy logic system, PID Controller, control systems, controlled A V R.

## I. INTRODUCTION

IN lieu of the advances in power electronics and microprocessors, digitally controlled induction motor drives have become increasingly popular. In many industrial drives advanced digital control strategies for the control of field-oriented induction motor drives with a conventional speed PID controller have gained the widest acceptance in high performance AC servo systems, if the load changes are small and the operating conditions do not force the system too far away from the linear equilibrium point. However, in certain applications, such as steel mills, paper mills, robotics, machine tools, the drive operates under a wide range of load change characteristics and the system parameters vary substantially [1-3]. To overcome this drawback, the control algorithm should include a complicated computation process to eliminate the variations in the load disturbance and systems parameters and also obtain high performance AC system. However, the control algorithms applicable to these systems have become increasingly more complicated, requiring extensive computations for real-time implementation. In recent years, Artificial Neural Network intelligent (ANN) and Fuzzy Logic Controllers (FLC) have gained great important and proved their dexterity of many respects [4, 5].

On the other hand, FLC has been implemented on many platforms such as digital signal processor (DSP), PC or off the self microcontroller. These platforms have many advantage and disadvantages.

The FLC developed on DSP or PC can quickly process fuzzy computation to generate control efforts, but the physical size of the system may too big and quite expensive for a small DC motor application.

Fuzzy logic does not replace conventional control techniques, but provides a solution where conventional methods are not satisfactory. When a present control solution actually exists, replacement of a fuzzy logic may not be necessary. But this is not often true. An alternative solution by Fuzzy logic may be better.

It all depends on how the system under control is known to us in its parameters, variables and relationships of control. If determined values of such variables are not existing, then fuzzy logic based classification of the variables provides a solution which may be better than a method of control using assumed relationship. In this paper, fuzzy logic PID control of Automatic Voltage Regulator is constructed with fuzzy logic and its performances are evaluated.

## II. DESIGN CONSIDERATION

### A. Hardware Implementation

The circuit shown in Fig. 1 employs variable auto transformer. A DC motor is used for moving wiper. The centre tap 12V-0-12V transformer is used for logic circuit and motor power supply. For sensor voltage, 12V supply from auto transformer is rectified and applied to ADC input of PIC microcontroller. A preset R22 (10k) is adjusted to set output voltage of the stabilizer. The input voltage range of the stabilizer is 150V~ 250V. Thus, the specification is:  $V_o = 220V \pm 1V$  if  $150 > V_{in} < 250V$ . The logic circuits are supplied with a constant 5V supply, obtained from a regulator IC7805, fed from 15V unregulated DC. Diodes D3 and D4 rectified the AC input voltage and capacitor C6 smoothes the rectified dc voltage.

The microchip PIC18F452 is a high performance 8 bit microcontroller with flash EPROM built-in for 256 bite [6]. It is used for this fuzzy logic implementation through a software program (as described in section 4). The output voltage signal level is to be input to the microcontroller. The ADC module contained in the microcontroller is used to convert the voltage levels to digital value.

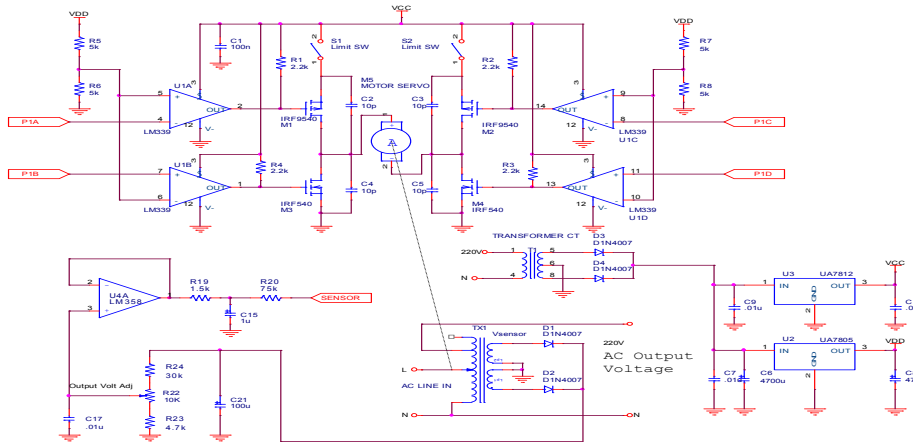

Fig. 1 Control circuit diagram of the fuzzy voltage regulator

With a 10-bit ADC over the full range of mains voltage (0~300V) scaled to 0 to 5V. The resolution is 300/1024 or 0.3V. This is too high a resolution called for.

The output voltage for the DC motor is rule-based. The rules logic is built into the software developed. The motor is driven by using full bridge configuration. The full bridge is designed with MOSFET power transistors. The drive signal for wiper dc motor is generated by the PWM (pulse width modulation) module contained in the microcontroller.

The drive signals are obtained from CCP1 and CCP2 output pin of the microcontroller. The voltage comparator translates the level of digital voltage to the levels required to drive the MOSFETS.

The microcontrollers produce 0V for logic 0 and 5V for logic 1. MOSFETS require 0V for (channel FET) turn off and 12V for turn on. The comparator LM339 convert the logic level to the level required to drive MOSFETS.

**B. DC Motor Control**

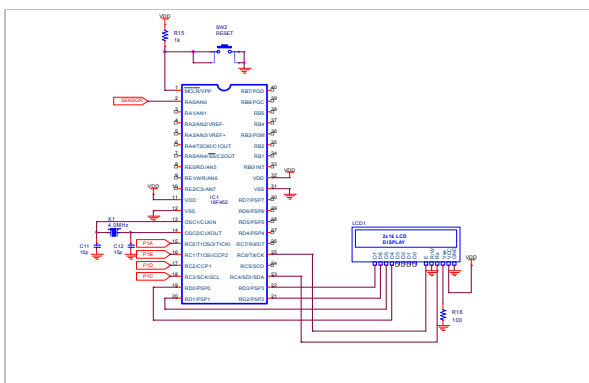

Fig. 2 Control circuit diagram of the fuzzy voltage regulator

The Capture, Compare, PWM (CCP) of the PIC18F452 is used to control the wiper position control DC motor. For bidirectional control, two CCP modules (CCP1 and CCP2) are used. Using two CCP modules allow easy interfacing to a full

bridge configuration for bidirectional brushed DC motor control (BDC)

**C. Bidirectional Brushed DC Motor Control**

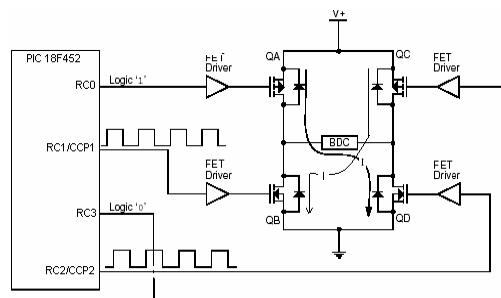

Fig. 3 Full-bridge forward and reverse current flow diagram

PIC18F452 microcontroller contains two CCP modules. CCP1 is used for forward direction and CCP2 is used for reverse direction

**III. SOFTWARE IMPLEMENTATION (FUZZY LOGIC)**

In this research, fuzzy logic is used to control the DC motor. The DC motor controls the position of the wiper which slides on an auto-transformer. With fuzzy logic, output voltage is stabilized while variation of the input range is 150V to 250V.

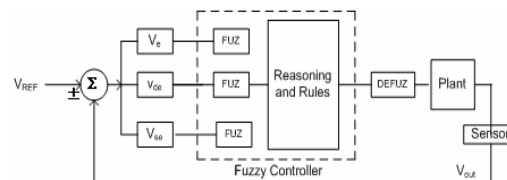

Fig. 4 The fuzzy logic PID controller used for AV regulator

### A. Fuzzy Logic Implementation on Embedded Microcomputers

Fuzzy logic operators provide formal method of manipulating linguistic variable. Linguistic variables are non-precise variables that often convey a surprising amount of information [7].

The linguistic variables so common in everyday speech convey information about an object under observation. Linguistic variables in a computer require a formal way of describing a linguistic variable in crisp terms the computer can deal with. Figure 5 shows the relations between measured error voltage and the linguistic term large negative and large positive.

To add the linguistic variable large negative to a computer program running in an embedded controller, translation the graphical representation into meaningful code is needed. The following C code fragment gives one example of how to do this. The function error- Large Negative ( ) returns a degree of membership, scaled between 0 and 255, indicating the degree to which a given error voltage can be large negative. This type of simple calculation is the first tool required for calculations of fuzzy logic operations.

```

Char      Error-L Negative ( int Ve )
{
    if ( Ve < -10)
        return (255);
    else
        {if ( Ve < 0)
            return (-Ve × 51);
        else
            return (0);
        }
}

```

The following figure show the relationship of other linguistics variables used in fuzzy logic controlled voltage regulator.

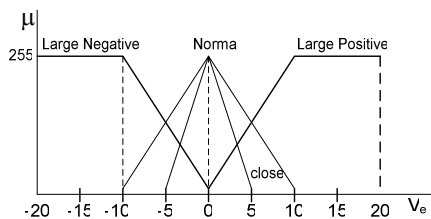

Fig. 5 The relationship between linguistics variable and error voltage

### B. Fuzzy Rules

Instead of using mathematical formula a Fuzzy Logic control uses fuzzy rules to make a decision and generate the control effort. The rules are in the form of IF-THEN statements. For example, If the error voltage ( $V_e$ ) is equal to Large Positive THEN change in the armature voltage is Large

Negative. The matters in defining rules are how many rules should be used and how to determine the relation in IF-THEN statements. Actually, the solutions are based on the experience of a designer or the previous knowledge of the system. The critical point is if there is not sufficient knowledge applied in the design, the result could be drastically bad. In this paper, the following IF-THEN rules are used to control the armature voltage of the motor.

- 1 If error voltage ( $V_e$ ) is Large Negative then the armature voltage is Large Positive (LP).
- 2 If error voltage ( $V_e$ ) is Large Positive then the armature voltage is Large Negative (LN).
- 3 If error voltage ( $V_e$ ) is normal and change of error voltage ( $V_{de}$ ) is Positive then the armature voltage (Vout) is Small Negative (SN).
- 4 If error voltage ( $V_e$ ) is normal and change of error voltage ( $V_{de}$ ) is Negative then the armature voltage (Vout) is Small Positive (SP).
- 5 If error voltage ( $V_e$ ) is close and sum of error voltage ( $V_{se}$ ) is Large Positive then the armature voltage (Vout) is Small Negative (SN).
- 6 If error voltage ( $V_e$ ) is close and sum of error voltage ( $V_{se}$ ) is Large Negative then the armature voltage (Vout) is Small Positive (SP).

### C. Centroid Calculation Defuzzification Method

The result of the defuzzification has to be a numeric value which determines the duty factor of the PWM signal used to drive the motor. It is obtained by finding the centroid point of the function which is the result of the multiplication of the output membership and output vector  $Y [ ]$ . The general mathematical formula which is used to obtain the centroid point is

$$\text{Output} = \frac{\sum_{i=1}^4 Y[i] \times \text{multifact}[i]}{\sum_{i=1}^4 Y[i]} \quad [1]$$

$Y[i]$  is the  $i^{\text{th}}$  members of the output vector multifact  $[i]$  are the multiplying coefficients of the output membership function.

Fig. 6 shows a graphical representation of the output membership used in this application with the coefficients  $[-256 \ 128 \ 255]$ .

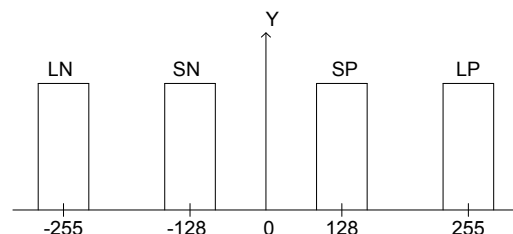

Fig. 6 Output Membership Function

IV. FIRMWARE DESCRIPTION

A high level overview of fuzzy PID voltage stabilizer is shown in Fig. 7 through Fig. 8. Before entering the main control loop firmware initialize itself. Variables are cleared and timer1 and timer2 are cleared.

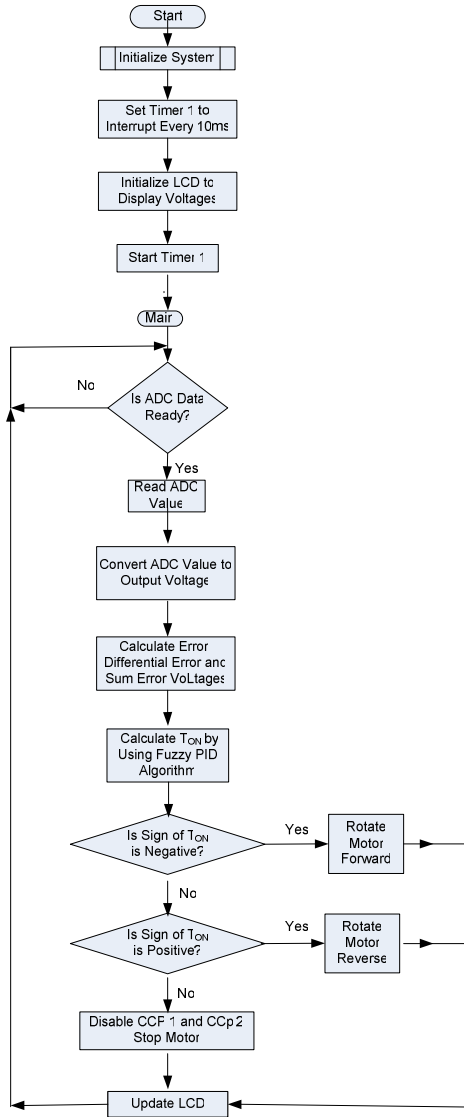

Fig. 7 Fuzzy AVR FIRMWARE (Main Routine)

motor is driven in reverse direction. Motor speed is directly proportional to the magnitude of  $T_{ON}$ . If the value of the  $T_{ON}$  is zero, NO drive power is applied to the wiper motor.

Timer 1 generates interrupt in every 10ms. The interrupt signal from the timer 1 causes AD conversion started. The ADC value is proportional to the output voltage and the main routine calculated output voltage based on the AD value.

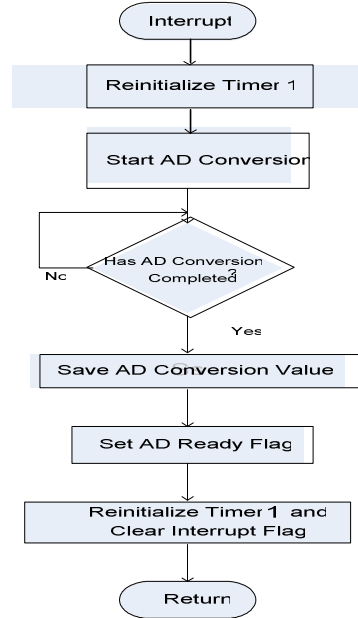

Fig. 8 Fuzzy AVR FIRMWARE (Interrupt Routine)

V. TEST AND RESULT



Fig. 9 A photo of constructed AVR system

The Liquid Crystal Display is initialized. It is used to display output voltage, differential error voltage, error voltage and sum error voltage. This information is used to tune fuzzy rules.

The main loop is responsible for updating ADC value and calculating output voltage, differential error voltage, error voltage and sum error voltage. These values are shown on LCD. Using these variables, on period ( $T_{ON}$ ) is calculated. The calculation is performed using fuzzy PID algorithm.

A wiper motor is driven in accordance with calculated  $T_{ON}$  value. If the sign of the  $T_{ON}$  is negative the wiper motor is driven forward. If the sign of the  $T_{ON}$  is positive the wiper

The experimental layout for the real time test of fuzzy voltage controller is shown in Fig. 9. Fig. 10 shows the real time results with a step input voltage change. One can observe that a fairly good approximation to the reference a little adjustment was made for the value of sum error. There are some discrepancies in the rise and fall times. The results show nevertheless that the implementation of the fuzzy logic algorithm in a 2 low-cost microcontroller can be successfully

applied to control test which require sample time not less than 50 microseconds.

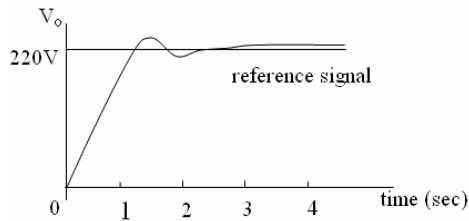

Fig. 10 The approximate response of the constructed fuzzy stabilizer

## VI. CONCLUSION

This paper has demonstrated the implementation of a FLC for the control of fluctuated AC line to a consumer home. The PID - FLC is easy to implement and require a small amount of expensive components in compact size. The controller showed good ratification performance between 150V and 250V input and provide a stable output. The test result shown that the output transient voltage last only 2 seconds and a stable output are established.

## REFERENCES

- [1] B.J. Chalmers, "Influence of saturation in brushless permanent-magnet motor drives," IEE Proc. B, Electr. Power Appl., vol. 139, no. 1, pp.51-52, 1992.
- [2] C. T. Johnson and R.d. Lorenz, "Experimental identification of friction and its compensation in precise, position controlled mechanisms," IEEE Trans. Ind. Applicat., vol.28, no. 6,pp. 1392-1398,1992.
- [3] C.Canudas, K. J. Astrom, and K. Braun, "Adaptive friction compensation in DC-motor drives," IEEE J. Robot., Automat., vol. RA-3, no. 6,pp. 681-685,1987.
- [4] M.A. Wishart and R.G. Harley. Identification and control of induction machines using artificial neural networks. IEEE Trans. Ind. Applicat., vol.31,pp.612-619, 1995.
- [5] Y.S. Kung, C.M. Liaw and M.S. Ouyang. Adaptive speed control for induction motor drives using neural networks. IEEE Trans. Ind. Electron. Vol.42, 1,pp.25-32, 1995.
- [6] Microchip. 2001. PIC18F452 Data Sheet. Microchip Technology Inc. January 2006. <http://www.microchip.com>.
- [7] H. Rongen, "Introduction to Microprocessors and Microcontrollers" Forschungszentrum Julich, Germany 2000.