

# Increasing Convergence Rate of a Fractionally-Spaced Channel Equalizer

Waseem Khan

**Abstract**—In this paper a technique for increasing the convergence rate of fractionally spaced channel equalizer is proposed. Instead of symbol-spaced updating of the equalizer filter, a mechanism has been devised to update the filter at a higher rate. This ensures convergence of the equalizer filter at a higher rate and therefore less time-consuming. The proposed technique has been simulated and tested for two-ray modeled channels with various delay spreads. These channels include minimum-phase and non-minimum-phase channels. Simulation results suggest that that proposed technique outperforms the conventional technique of symbol-spaced updating of equalizer filter.

**Keywords**—Channel equalization, Fractionally-spaced equalizer

## I. INTRODUCTION

CHANNEL equalization has been an area of research for long because of its importance in reducing the information corruption at the receiver side of a wireless communication system. In digital systems, channel equalizers can be broadly classified as symbol-spaced and fractionally-spaced equalizers (FSE). Symbol-spaced equalizers (SSE) take one sample per symbol as input while the equalizers of the other class take 2-8 samples per symbol as input. The previous research [1-3] demonstrates that FSE's are more efficient and effective than SSE's. Due to excess bandwidth of Nyquist pulse, usually employed for baseband pulse-shaping, symbol-spaced sampling of receiver-filter-output cause's aliasing and thus SSE gives sub-optimal results while fractionally spaced sampling ensures protection from aliasing. But in both the techniques the update rate of the equalizer filter is still symbol-spaced. Owing to this fact, the convergence rates of the two techniques of equalization are not much different. Actually the duration between two successive symbol times is just wasted and contributes none towards the training of the equalizer filter. If this duration, is utilized, the convergence rate of the equalizer will certainly enhance by many times. The technique presented here is based on this concept, to ensure fast convergence of equalizer. This technique has been developed for data-aided training of equalizer filter.

W. Khan is Assistant Professor at Air University, PAF Complex, E-9, Islamabad, (Phone: +923335531093; e-mail: waseem.khan@mail.au.edu.pk).

## II. SYSTEM DESCRIPTION

### A. Typical System Model with Equalizer

A typical communication system, using Binary Phase Shift Keying (BPSK) as underlying modulation scheme, with equalizer can be modeled as in Fig 1, where  $d_k[-1,+1]$  are data symbols. These symbols are pulse-shaped by a Root Raised Cosine (RRC) filter. If  $f(t)$  is the impulse response of the filter, output  $p(t)$  of the filter, can be expressed as

$$p(t) = \sum_k d_k f(t - kT) \quad (1)$$

where  $T$  is symbol duration. The channel is modeled as an FIR filter with impulse response  $h(t)$  whose output is coherently demodulated and filtered to get baseband signal  $r(t)$  at receiver. Assuming that carrier synchronization has been acquired at the receiver, output of the receive filter is given by

$$r(t) = f(t) * \left[ h(t) * \sum_k d_k f(t - kT) \right] \quad (2)$$

where  $*$  represents a convolution operation and the receive-filter is matched with the pulse shaping filter at the transmitter. Here the ideally expected baseband signal  $r'(t)$  can be estimated by assuming the channel as ideal i.e. by replacing  $h(t)$  in (2) by  $\delta(t)$ , i.e.

$$r'(t) = f(t) * \left[ \sum_k d_k f(t - kT) \right] \quad (3)$$

In case of an ideal channel, the expected signal at the output of the receive-filter is given by (3). If the channel is a non-ideal one, the expected and received signals will not be identical and their difference, called as error, is to be minimized using an equalizer. To deal with discrete data, sampled versions of the two signals, represented by  $r[n]$  and  $r'[n]$  respectively, may be used and there difference is  $e[n]$ .

$$e[n] = r'[n] - r[n] \quad (4)$$

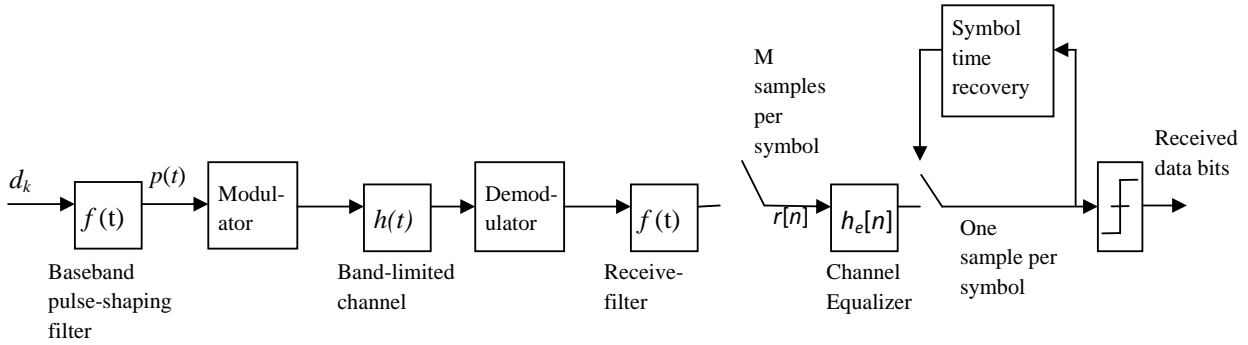

Fig. 1 Model of a BPSK communication system with equalizer

**B. Equalizer Updating Mechanism**

Output of the receive-filter is generally down-sampled to get reasonable number of samples per symbol. Fig. 2 shows the conventional strategy for data-aided training of equalizer filter, where the filter takes M samples per symbol. This technique assumes that the expected incoming samples are known only at symbol times; therefore error is calculated only at symbol times. This in turn dictates to update the equalizer filter not more than once the symbol duration. And if it is desired to update the equalizer filter more than once the symbol duration, there should be a mechanism to calculate error more frequently.

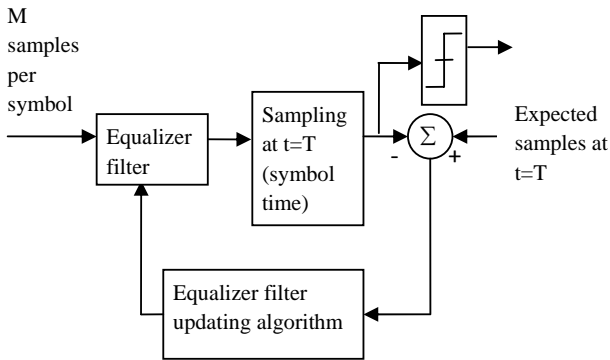

Fig. 2 Conventional technique of updating equalizer filter

**III. PROPOSED TECHNIQUE FOR UPDATING EQUALIZER FILTER**

The technique proposed in this paper for updating fractionally spaced equalizer filter is depicted in Fig 3. This technique builds an expected baseband signal by passing the known data pulses through a baseband pulse shaping filter  $f'(t)$ . The expected baseband signal is the same that would be received if the channel would be ideal (i.e.  $h(t) = \delta(t)$ ). In case of an ideal channel the received signal would be expressed by (3), which can be re-arranged as follows

$$r'(t) = f'(t) * \left[ \sum_k d_k \delta(t - kT) \right] \tag{5}$$

where  $f'(t) = f(t) * f(t)$ . As these filters are implemented in digital, therefore equivalently following may be written

$$r'[n] = f'[n] * \left[ \sum_k d_k \delta(n - kN) \right] \tag{6}$$

where  $N=TF_s$  and  $F_s$  is sampling frequency. As the expected baseband signal here, is known at every sample, therefore error can be calculated at every sample, which enables us to update the equalizer filter at every sample. Error is again given by (4) but here it is calculated at every sample. Due to updating the equalizer filter at every sample, it converges faster than it does in an equalizer employing symbol-spaced updating of the filter. This will be demonstrated by simulation results.

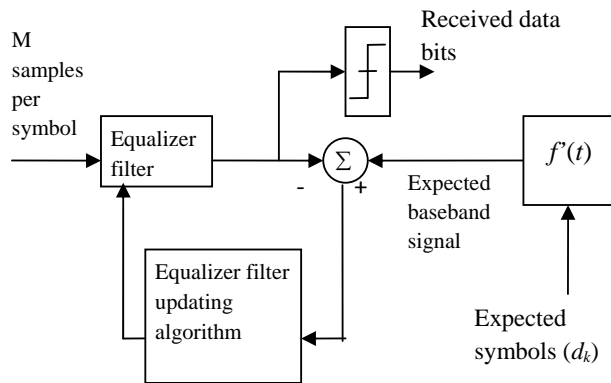

Fig. 3 Proposed technique of updating equalizer filter

#### IV. SIMULATION

##### A. System Parameters

The above discussed communication system, has been simulated in Matlab, employing both the techniques of updating equalizer filter. The system parameters for simulation have been taken as under.

Modulation:	BPSK
Carrier frequency:	16 MHz
Bit rate:	2 Mb/second
Sampling frequency:	64 MHz
Equalizer filter input rate:	8 samples/symbol
Equalizer updating algorithm:	LMS
Equalizer filter length:	21
Baseband pulse:	Raised cosine pulse with support time equivalent to 5 symbols duration and roll-off factor 0.5

##### B. Channel Model

For simulation purpose a 2-ray model of the channel has been used. In general discrete-time impulse response of such a channel can be represented by

$$h[n] = A\delta[n] + B\delta[n-\tau] \quad (7)$$

where  $\tau$  is delay spread for the second ray and A and B are gain factors for first and second rays respectively. Following three channels have been simulated with different values of these parameters.

Channel 1: A=0.9, B = 0.4,  $\tau = 16$

Channel 2: A=0.9, B = 0.7,  $\tau = 32$

Channel 3: A=0.7, B = 0.9,  $\tau = 16$

Here  $\tau = 16$  and  $\tau = 32$  are equivalent to delay spread of  $T/2$  and  $T$  seconds respectively. These settings make the channel a frequency selective fading channel. It is notable here that channel 3 is a non-minimal phase channel which is difficult to equalize due to its zeros outside unit circle in z-plane.

##### C. Results

Figures 4-6 shows normalized error square at the output of equalizer filter versus number of bits, for the three channels described in IV, employing the conventional and proposed techniques of updating equalizer filter. It is clear from the results that the proposed technique promises error decay at a rate higher than the conventional technique. Hence the number of training symbols required for training of the equalizer filter

has been considerably reduced with the proposed strategy. It is clear that channel 2 corrupts the signal more than channel 1 due to increased delay spread. Moreover, channel 3 behaves worse than channel 1 because the former one is a non-minimal phase channel.

#### V. CONCLUSIONS

The simulation results clearly exhibit that the proposed technique converges faster than the conventional technique. It is note worthy here that the proposed technique outperforms the conventional one for channel 3 as well, which is a non-minimal phase channel. The technique, proposed here, has been developed for training mode only. But it can be extended to decision directed mode. In this mode, the expected samples will be calculated using the past decided symbols. However, the proposed strategy, even in its present form, can be useful for burst mode communication where the channel characteristics remain the same in a burst-duration and hence decision directed mode of equalization is not needed. Further, the proposed technique ensures the convergence of the channel equalizer in a very short time leaving an ample portion of the burst duration for the useful data.

#### ACKNOWLEDGMENT

W. Khan acknowledges the efforts of Dr. Ijaz Mansoor Qureshi who reviewed this paper and suggested important modifications in the paper outline.

#### REFERENCES

- [1] Benedetto, S., Biglieri, E. and Castellani V. "Digital Transmission Theory", Prentice Hall, 1987
- [2] Qureshi, S. U. H and Forney, G. D., "Performance Properties of a T/2 Equalizer", IEEE Globecom, pp. 11.1.1-11.1.4, Los Angeles, CA, December 1977.
- [3] Gitlin, R. D., and Weinstein, S. B., "Fractionally Spaced Equalization: An Improved Digital Transversal Filter", Bell Systems Technical Journal, Vol. 60, pp. 275-296, February 1981.

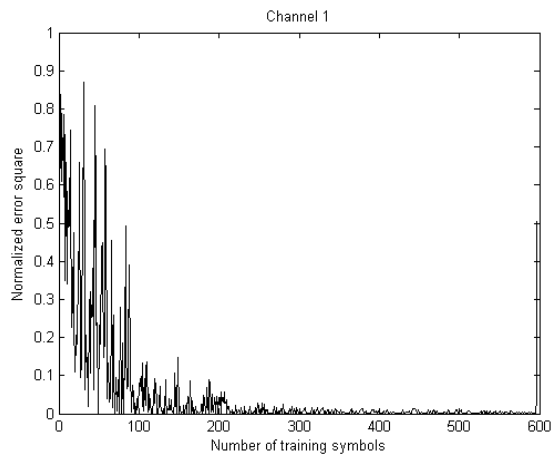

(a)

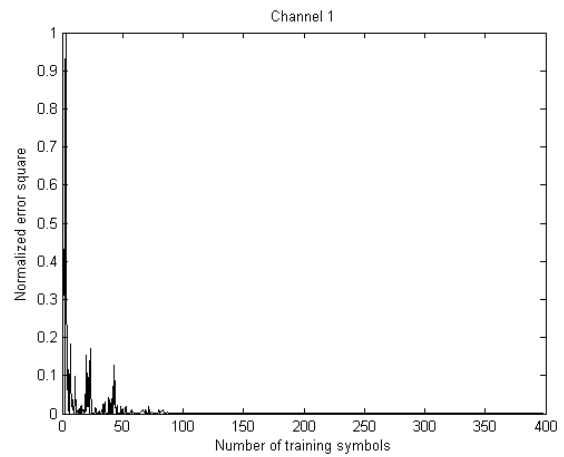

(b)

Fig. 4 Normalized error square for channel 1 employing (a) conventional and (b) proposed technique

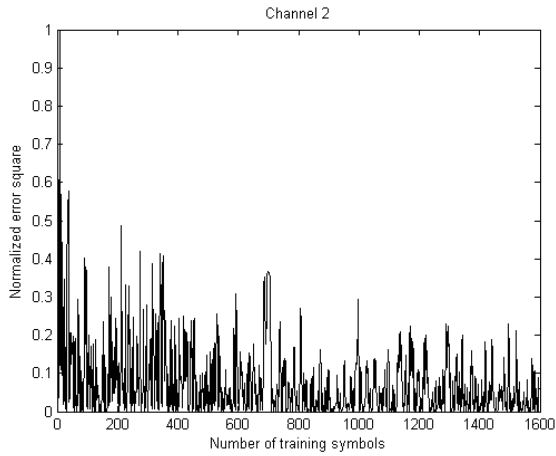

(a)

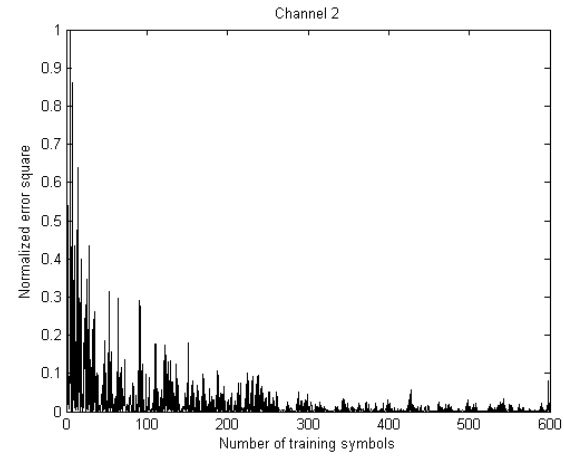

(b)

Fig. 5 Normalized error square for channel 2 employing (a) conventional and (b) proposed technique

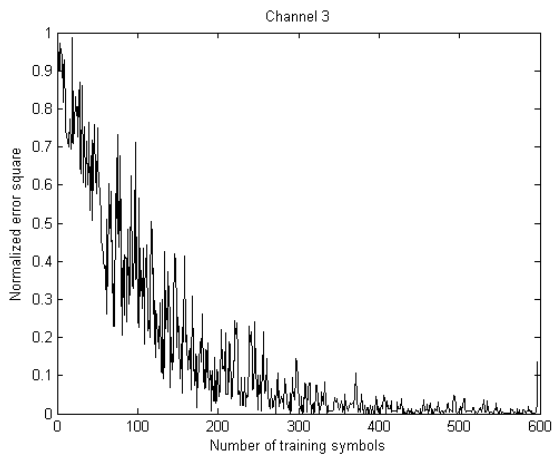

(a)

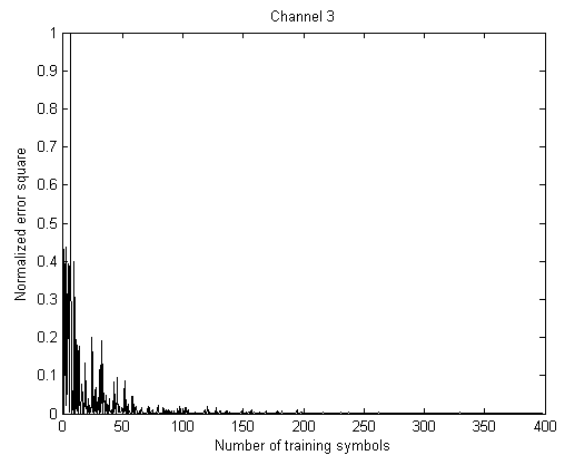

(b)

Fig. 6 Normalized error square for channel 3 employing (a) conventional and (b) proposed technique