

Rotor Bearing System Analysis Using the Transfer Matrix Method with Thickness Assumption of Disk and Bearing

Omid Ghasemalizadeh, Mohammad Reza Mirzaee, Hossein Sadeghi, and Mohammad Taghi Ahmadian

Abstract—There are lots of different ways to find the natural frequencies of a rotating system. One of the most effective methods which is used because of its precision and correctness is the application of the transfer matrix. By use of this method the entire continuous system is subdivided and the corresponding differential equation can be stated in matrix form. So to analyze shaft that is this paper issue the rotor is divided as several elements along the shaft which each one has its own mass and moment of inertia, which this work would create possibility of defining the named matrix. By Choosing more elements number, the size of matrix would become larger and as a result more accurate answers would be earned. In this paper the dynamics of a rotor-bearing system is analyzed, considering the gyroscopic effect. To increase the accuracy of modeling the thickness of the disk and bearings is also taken into account which would cause more complicated matrix to be solved. Entering these parameters to our modeling would change the results completely that these differences are shown in the results. As said upper, to define transfer matrix to reach the natural frequencies of probed system, introducing some elements would be one of the requirements. For the boundary condition of these elements, bearings at the end of the shaft are modeled as equivalent spring and dampers for the discretized system. Also, continuous model is used for the shaft in the system. By above considerations and using transfer matrix, exact results are taken from the calculations. Results Show that, by increasing thickness of the bearing the amplitude of vibration would decrease, but obviously the stiffness of the shaft and the natural frequencies of the system would accompany growth. Consequently it is easily understood that ignoring the influences of bearing and disk thicknesses would results not real answers.

Keywords—Rotor System, Disk and Bearing Thickness, Transfer Matrix, Amplitude.

I. INTRODUCTION

ROTARY machines such as turbine, generators, and electrical motors are one the most important parts of industries esearches and rotating shafts are the most effective elements of these machines. Role of rotary shafts are in power transmission. These shafts would bear different parts such as bearings, disks, gears and etc on them. Various methods have

Manuscript received March 26, 2008. This work was supported in part by the Department of Mechanical Engineering at Sharif university of Technology.

Omid Ghasemalizadeh is with Sharif University of Technology (corresponding author alizadeh.omid@gmail.com).

been used to analyze rotary systems which each one ahs its own advantages. The Jeffcott model¹ for rotors assumes a massless shaft having a rigid rotor on it. The transfer matrix is a useful method for analyzing elastic structures². The transfer matrices of many standard parts are given in handbooks. Sometimes, however, the required transfer matrix is not catalogued. It is often possible to find the transfer matrix by using simple dynamic equations or by using results that are tabulated in engineering handbooks. The merit of transfer matrix method lies in the fact that the dynamics of complicated systems can be simplified into a system of algebraic equations. Prohl³ in 1945 suggested the transfer matrix method. lund and orcutt⁴ in 1967 used this method with the continuous model for shaft and unbalance in disk taken into account. Kirk and Bansal⁵ in 1975 used the transfer matrix method for calculating damped natural frequencies. Kang and Tan⁶ in 1998 investigated discontinuity in shafts using this method. As said before in this paper a Continuous model is used for the shaft and the gyroscopic effect is also taken into account. The most important and effective assumptions in this research are investigating the effects of bearings and disk thicknesses exactly which would have great influences in accuracy of our answers. Figures in results for amplitude would prove the thicknesses impacts. So the citation of our calculations would be confirmed extensively. The key feature of this study is that the thickness of the disk is considered and the width of supporting end bearings is also modeled.

II. MODELING PRINCIPLES

In this analysis the vibration amplitude is assumed to be small. The Timoshenko beam theory is used for expressing the dynamics of the shaft. This theory assumes a constant transversal shear strain at the direction of thickness of the beam. To determine the shear forces, a correction factor (K) is used. Each section of the shaft is assumed to have two translational and two rotational motions about the perpendicular axes.

In this paper the fluid film journal bearing is considered for both ends of the shaft. Since the bearings have much more damped behavior than the shaft, this effect is neglected for the shaft and the motion of shaft is assumed to be undamped. The

bearings are modeled as equivalent spring and dampers which are applied as boundary conditions to the discretized system.

The transfer matrix of the shaft, disk, and bearing are obtained assuming that the gyroscopic effect is present and the disk has a finite thickness.

A. Shaft Transfer Matrix

An element of the deflected shaft in the yz and xz planes are depicted in Figs. 1 and 2, respectively. The subscripts l and r correspond to left and right sides of the element. The local coordinate system (x_1, y_1, z_1) sticks to the shaft having its z_1 axis in the axial direction of the shaft.

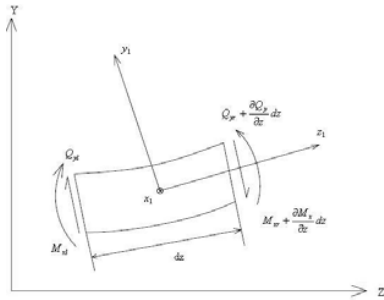

Fig. 1 Element of shaft in yz plane

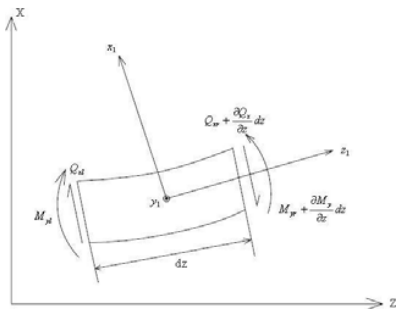

Fig. 2 Element of shaft in xz plane

The resultant moment vectors for the element is:

$$\sum \mathbf{M} = \begin{bmatrix} -\frac{\partial M_x}{\partial z} + Q_y \\ \frac{\partial M_y}{\partial z} - Q_x \\ 0 \end{bmatrix}$$

and the angular momentum vector is

$$\bar{\mathbf{H}} = \begin{bmatrix} -\rho I_x \frac{\partial \theta}{\partial t} \theta_x \\ \rho I_y \frac{\partial \theta}{\partial t} \theta_y \\ \rho I_z \omega \end{bmatrix}$$

where ω is the spin velocity and I_x and I_y are the second moments of area which are assumed to be equal. Newton's second law for rotation is expressed as: [7]

$$\sum \mathbf{M} = \dot{\bar{\mathbf{H}}} + \boldsymbol{\Omega} \times \bar{\mathbf{H}} \quad (3)$$

where

$$\boldsymbol{\Omega} = \left\{ -\frac{\partial \theta_x}{\partial z} \quad \frac{\partial \theta_y}{\partial z} \quad \omega \right\}^T \quad (4)$$

is the angular velocity of the local coordinate system. substituting eqs. 1,2 and 4 into equ 3 results in

$$-\frac{\partial M_x}{\partial z} + Q_y = -\rho I_x \frac{\partial^2 \theta_x}{\partial t^2} + \frac{\partial \theta_y}{\partial t} \rho I_z \omega \quad (5)$$

$$\frac{\partial M_y}{\partial z} - Q_x = \rho I_x \frac{\partial^2 \theta_y}{\partial t^2} \theta_y + \frac{\partial \theta_x}{\partial t} \theta_x \rho I_z \omega$$

the resultant external force vector exerted on the element is

$$\sum \mathbf{F} = \begin{bmatrix} -\frac{\partial Q_x}{\partial z} \\ \frac{\partial Q_y}{\partial z} \\ 0 \end{bmatrix} \quad (6)$$

Applying the Newton's second law to the element results in

$$-\frac{\partial Q_x}{\partial z} = \rho A \frac{\partial^2 x}{\partial t^2}, \quad -\frac{\partial Q_y}{\partial z} = \rho A \frac{\partial^2 y}{\partial t^2} \quad (7)$$

Equations 5 and 7 constitute the partial differential equation of the shaft. The following equations govern the bending moment and shear force in the shaft. [8], [9]

$$M_x = EI_x \frac{\partial \theta_y}{\partial z}, \quad M_y = EI_x \frac{\partial \theta_x}{\partial z} \quad (8)$$

$$Q_x = KAG \left(\theta_y - \frac{\partial x}{\partial z} \right), \quad Q_y = KAG \left(\theta_x - \frac{\partial y}{\partial z} \right)$$

By replacing equ. 8 into eqs. 5 and 7 the governing differential equations of the shaft in xy and yz planes are obtained, which simplifies to:

$$\frac{\partial^4 x}{\partial z^4} - \left(\frac{\rho}{KG} + \frac{\rho}{E} \right) \frac{\partial^4 x}{\partial z^2 \partial t^2} + \frac{\rho^2}{KEG} \frac{\partial^4 x}{\partial t^4} + \frac{\rho A}{EI} \frac{\partial^2 x}{\partial t^2} + \frac{2\rho\omega}{E} \left(\frac{\partial^3 y}{\partial z^2 \partial t} - \frac{\rho}{KG} \frac{\partial^3 y}{\partial t^3} \right) = 0 \quad (9)$$

$$\frac{\partial^4 y}{\partial z^4} - \left(\frac{\rho}{KG} + \frac{\rho}{E} \right) \frac{\partial^4 y}{\partial z^2 \partial t^2} + \frac{\rho^2}{KEG} \frac{\partial^4 y}{\partial t^4} + \frac{\rho A}{EI} \frac{\partial^2 y}{\partial t^2} - \frac{2\rho\omega}{E} \left(\frac{\partial^3 x}{\partial z^2 \partial t} - \frac{\rho}{KG} \frac{\partial^3 x}{\partial t^3} \right) = 0$$

The general solution to these PDEs are in the form of:

$$\begin{aligned} x &= x_c(z) \cos \hat{\Omega} t + x_s(z) \sin \hat{\Omega} t \\ y &= y_c(z) \cos \hat{\Omega} t + y_s(z) \sin \hat{\Omega} t \end{aligned} \quad (10)$$

where $\hat{\Omega}$ is the natural frequency of the system. Substituting equ. 10 into equ. 9 results in four ODEs which require that the factors of *Sin* and *Cos* to be zero in order to have a nontrivial

solution. The solution to the above set of ODE is in the form of:

$$\begin{aligned} x_c &= u_c e^{\lambda z}, x_s = u_s e^{\lambda z} \\ y_c &= v_c e^{\lambda z}, y_s = v_s e^{\lambda z} \end{aligned} \quad (11)$$

By substituting the assumed solution into the four equations that have been created, a set of algebraic equations is obtained which is not stated here for the sake of brevity. In order to have a nontrivial solution the determinant of the coefficient matrix should vanish which results in the following characteristic equation:

$$\begin{aligned} &\begin{pmatrix} -\rho A \Omega^2 K G + \rho^2 \Omega^4 I_x + \rho \Omega^2 I_x \lambda^2 E + 2 \rho^2 \omega \Omega^3 I_x \\ + \rho \Omega^2 I_x \lambda^2 K G + \lambda^4 K G E I_x + 2 \rho \omega \lambda^2 \Omega K G I_x \end{pmatrix}^2 \times \\ &\begin{pmatrix} -\rho A \Omega^2 K G + \rho^2 \Omega^4 I_x + \rho \Omega^2 I_x \lambda^2 E - 2 \rho^2 \omega \Omega^3 I_x \\ + \rho \Omega^2 I_x \lambda^2 K G + \lambda^4 K G E I_x - 2 \rho \omega \lambda^2 \Omega K G I_x \end{pmatrix} = 0 \end{aligned} \quad (12)$$

The above equation has the following eight roots: $\pm \lambda_1, \pm i \lambda_2, \pm \lambda_3, \pm i \lambda_4$, which result the following statements for the four unknowns (u_s, u_c, v_s, v_c)

$$\begin{cases} u_s = v_c, u_c = -v_s, \text{ for } (\pm i \lambda_2, \pm \lambda_1) \\ u_s = -v_c, u_c = v_s, \text{ for } (\pm i \lambda_4, \pm \lambda_3) \end{cases} \quad (13)$$

Using the obtained roots, the displacement amplitudes may be expressed as;

$$\begin{aligned} x_c &= b_1 \cosh(\lambda_1 z) + b_2 \sinh(\lambda_1 z) + b_3 \cos(\lambda_2 z) + b_4 \sin(\lambda_2 z) \\ &\quad + b_5 \cosh(\lambda_3 z) + b_6 \sinh(\lambda_3 z) + b_7 \cos(\lambda_4 z) + b_8 \sin(\lambda_4 z) \\ x_s &= b_9 \cosh(\lambda_1 z) + b_{10} \sinh(\lambda_1 z) + b_{11} \cos(\lambda_2 z) + b_{12} \sin(\lambda_2 z) \\ &\quad + b_{13} \cosh(\lambda_3 z) + b_{14} \sinh(\lambda_3 z) + b_{15} \cos(\lambda_4 z) + b_{16} \sin(\lambda_4 z) \\ y_c &= -b_1 \cosh(\lambda_1 z) - b_2 \sinh(\lambda_1 z) - b_3 \cos(\lambda_2 z) - b_4 \sin(\lambda_2 z) \\ &\quad + b_5 \cosh(\lambda_3 z) + b_6 \sinh(\lambda_3 z) + b_7 \cos(\lambda_4 z) + b_8 \sin(\lambda_4 z) \\ y_s &= b_9 \cosh(\lambda_1 z) + b_{10} \sinh(\lambda_1 z) + b_{11} \cos(\lambda_2 z) + b_{12} \sin(\lambda_2 z) \\ &\quad - b_{13} \cosh(\lambda_3 z) - b_{14} \sinh(\lambda_3 z) - b_{15} \cos(\lambda_4 z) - b_{16} \sin(\lambda_4 z) \end{aligned} \quad (14)$$

All the b_i coefficients in the above equation are collected into the vector \mathbf{B} .

$$\{\mathbf{B}\} = \{b_i\}_{16 \times 1} \quad (15)$$

To obtain the transfer matrix of the shaft it is necessary to express the state vector in one side of the element in terms of the state vector in the other side. The state vector for the shaft is:

$$\mathbf{S} = \{x_c \quad x_s \quad y_c \quad y_s \quad \theta_{xc} \quad \theta_{xs} \quad \theta_{yc} \quad \theta_{ys} \quad M_{xc} \quad M_{xs} \quad M_{yc} \quad M_{ys} \quad Q_{xc} \quad Q_{xs} \quad Q_{yc} \quad Q_{ys}\}^T \quad (16)$$

where s and c indices correspond to the \sin and \cos expressions as stated for x and y in equ. 10.

A vector of position derivatives is also defined as;

$$\mathbf{W} = \{x_c \quad x_c' \quad x_c'' \quad x_c''' \quad x_s \quad x_s' \quad x_s'' \quad x_s''' \quad y_c \quad y_c' \quad y_c'' \quad y_c''' \quad y_s \quad y_s' \quad y_s'' \quad y_s'''}^T \quad (17)$$

At two ends of the element, the above vector is equal to:

$$\begin{aligned} \{\mathbf{W}_{z=0}\} &= [\mathbf{A}_0] \{\mathbf{B}\} \\ \{\mathbf{W}_{z=L}\} &= [\mathbf{A}_L] \{\mathbf{B}\} \end{aligned} \quad (18)$$

where $[\mathbf{A}_0]$ and $[\mathbf{A}_L]$ are given in appendix 1.

By omitting the $\{\mathbf{B}\}$ vector in eqs. 16 we conclude that;

$$\{\mathbf{W}_{z=L}\} = [\mathbf{A}_L][\mathbf{A}_0]^{-1} \{\mathbf{W}_{z=0}\} = [\mathbf{A}] \{\mathbf{W}_{z=0}\} \quad (19)$$

By expanding the components in the \mathbf{W} vector, the relation between \mathbf{W} and \mathbf{S} may be found.

$$\begin{aligned} x &= x, \quad x' = \theta_y - \frac{Q_x}{KAG}, \quad x'' = \frac{M_y}{EI_x} - \frac{1}{KAG} (-\rho A \ddot{x}) \\ x''' &= \frac{1}{EI_x} (Q_x + \rho I_x \ddot{\theta}_y + 2 \rho I_x \omega \dot{\theta}_x) + \frac{\rho}{KG} (\ddot{\theta}_y - \frac{\ddot{Q}_x}{KAG}) \\ y &= y, \quad y' = \theta_x - \frac{Q_y}{KAG}, \quad y'' = \frac{M_x}{EI_x} - \frac{1}{KAG} (-\rho A \ddot{y}) \\ y''' &= \frac{1}{EI_x} (Q_y + \rho I_x \ddot{\theta}_x - 2 \rho I_x \omega \dot{\theta}_y) + \frac{\rho}{KG} (\ddot{\theta}_x - \frac{\ddot{Q}_y}{KAG}) \end{aligned} \quad (20)$$

By collecting the above relations into matrix form, the following relation is resulted

$$\{\mathbf{W}\} = [\mathbf{F}] \{\mathbf{S}\} \quad (21)$$

where $[\mathbf{F}]$ can be calculated simply. Using eqs. 19 and 21 the state vector in one side of the element may be related to that of the other side as follows:

$$\begin{aligned} \{\mathbf{S}_{z=L}\} &= [\mathbf{F}]^{-1} \{\mathbf{W}_{z=L}\} = [\mathbf{F}]^{-1} [\mathbf{A}] \{\mathbf{W}_{z=0}\} \\ &= [\mathbf{F}]^{-1} [\mathbf{A}] [\mathbf{F}] \{\mathbf{S}_{z=0}\} = [\mathbf{T}] \{\mathbf{S}_{z=0}\} \end{aligned} \quad (22)$$

So the transfer matrix of the shaft is obtained from.

$$[\mathbf{T}]_{16 \times 16} = [\mathbf{F}]^{-1} [\mathbf{A}_L][\mathbf{A}_0]^{-1} [\mathbf{F}] \quad (23)$$

B. Disk Transfer Matrix

The disk free body diagram is depicted in Fig. 3.

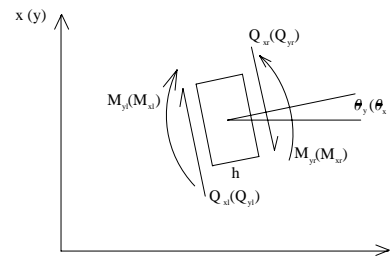

Fig. 3 Free body diagram of disk

Here it is assumed that the disk is nonhomogeneous such that its center of mass is located by a small distance r off the geometric center. It is also assumed that r is such small that its effect on the inertia tensor may be neglected. So the inertia tensor of the disk is written as:

$$\mathbf{I} = \begin{bmatrix} I_d & 0 & 0 \\ 0 & I_d & 0 \\ 0 & 0 & 2I_d \end{bmatrix} \quad (24)$$

Where I_d is the mass moment of inertia of the disk about an axis passing through its center of gravity (CG). Again the Newton's second law is used to obtain the equations of motion for the disk. Application of Newton's second law to translational motion of the disk results in:

$$\frac{\ddot{x}_l + \ddot{x}_r}{2} - r\omega^2 \cos \omega t = Q_{xl} - Q_{xr} \quad (25)$$

$$\frac{\ddot{y}_l + \ddot{y}_r}{2} - r\omega^2 \sin \omega t = Q_{yl} - Q_{yr}$$

Newton's second law in rotational motion is given in equ. 3. The angular momentum of disk is

$$\mathbf{H} = \mathbf{I} \times \boldsymbol{\Omega} \quad (26)$$

where $\boldsymbol{\Omega}$ is the same as than in equ. 4. The obtained angular momentum should be transformed into the global coordinate system using a rotation matrix ($\mathbf{R}(\omega t)$))

$$\Sigma \mathbf{M} = \mathbf{R}(-\omega t) \dot{\mathbf{H}} + \boldsymbol{\Omega} \times (\mathbf{R}(-\omega t) \mathbf{H}) \quad (27)$$

The resultant of moment vectors acting on the disk is:

$$\Sigma \mathbf{M} = \begin{bmatrix} M_{xl} - M_{xr} + \frac{h}{2} \times (Q_{yl} + Q_{yr}) \\ M_{yr} - M_{yl} + \frac{h}{2} \times (Q_{xl} + Q_{xr}) \\ 0 \end{bmatrix} \quad (28)$$

Substituting eqs. 26 and 28 into equ. 27 yields the equation of motion for rotation of the disk. Again by writing the degrees of freedom as in equ. 10, the above governing differential equations are simplified to some algebraic equations. Using the following additional equations;

$$\begin{aligned} \theta_{xr} &= \theta_{xl}, & \theta_{yr} &= \theta_{yl} \\ x_r &= x_l + h\theta_{xl}, & y_r &= y_l + h\theta_{yl} \end{aligned} \quad (29)$$

the state vector at both ends of the disk may now be related and the transfer matrix is obtained.

C. Bearing Transfer Matrix

A linear model is assumed for bearings which uses two equivalent pairs of spring and dampers for each bearing as shown in Fig. 4.

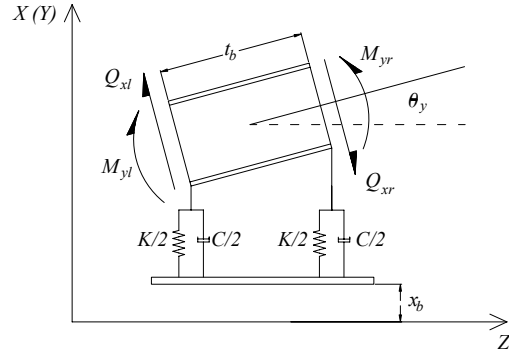

Fig. 4 Bearing model

In this figure t_b represents the length of the shaft that lies in the bearing and x_b or y_b is the foundation displacement. This model assumes that each bearing can withstand moment in addition to transversal load. In a simplified model we assume that the bearing force vector can be written as;

$$\vec{F} = f(x, y)\hat{i} + g(x, y)\hat{j} \quad (30)$$

where

$$\begin{cases} f(x, y) = k_{xx}x + k_{xy}y \\ g(x, y) = k_{yx}x + k_{yy}y \end{cases} \quad (31)$$

the force and moment resultants are as follows;

$$\begin{aligned} \Sigma F_x &= Q_{xl} - Q_{xr} \\ &- \frac{k_{xx}}{2}(x_l - x_b) - \frac{k_{xy}}{2}(y_l - y_b) - \frac{k_{xx}}{2}(x_r - x_b) - \frac{k_{xy}}{2}(y_r - y_b) \\ &- \frac{c_{xx}}{2}(\dot{x}_l - \dot{x}_b) - \frac{c_{xy}}{2}(\dot{y}_l - \dot{y}_b) - \frac{c_{xx}}{2}(\dot{x}_r - \dot{x}_b) - \frac{c_{xy}}{2}(\dot{y}_r - \dot{y}_b) \\ \Sigma F_y &= Q_{yl} - Q_{yr} \\ &- \frac{k_{yy}}{2}(y_l - y_b) - \frac{k_{yx}}{2}(x_l - x_b) - \frac{k_{yy}}{2}(y_r - y_b) - \frac{k_{yx}}{2}(x_r - x_b) \\ &- \frac{c_{yy}}{2}(\dot{y}_l - \dot{y}_b) - \frac{c_{yx}}{2}(\dot{x}_l - \dot{x}_b) - \frac{c_{yy}}{2}(\dot{y}_r - \dot{y}_b) - \frac{c_{yx}}{2}(\dot{x}_r - \dot{x}_b) \\ \Sigma M_y &= M_{yr} - M_{yl} + \frac{k_{xx}}{4}(x_l - x_b)t_b \\ &- \frac{t_b}{2}(Q_{xl} - Q_{xr}) + \frac{k_{xy}}{4}(y_l - y_b)t_b - \frac{k_{xx}}{4}(x_r - x_b)t_b \\ &- \frac{k_{xy}}{4}(y_r - y_b)t_b + \frac{c_{xx}}{4}(\dot{x}_l - \dot{x}_b)t_b + \frac{c_{xy}}{4}(\dot{y}_l - \dot{y}_b)t_b \\ &- \frac{c_{xx}}{4}(\dot{x}_r - \dot{x}_b)t_b - \frac{c_{xy}}{4}(\dot{y}_r - \dot{y}_b)t_b \\ \Sigma M_x &= M_{xl} - M_{xr} - \frac{k_{yy}}{4}(y_l - y_b)t_b \\ &+ \frac{t_b}{2}(Q_{yl} - Q_{yr}) - \frac{k_{yx}}{4}(x_l - x_b)t_b + \frac{k_{yy}}{4}(y_r - y_b)t_b \\ &+ \frac{k_{yx}}{4}(x_r - x_b)t_b - \frac{c_{yy}}{4}(\dot{y}_l - \dot{y}_b)t_b - \frac{c_{yx}}{4}(\dot{x}_l - \dot{x}_b)t_b \\ &+ \frac{c_{yy}}{4}(\dot{y}_r - \dot{y}_b)t_b + \frac{c_{yx}}{4}(\dot{x}_r - \dot{x}_b)t_b \end{aligned} \quad (32)$$

Using the Newton's second law in rotation and translation and by using the following geometrical additional equations;

$$\begin{aligned} \theta_{xr} &= \theta_{xl} = \theta_x, & \theta_{yr} &= \theta_{yl} = \theta_y, \\ x_r &= x_l + t_b \theta_y, & y_r &= y_l + t_b \theta_x \end{aligned} \quad (33)$$

The governing differential equation of the bearing is obtained. Again by assuming harmonic motion for all degrees of freedom (as equ. 10), the governing algebraic equation is obtained which is used to calculate the transfer matrix of the bearing.

To obtain the transfer matrix between two desired points of the system, the transfer matrices of the individual elements located between the points should be multiplied consequently. If the transfer matrix of the whole system is available, applying the boundary conditions on the state vector of both ends will result in a relation among the unknown properties of the system.

III. RESULTS

To investigate the applicability of this method in dynamic analysis of rotor-bearing systems, an example is provided. A shaft carrying several disks is supported on two bearings on both ends as shown in Fig. 5. The required properties are given in the figure.

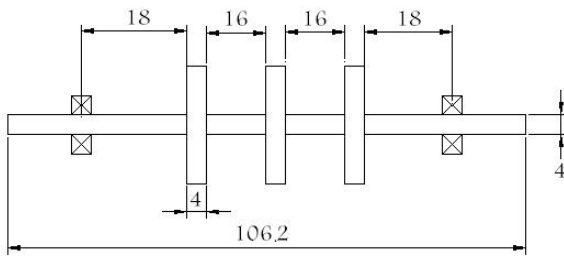

Fig. 5 Schematic figure of a rotor

In this example a flexible shaft is carrying three similar disks and two bearings are supporting the shaft. The parameters of the system and its parts are given in Table I.

TABLE I
PARAMETERS OF THE ROTOR-BEARING SYSTEM

Modulus of elasticity (N/cm^2)	2.07×10^7
Shear modulus (N/cm^2)	1.29×10^7
Density (kg/cm^3)	7.75×10^{-3}
Disc mass (kg)	13.47
Polar moment of inertia ($kg.cm^2$)	1020
Mass moment of inertia ($kg.cm$)	512
Unbalance of disc ($kg.cm$)	0.01347
Shaft diameter (cm)	4

By use of Fig. 5 and Table I informations and also applying transfer matrix different conditions are probed and their results are shown in Figs. 6, 7, and 8.

Three different conditions are as follow:

- Ignoring disk and bearing thickness
- Ignoring bearing thickness and considering it for disk
- Considering thickness for both bearing and disk

For the first one the amplitude-rotational speed curve in Fig. 6 is obtained.

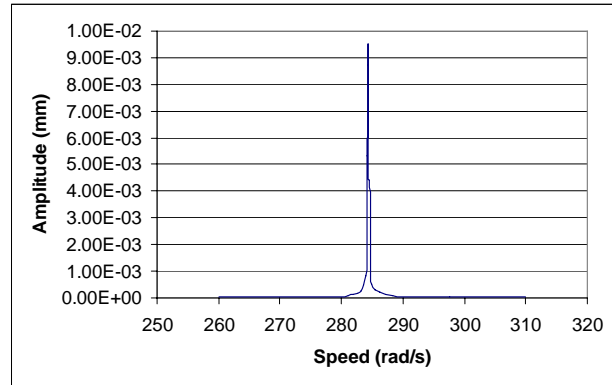

Fig. 6 Response of the system when ignoring the disk thickness

In the above figure the pick amplitude corresponds to the first natural frequency of the system which agrees with approximate methods available such as the Dunkerley's method.

For the second one when the thickness of the disk is also taken into account, the response curve changes significantly as depicted in Fig. 7.

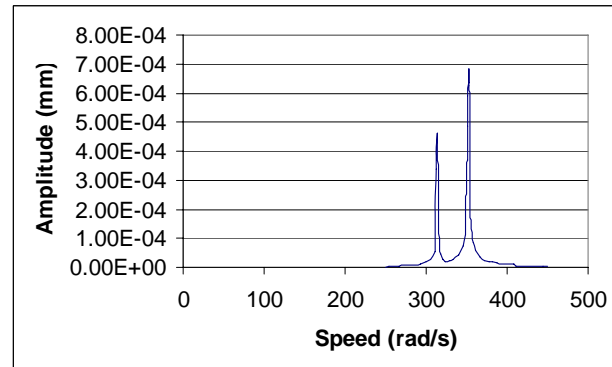

Fig. 7 Response of the system when considering the disk thickness

It is shown that the first natural frequency of the system has increased compared to the previous case. The increase of the natural frequency is attributed to the fact that by considering the disk width, the effective length of the shaft decreases and hence the system becomes more rigid. The decrease in the amplitude of vibration is another consequence of thickening the disk.

Third state which is the most completed and real one is achievable when both the disk and bearing thicknesses are taken into account. Fig. 8 corresponds to this case.

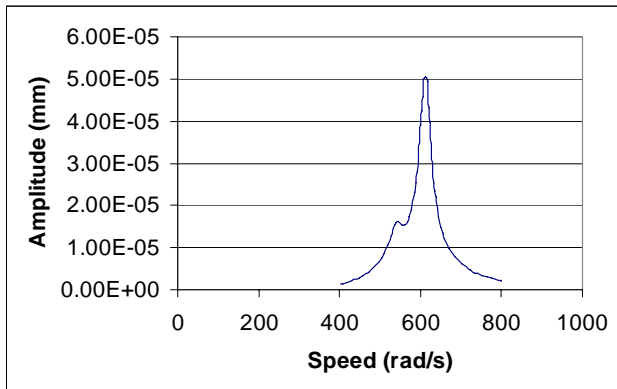

Fig. 8 Response of the system when considering both the disk and bearing thicknesses

It is observed from Fig. 8 that by considering the width of bearing the natural frequency increases again while the amplitude of vibration has decreased.

IV. CONCLUSION

In this paper the matrix transfer method is applied to rotor-bearing system. The transfer matrix of individual elements including the shaft, disk and the bearing are obtained. The merit of this approach over the conventional approximate methods is that the thickness of the disks and the bearings may also be considered. It is shown that the thickness of disks and bearings have considerable effect on the vibration behavior of the system. So by using material of this research more accurate answers would be achievable for different desired systems. This method can be applied to rotor-bearing systems with various configurations.

REFERENCES

- [1] Rao, S.S., 1983, Rotor Dynamics, John Wiley & Sons, Newyork
- [2] Pestel, E. C., and Leckie, F. A., 1963, Matrix Methods in Elastomechanics, McGrawHill, New york.
- [3] Prohl, M. A., 1945, "A General Method for Calculating Critical Speeds of Flexible Rotors", ASME J. Appl. Mech., Vol. 67, p. 142.
- [4] Lund, J. W., and Orcut, F.K., 1967, Calculations and Experiments on the Unbalance Response of a Flexible Rotor, ASME Journal of Engineering for Industry, Vol. 89 (4), pp.785-596.
- [5] Bansal, P. N., and Kirk, R. G., 1975, "Stability and Damped Critical Speeds of a Flexible Rotor in Fluid Film Bearings," ASME J. Ind., Series B, 97(4), pp. 1325-1332.
- [6] Tan, C.A., Kang, B., 1999, Free vibration of axially loaded, rotating Timoshenko shaft systems by the wave-train closure principle, International Journal of Solids and Structures, Vol 36, pp. 4031-4049.
- [7] Meriam, J.L, Kraige L.G, 1998, Dynamics, John Wiley & Sons, New york.
- [8] Beer, F.P, Johnston, J.R., 1992, Mechanics of materials, Mc Graw Hill, Singapore.
- [9] Timoshenko, S. P., Goodier, J.N., 1970, Theory of Elasticity, 3rd Ed., McGraw-Hill.

APPENDIX 1- SOME MATRICES

$$A_0 = \begin{bmatrix} 1 & 0 & 1 & 0 & 1 & 0 & 1 & 0 & 0 & 0 & 0 & 0 & 0 & 0 & 0 \\ 0 & \lambda_1 & 0 & \lambda_2 & 0 & \lambda_3 & 0 & \lambda_4 & 0 & 0 & 0 & 0 & 0 & 0 & 0 \\ \lambda_1^2 & 0 & -\lambda_2^2 & 0 & \lambda_3^2 & 0 & -\lambda_4^2 & 0 & 0 & 0 & 0 & 0 & 0 & 0 & 0 \\ 0 & \lambda_1^3 & 0 & -\lambda_2^3 & 0 & \lambda_3^3 & 0 & -\lambda_4^3 & 0 & 0 & 0 & 0 & 0 & 0 & 0 \\ 0 & 0 & 0 & 0 & 0 & 0 & 0 & 0 & 1 & 0 & 1 & 0 & 1 & 0 & 1 \\ 0 & 0 & 0 & 0 & 0 & 0 & 0 & 0 & 0 & \lambda_1 & 0 & \lambda_2 & 0 & \lambda_3 & 0 & \lambda_4 \\ 0 & 0 & 0 & 0 & 0 & 0 & 0 & 0 & \lambda_1^2 & 0 & -\lambda_2^2 & 0 & \lambda_3^2 & 0 & -\lambda_4^2 & 0 \\ 0 & 0 & 0 & 0 & 0 & 0 & 0 & 0 & 0 & \lambda_1^3 & 0 & -\lambda_2^3 & 0 & \lambda_3^3 & 0 & -\lambda_4^3 \\ 0 & 0 & 0 & 0 & 0 & 0 & 0 & 0 & 1 & 0 & 1 & 0 & -1 & 0 & -1 & 0 \\ 0 & 0 & 0 & 0 & 0 & 0 & 0 & 0 & 0 & \lambda_1 & 0 & \lambda_2 & 0 & -\lambda_3 & 0 & -\lambda_4 \\ 0 & 0 & 0 & 0 & 0 & 0 & 0 & 0 & \lambda_1^2 & 0 & -\lambda_2^2 & 0 & -\lambda_3^2 & 0 & \lambda_4^2 & 0 \\ 0 & 0 & 0 & 0 & 0 & 0 & 0 & 0 & 0 & \lambda_1^3 & 0 & -\lambda_2^3 & 0 & -\lambda_3^3 & 0 & \lambda_4^3 \\ -1 & 0 & -1 & 0 & 1 & 0 & 1 & 0 & 0 & 0 & 0 & 0 & 0 & 0 & 0 & 0 \\ 0 & -\lambda_1 & 0 & -\lambda_2 & 0 & \lambda_3 & 0 & \lambda_4 & 0 & 0 & 0 & 0 & 0 & 0 & 0 & 0 \\ -\lambda_1^2 & 0 & \lambda_2^2 & 0 & \lambda_3^2 & 0 & -\lambda_4^2 & 0 & 0 & 0 & 0 & 0 & 0 & 0 & 0 & 0 \\ 0 & -\lambda_1^3 & 0 & \lambda_2^3 & 0 & \lambda_3^3 & 0 & -\lambda_4^3 & 0 & 0 & 0 & 0 & 0 & 0 & 0 & 0 \end{bmatrix}$$

$$A_L [1...8,1...8] =$$

$$\begin{bmatrix} \cosh(\lambda_1 L) & \sinh(\lambda_1 L) & \cos(\lambda_2 L) & \sin(\lambda_1 L) & \cosh(\lambda_3 L) & \sinh(\lambda_1 L) & \cos(\lambda_4 L) & \sin(\lambda_1 L) \\ \sinh(\lambda_1 L)\lambda_1 & \cosh(\lambda_1 L)\lambda_1 & -\sin(\lambda_2 L)\lambda_2 & \cos(\lambda_2 L)\lambda_2 & \sinh(\lambda_3 L)\lambda_3 & \cosh(\lambda_3 L)\lambda_3 & -\sin(\lambda_4 L)\lambda_4 & -\cos(\lambda_4 L)\lambda_4 \\ \cosh(\lambda_1 L)\lambda_1^2 & \sinh(\lambda_1 L)\lambda_1^2 & -\cos(\lambda_2 L)\lambda_2^2 & -\sin(\lambda_2 L)\lambda_2^2 & \cosh(\lambda_3 L)\lambda_3^2 & \sinh(\lambda_3 L)\lambda_3^2 & -\cos(\lambda_4 L)\lambda_4^2 & -\sin(\lambda_4 L)\lambda_4^2 \\ \sinh(\lambda_1 L)\lambda_1^3 & \cosh(\lambda_1 L)\lambda_1^3 & \sinh(\lambda_2 L)\lambda_2^3 & -\cos(\lambda_2 L)\lambda_2^3 & \sinh(\lambda_3 L)\lambda_3^3 & \cosh(\lambda_3 L)\lambda_3^3 & \sinh(\lambda_4 L)\lambda_4^3 & -\cos(\lambda_4 L)\lambda_4^3 \\ 0 & 0 & 0 & 0 & 0 & 0 & 0 & 0 \\ 0 & 0 & 0 & 0 & 0 & 0 & 0 & 0 \\ 0 & 0 & 0 & 0 & 0 & 0 & 0 & 0 \\ 0 & 0 & 0 & 0 & 0 & 0 & 0 & 0 \end{bmatrix}$$

$$A_L [1...8,9...16] =$$

$$\begin{bmatrix} 0 & 0 & 0 & 0 & 0 & 0 & 0 & 0 \\ 0 & 0 & 0 & 0 & 0 & 0 & 0 & 0 \\ 0 & 0 & 0 & 0 & 0 & 0 & 0 & 0 \\ 0 & 0 & 0 & 0 & 0 & 0 & 0 & 0 \\ -\cosh(\lambda_1 L) & -\sinh(\lambda_1 L) & -\cos(\lambda_2 L) & -\sin(\lambda_2 L) & \cosh(\lambda_3 L) & \sinh(\lambda_3 L) & \cos(\lambda_4 L) & \sin(\lambda_4 L) \\ -\sinh(\lambda_1 L)\lambda_1 & -\cosh(\lambda_1 L)\lambda_1 & \sin(\lambda_2 L)\lambda_2 & -\cos(\lambda_2 L)\lambda_2 & \sinh(\lambda_3 L)\lambda_3 & \cosh(\lambda_3 L)\lambda_3 & -\sin(\lambda_4 L)\lambda_4 & \cos(\lambda_4 L)\lambda_4 \\ -\cosh(\lambda_1 L)\lambda_1^2 & -\sinh(\lambda_1 L)\lambda_1^2 & \cos(\lambda_2 L)\lambda_2^2 & \sin(\lambda_2 L)\lambda_2^2 & \cosh(\lambda_3 L)\lambda_3^2 & \sinh(\lambda_3 L)\lambda_3^2 & -\cos(\lambda_4 L)\lambda_4^2 & -\sin(\lambda_4 L)\lambda_4^2 \\ -\sinh(\lambda_1 L)\lambda_1^3 & -\cosh(\lambda_1 L)\lambda_1^3 & -\sin(\lambda_2 L)\lambda_2^3 & \cos(\lambda_2 L)\lambda_2^3 & \sinh(\lambda_3 L)\lambda_3^3 & \cosh(\lambda_3 L)\lambda_3^3 & \sin(\lambda_4 L)\lambda_4^3 & -\cos(\lambda_4 L)\lambda_4^3 \end{bmatrix}$$

$$A_L [9...16, 1...8] =$$

$$\begin{bmatrix} 0 & 0 & 0 & 0 & 0 & 0 & 0 & 0 \\ 0 & 0 & 0 & 0 & 0 & 0 & 0 & 0 \\ 0 & 0 & 0 & 0 & 0 & 0 & 0 & 0 \\ 0 & 0 & 0 & 0 & 0 & 0 & 0 & 0 \\ \cosh(\lambda_1 L) & \sinh(\lambda_1 L) & \cos(\lambda_2 L) & \sin(\lambda_2 L) & \cosh(\lambda_3 L) & \sinh(\lambda_3 L) & \cos(\lambda_4 L) & \sin(\lambda_4 L) \\ \sinh(\lambda_1 L)\lambda_1 & \cosh(\lambda_1 L)\lambda_1 & -\sin(\lambda_2 L)\lambda_2 & \cos(\lambda_2 L)\lambda_2 & \sinh(\lambda_3 L) & \cosh(\lambda_3 L) & -\sin(\lambda_4 L)\lambda_4 & \cos(\lambda_4 L)\lambda_4 \\ \cosh(\lambda_1 L)\lambda_1^2 & \sinh(\lambda_1 L)\lambda_1^2 & -\cos(\lambda_2 L)\lambda_2^2 & -\sin(\lambda_2 L)\lambda_2^2 & \cosh(\lambda_3 L)\lambda_3^2 & \sinh(\lambda_3 L)\lambda_3^2 & -\cos(\lambda_4 L)\lambda_4^2 & \sin(\lambda_4 L)\lambda_4^2 \\ \sinh(\lambda_1 L)\lambda_1^3 & \cosh(\lambda_1 L)\lambda_1^3 & \sin(\lambda_2 L)\lambda_2^3 & -\cos(\lambda_2 L)\lambda_2^3 & \sinh(\lambda_3 L)\lambda_3^3 & \cosh(\lambda_3 L)\lambda_3^3 & \sin(\lambda_4 L)\lambda_4^3 & -\cos(\lambda_4 L)\lambda_4^3 \end{bmatrix}$$

$$A_L [9...16, 9...16] =$$

$$\begin{bmatrix} \cosh(\lambda_1 L) & \sinh(\lambda_1 L) & \cos(\lambda_2 L) & \sin(\lambda_2 L) & -\cosh(\lambda_3 L) & -\sinh(\lambda_3 L) & -\cos(\lambda_4 L) & -\sin(\lambda_4 L) \\ \sinh(\lambda_1 L)\lambda_1 & \cosh(\lambda_1 L)\lambda_1 & -\sin(\lambda_2 L)\lambda_2 & \cos(\lambda_2 L)\lambda_2 & -\sinh(\lambda_3 L)\lambda_3 & \cosh(\lambda_3 L)\lambda_3 & -\sin(\lambda_4 L)\lambda_4 & \cos(\lambda_4 L)\lambda_4 \\ \cosh(\lambda_1 L)\lambda_1^2 & \sinh(\lambda_1 L)\lambda_1^2 & -\cos(\lambda_2 L)\lambda_2^2 & -\sin(\lambda_2 L)\lambda_2^2 & \cosh(\lambda_3 L)\lambda_3^2 & \sinh(\lambda_3 L)\lambda_3^2 & -\cos(\lambda_4 L)\lambda_4^2 & \sin(\lambda_4 L)\lambda_4^2 \\ \sinh(\lambda_1 L)\lambda_1^3 & \cosh(\lambda_1 L)\lambda_1^3 & \sin(\lambda_2 L)\lambda_2^3 & -\cos(\lambda_2 L)\lambda_2^3 & \sinh(\lambda_3 L)\lambda_3^3 & \cosh(\lambda_3 L)\lambda_3^3 & \sin(\lambda_4 L)\lambda_4^3 & -\cos(\lambda_4 L)\lambda_4^3 \\ 0 & 0 & 0 & 0 & 0 & 0 & 0 & 0 \\ 0 & 0 & 0 & 0 & 0 & 0 & 0 & 0 \\ 0 & 0 & 0 & 0 & 0 & 0 & 0 & 0 \\ 0 & 0 & 0 & 0 & 0 & 0 & 0 & 0 \end{bmatrix}$$