

# Optoelectronic Automated System for Length and Profile Measurements

L. C. Gómez-Pavón, M. A. Rojas Aparicio, E. Juárez Ruiz, M. A. Flores Guerrero,  
and O. Gómez-de la Fuente

**Abstract**—In this work the design and characterization of an optoelectronic automated measurement system it is presented. The optoelectronic devices of this system are an optical transmitter, the optical components and the optical receiver, which were selected for a great precision of the system. The mechanical system allows free displacement of the components as well as the devices that generate the movement. The results, length and profile of the objects are display in LabView.

**Keywords**—Automated, optoelectronic, triangulation method.

## I. INTRODUCTION

NOWADAYS, there are numerous instances, mainly in industrial applications, which require obtaining with greater precision and speed the dimensions of an object. For instance, in industrial processes these requirements are necessary with the purpose of reducing costs and time of operation. Moreover, some times the need to achieve noninvasive and nondestructive tests cause that the conventional techniques of measurement are unsuitable [1]. Also, diverse forms and methods exist to obtain such dimensions, such as the optical sensors and triangulation method [2].

The introduction of sensing by laser triangulation technique in the market was seen like an alternative to the measurements without contact [3]. These kinds of sensors give the same information without touch the object in comparison with a variable differential transformer or some contact test. A triangulation sensor consists of three subsystems: transmitter, receiver and electronic processor. A transmitter to project a

light spot on the object; the lenses system focuses the light reflected on a light sensible device, the receiver. If the object changes its position, the spot projected on the detector also changes. Therefore, the receiver could be a position sensitive detector (PSD). The PSD's are efficient and the required processing is simple, an advantage is the speed, the data reason can be in order of 200 kHz [4]. Some measurement techniques to obtain the surface geometry of an object for industrial or research applications are: 1) dot based technique: laser radar, laser triangulation; 2) line based technique: laser line triangulation and; 3) area based techniques: shape from shading, depth from focus/defocus, photogrammetry and phase measurement profilometry [4].

The operation of triangulation method is based on the projection of laser spot light on the surface to measure with a determined angle of the laser beam, a lens is arranged to focus the image of the surface marked on the detector. It is possible to know the global coordinates of the points generated by the laser on the detector by determining the coordinates of the points on it. A measurement scheme of this method is shown in Fig. 1. The beam of light emitted by the laser diode is focused on a surface in point A. The angle of incidence assumes normal. Spot in this surface is seen under an angle, in a photodetector PSD, the image point B (after crossing the focus optics). Changing the distance of the object, gives like result a displacement of spot projected on the photodetector, point B' [5].

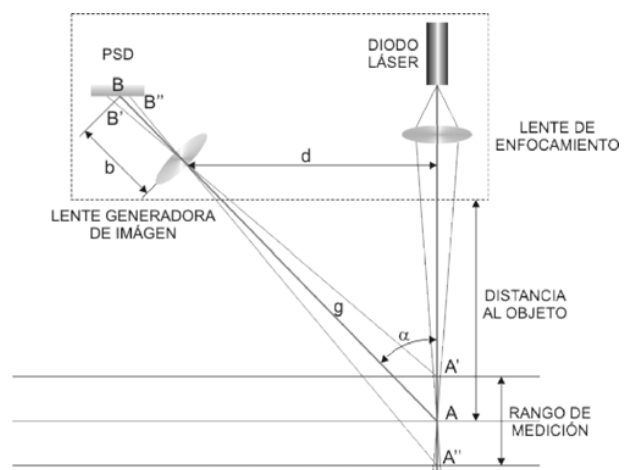

Fig. 1 Scheme of triangulation laser method

Manuscript received September 10, 2006. This work was supported in part by the VIEP-BUAP through project 4/I/ING/05.

L. C. Gómez-Pavón is with the Fac. de Ciencias de la Electrónica-Benemérita Universidad Autónoma de Puebla, San Claudio y 18 Sur, Edif. 129-CU, Col. San Manuel, Puebla, México (phone: 222-217-6062; e-mail: gpavon@ece.buap.mx).

M. A. Rojas Aparicio is with the Fac. de Ciencias de la Electrónica-Benemérita Universidad Autónoma de Puebla, San Claudio y 18 Sur, Edif. 129-CU, Col. San Manuel, Puebla, México (e-mail: mik\_alexs@hotmail.com).

E. Juárez Ruiz is with the Fac. de Ciencias de la Electrónica-Benemérita Universidad Autónoma de Puebla, San Claudio y 18 Sur, Edif. 129-CU, Col. San Manuel, Puebla, México (e-mail: ejuarez@ece.buap.mx).

M. A. Flores Guerrero is with the FCE-Benemérita Universidad Autónoma de Puebla, San Claudio y 18 Sur, Edif. 129-CU, Col. San Manuel, Puebla, México (e-mail: maverick3mx@hotmail.com).

O. Gómez-de la Fuente is with the Fac. de Ciencias de la Electrónica-Benemérita Universidad Autónoma de Puebla, San Claudio y 18 Sur, Edif. 129-CU, Col. San Manuel, Puebla, México (e-mail: tavoludo@hotmail.com).

The vertical separation between the point  $A'$  and the point  $B'$  is given by the geometric relation:

$$A' = \frac{db \cos \alpha}{b \sin \alpha + BB'} \quad (1)$$

Multiple factors exist that influence in the final capacity and precision of the system, such as: light source, superficial characteristics and capture device.

## II. METHODOLOGY

The experimental design of the sensing system by the implementation of triangulation method for this work it was accomplished in three subsystems: A) The triangulation method scheme, B) the data acquisition and processing system and, C) the mechanical system.

### A. Triangulation Method Scheme

In this system a laser diode with a power of 3mW at 650nm was used like transmitter. The receiver is a PSD DL100-7PCBA3 with a resolution of  $0.5\mu\text{m}$  and a linearity of 1%. This PSD is a duolateral position sensing module composed of a  $10\text{mm} \times 10\text{mm}$  active area position sensing photodiode and associated circuitry that contains amplifiers that convert the light generated currents into voltages. The voltages are then processed to provide a bipolar signal for the  $X$  axis and a bipolar signal for the  $Y$  axis. The currents are further processed to provide a voltage for the total  $X$  current and the total  $Y$  current. These voltages represent the light intensity.

### B. Data Acquisition and Processing System

The acquisition system is designed based on the type of signals given by the PSD, four voltages that allow us to know with accuracy the position of the reflected beam on the surface of the object. The designed system gives a complete autonomy to the measurement process using a combination of hardware and software.

The first part of this system is the signal conditioning in which the ranges of the signs to acquire are adjusted to be adapted to the voltage or current ranges for which the electronic components to use are designed. It was introduced an analogical multiplexer Texas Instruments MPC508A, which is used for the 4:1 multiplexing necessary to acquire one by one the analogical voltages provided by PSD. The control of this multiplexer is achieved by digital signals and it allows to multiplex analogical signals in ranges of  $\pm 15$  Volts. An analogical digital converter ADS7804 Burr Brown with 12 bits resolution and a dynamic range of  $\pm 10$  Volts is used for data conversion, which allow that an analogical continuous signal is represented by means of a binary proportional value. A PIC16F877A is used for two main functions in the system. First one, it is to operate like a 12:4 multiplexer to be able to send the results of the analogical digital conversions carried out by the status port of the parallel connector. The second one, it is operate as a control for the motors, which perform the object displacements to being measured in the mechanical system.

Regarding the software designed, it was developed with National Instruments LabView 8.20. The fundamental function of the program is to provide the control signals for the data acquisition, to process the information acquired and to display the results from this information. These results can be better appreciated in the front panel of the virtual instrument, which show the profile graphic, the voltage and displacement values as well as the LED array that indicate the reading in the port. Also it is possible to observe the sign flag, the decimal exact value of the conversion and their corresponding binary value.

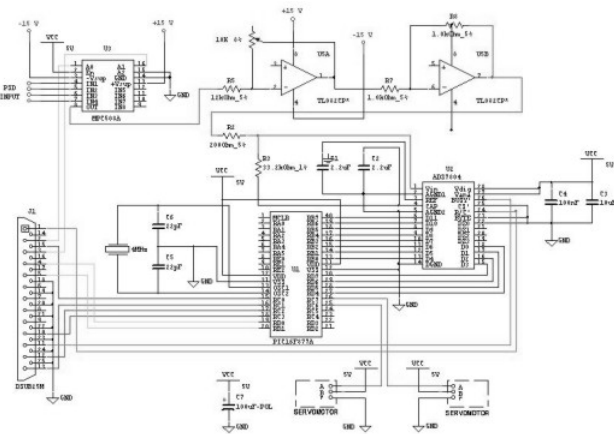

Fig. 2 Electronic diagram for data acquisition system

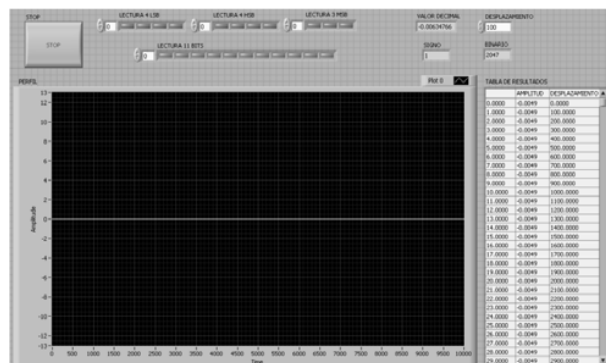

Fig. 3 Front panel of the virtual instrument

### C. Mechanical System

The mechanical system design was based on the triangulation method scheme showed in Fig. 1. We consider that the transmitter and receiver devices were fixed in the system and, with the aim to achieve the laser scanning on the object, the last one have movement on two axis,  $X$  and  $Z$ . The mechanical design program used was SolidWorks and the system components are: three bases, a system of eight links for the vertical movement and it join the fixed base with the part with movement, which is a table where the object is placed. In this part two servo motors are used with the respective worm. In Fig. 4 it is shown the SolidWorks design as well as the experimental measured system.

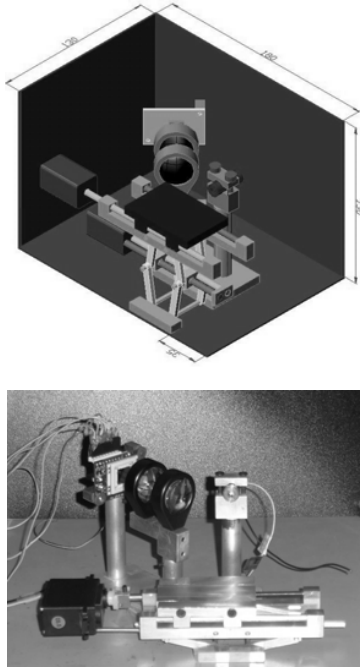

Fig. 4 Design and experimental setup of the measured system

### III. RESULTS

The experiment was achieved with different materials. However, with the aim to have a reliable characterization a mirror was used, due to its high reflectivity. It was achieved a scanning over the sample and the voltage values was obtained. In Fig. 5, it is shown the spot position on PSD regarding the displacement length. Because the PSD works with a current difference, when the scanning over the PSD is achieved the current difference is zero in the geometric center of this. This performance is demonstrated in Fig. 4. It was observed the change from negative to positive voltage values on the PSD center. From these voltages it is possible to know the position spot in the PSD. Moreover, with this values voltage it was calculated the object length taking into account the graphic obtained for the mirror, which is the reference.

The measurements for objects with different lengths were carried out: 2 cm, 1.5 cm, 0.5 cm. It is important to mention that in all the cases the difference between the measurements of the sensing system with the one obtained directly with a ruler was around 0.3 mm. Furthermore, the measures were achieved on objects with specular and diffuse reflection. The experimental procedure to obtain the length of the samples is the following: The sample is placed to measure in an equal position to which it was used like reference. Later, the spot is focused on the sample and it is determined the moment in that this touches the sample edge. Micrometric displacements of the spot are moving on the sample until the spot does not have contact with this one. The software process the data obtained and the object length is displayed as well as the object profile.

In Fig. 6 and 7, it is presented the spot position regarding the displacement length for a metallic and a diffuse piece, respectively.

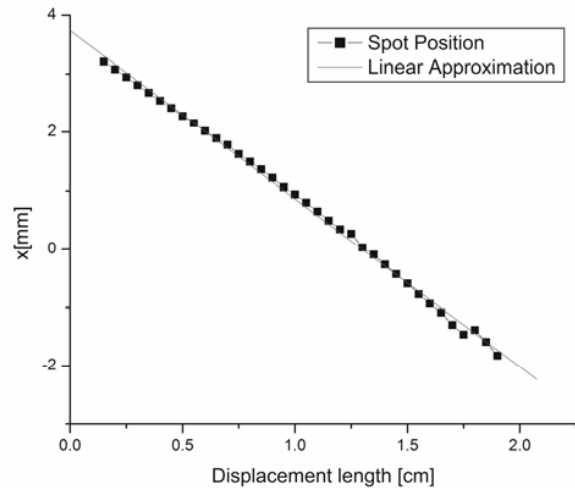

Fig. 5 Spot position on sensor surface regarding the displacement length of the mirror

In Fig. 6, the scanning start before the nut; the laser beam is focused on the metal from a displacement length of 3.5mm, approximately. The empty length of the nut is from 5mm to 7mm. After that the laser is focused on the metallic part again. In Fig. 7, the object has a more complicated surface and due to the PSD precision it was possible to detect the changes in the shape of the piece.

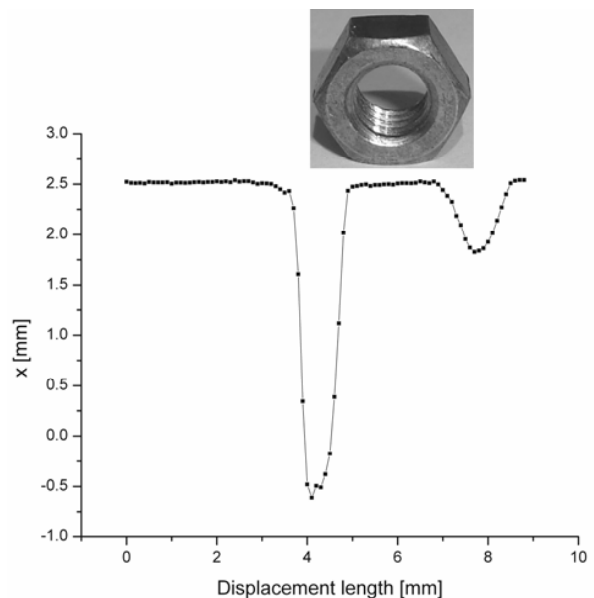

Fig. 6 Spot position on sensor surface regarding the displacement length of the nut

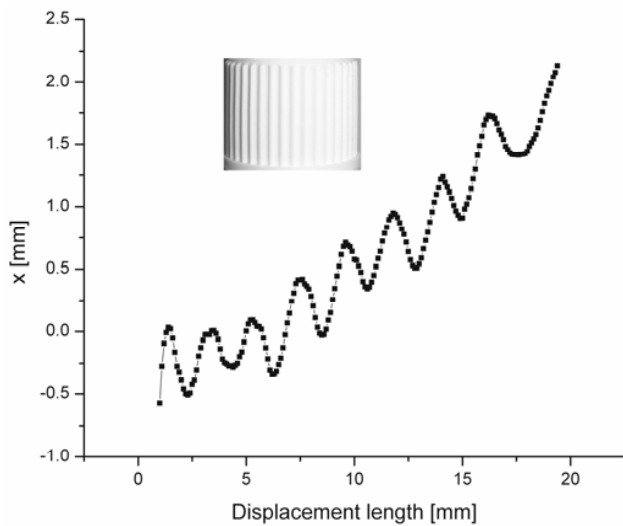

Fig. 7 Spot position on PSD surface in function of the displacement length of a diffuse piece

#### IV. CONCLUSION

In conclusion, it was achieved an automated system which not only is capable to obtain the length measurement of objects but also shown the profile of these one. The advantages of this system are the time for data acquisition and processing as well as the precision of the sensing system.

#### REFERENCES

- [1] Anssi Mäkynen, *Position-sensitive Devices and Sensor Systems for Optical Tracking and Displacement Sensing Applications*. Oulu. 2000.
- [2] I. Sinclair, *Sensors and Transducers*, Third Edition, Ed. Newnes (Reed Elsevier group), 2001.
- [3] M. Dumberger, *Sensor Technology and Design*, Vol. 19, No. 7, 2002.
- [4] Gareth Bradshaw, *Non-contact Surface Geometry Measurement Techniques*, Dublin, Trinity College, 1999.
- [5] D. Hüser and H. Rothe, Robust averaging of signals triangulation sensors, *Meas. Sci. Technol.*, 9, 1017, 1998.