

# Efficiency of Compact Organic Rankine Cycle System with Rotary-Vane-Type Expander for Low-Temperature Waste Heat Recovery

Musthafah b. Mohd.Tahir, Noboru Yamada, and Tetsuya Hoshino

**Abstract**—This paper describes the experimental efficiency of a compact organic Rankine cycle (ORC) system with a compact rotary-vane-type expander. The compact ORC system can be used for power generation from low-temperature heat sources such as waste heat from various small-scale heat engines, fuel cells, electric devices, and solar thermal energy. The purpose of this study is to develop an ORC system with a low power output of less than 1 kW with a hot temperature source ranging from 60°C to 100°C and a cold temperature source ranging from 10°C to 30°C. The power output of the system is rather less due to limited heat efficiency. Therefore, the system should have an economically optimal efficiency. In order to realize such a system, an efficient and low-cost expander is indispensable. An experimental ORC system was developed using the rotary-vane-type expander which is one of possible candidates of the expander. The experimental results revealed the expander performance for various rotation speeds, expander efficiencies, and thermal efficiencies. Approximately 30 W of expander power output with 48% expander efficiency and 4% thermal efficiency with a temperature difference between the hot and cold sources of 80°C was achieved.

**Keywords**—Organic Rankine cycle, Thermodynamic cycle, Thermal efficiency, Turbine efficiency, Waste heat recovery, Power generation, Low temperature heat engine.

## I. INTRODUCTION

TO mitigate the world's energy problems and the extent of global warming, renewable sources of energy must be used. Waste heat is one such renewable source of energy. In industries around the world, a large amount of low-temperature heat is lost in the form of waste heat. According to a report by the Energy Conservation Center of Japan [1], industrial waste heat in Japan amounts to  $2.7 \times 10^5$  Tcal/year. This is equivalent to approximately 70% of the annual commercial and residential energy consumption in Japan. The report also mentions that the

temperature level of 45% of the total waste heat is 100°C and below. Therefore, it is important to develop an economically efficient waste heat recovery system that can generate power and/or electricity from low-temperature heat sources (less than 100°C). Furthermore, the recovery system must have a compact size because waste heat is a highly distributed energy source. The power generated by the recovery system would be less due to limited heat efficiency.

Thus far, various waste heat recovery systems have been proposed and developed. The most feasible and common used waste heat recovery system is the organic Rankine cycle (ORC). The ORC uses an organic fluid with a low boiling point. Yamamoto et al. [2] described the effects of the thermal properties of an organic working fluid on the turbine power output of an ORC system. Free Power Co., Ltd., introduced a commercial ORC system that converts waste heat into electricity [3]. Yamaguchi et al. [4] developed a unique Rankine cycle system using supercritical carbon dioxide (CO<sub>2</sub>) as the working fluid, and they elucidated its potential as a solar thermal energy conversion system. Advanced cycles such as the Kalina cycle and the Uehara cycle have been developed in order to generate power from a small temperature difference between hot and cold sources (e.g. 15 K to 25 K in an ocean thermal energy conversion (OTEC) system) [5]. Most of the research and development related to waste heat recovery systems has been carried out for a power output greater than 10 kW. For example, the turbine power outputs of the ORC system developed by Ebara Co., Ltd., [6] and Free Power Co., Ltd., are approximately 50 kW and 120 kW, respectively; those of OTEC systems and geothermal plants are usually above 30 kW. An ORC system with a power output of less than 1 kW has not yet been extensively studied and developed. However, the current energy and environmental conditions worldwide are such that there will soon be a requirement for a compact ORC system that can be easily installed at the location where waste heat is generated.

The purpose of this study is to develop an economically efficient ORC system with a turbine power output of less than 1 kW. In order to realize such a system, an efficient and low cost expander is indispensable. In this study, we developed an experimental ORC system using a rotary-vane-type expander, which is one of possible candidates of the expander. Other commercially available components were also used. The system is equipped with a hot source with a temperature range of 60–100°C and a cold source with a temperature range of

Musthafah MT is with the Graduate school of Energy and Environment Science, Nagaoka University of Technology, 1603-1 Kamitomioka-machi, Nagaoka-shi, Niigata 940-2188, Japan (phone: +81-258-47-9748; fax: +81-258-47-9748; e-mail: musmt@stn.nagaokaut.ac.jp). He is also an academic staff of Malaysia University of Technical, Melaka (UTeM).

Noboru Yamada is with Nagaoka University of Technology, Nagaoka-shi, Niigata, Japan. (e-mail: noboru@nagaokaut.ac.jp).

Tetsuya Hoshino is with Nagaoka University of Technology, Nagaoka-shi, Niigata, Japan. He is now with ADTEC Engineering, Niigata, Japan (e-mail: t\_hoshino@adtec-eng.co.jp).

10–30°C. The proposed system is capable of producing an expander power output of approximately 50 W. A fundamental experiment was conducted and the expander performance for various rotation speeds was investigated. Furthermore, the expander and thermal efficiencies of the proposed system were calculated and analyzed.

### Nomenclature

$\dot{m}$	: Mass flow rate, kg/s
$W$	: Work, kJ/kg
$h$	: Enthalpy, kJ/kg
$n$	: Rotational speed, rpm
$P$	: Pressure, MPa
$T$	: Temperature, °C or K
$\dot{W}_P$	: Pump power, W
$\dot{W}_T$	: Turbine power, W
$\dot{Q}_C$	: Heat released at condenser, W

### Subscripts

$C$	: Condenser
$E$	: Evaporator
$P$	: Pump
$T$	: Turbine/Expander
$WF$	: Working fluid
$th$	: Theoretical

### Greek symbols

$\eta_{R\_th}$	: Theoretical thermal efficiency
$\eta_{R1}$	: Thermal efficiency without pump power loss
$\eta_{R2}$	: Thermal efficiency with pump power loss

## II. OPERATING PRINCIPLE AND EFFICIENCY DEFINITION OF ORC

Fig. 1 shows the schematic diagram of the operating principle of a closed Rankine cycle. This ORC uses an organic working fluid. The Rankine cycle consists of five key components: a pump, an evaporator, an expander, a condenser, and a working fluid. The evaporator and condenser are heat exchangers that absorb heat into the cycle and release it from the cycle [7]. The cycle commences when the pump pushes the working fluid to the evaporator. In the evaporator, the water at the hot source heats the working fluid to a saturated or superheated vapour state. Then, the vapour expands and rotates the expander to produce power. After the vapour leaves the turbine, the water at the cold source cools and condenses the working fluid into the liquid state in the condenser. Then, the pump re-circulates the fluid. Fig. 2 shows the pressure–enthalpy ( $p$ – $h$ ) diagram corresponding to Fig.1.

Process 1→2 shown in Fig.1 and Fig.2 is the isentropic compression by the pump. The ideal pump power is given by

$$\dot{W}_P = \dot{m}_{WF} (h_2 - h_1). \quad (1)$$

Process 2→3 is the heating of the working fluid at a constant pressure in the evaporator. The heat absorbed by the working fluid is given by

$$\dot{Q}_E = \dot{m}_{WF} (h_3 - h_2). \quad (2)$$

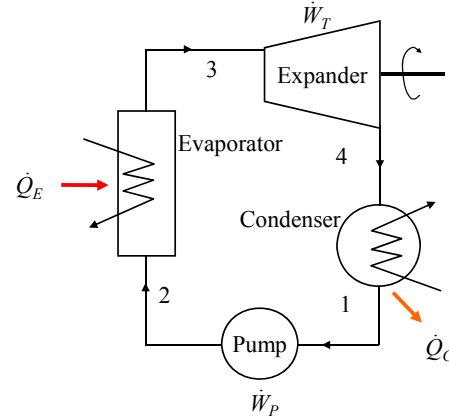

Fig. 1 Schematic diagram of closed Rankine cycle operation

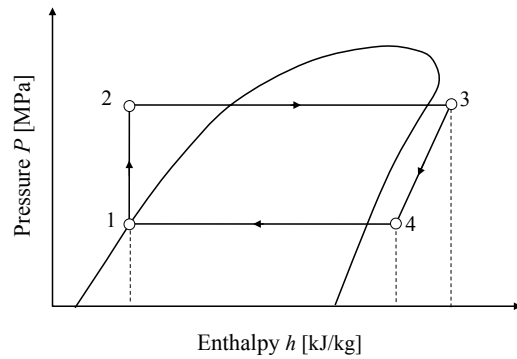

Fig. 2  $p$ – $h$  diagram of closed Rankine cycle

Process 3→4 is the isentropic expansion by the expander. The expander power is given by

$$\dot{W}_T = \dot{m}_{WF} (h_3 - h_4) \quad (3)$$

Process 4→1 is the cooling of the working fluid at a constant pressure in the condenser. The heat released from the working fluid is given by

$$\dot{Q}_C = \dot{m}_{WF} (h_4 - h_1) \quad (4)$$

The theoretical thermal efficiency of the ORC is calculated as follows:

$$\begin{aligned}\eta_{R\_th} &= \frac{\text{Net work input}}{\text{Total heat input}} \\ &= \frac{(\text{Expander power } \dot{W}_T) - (\text{Pump power } \dot{W}_P)}{\text{Heat gain in Evaporator } \dot{Q}_E} \quad (5) \\ &= \frac{(h_3 - h_4) - (h_2 - h_1)}{h_3 - h_2}\end{aligned}$$

If the pump work  $\dot{W}_P$  is significantly less than expander power, then  $\dot{W}_P$  can be ignored. If process 1→2 occurs at a low pump pressure without any temperature change, or by isentropic compression, then  $(h_3 - h_2)$  in Eq. 5 can be replaced with  $(h_3 - h_1)$ . The theoretical thermal efficiency is given by

$$\eta_{R\_th} = \frac{(h_3 - h_4) - (h_2 - h_1)}{h_3 - h_2} \cong \frac{h_3 - h_4}{h_3 - h_1} \quad (6)$$

The measured thermal efficiency that does not take into account the pump power loss, is given by

$$\eta_{R1} = \frac{\dot{W}_T}{(h_3 - h_1)\dot{m}_{WF}} \quad (7)$$

The measured thermal efficiency that takes into account the pump power loss, is given by

$$\eta_{R2} = \frac{\dot{W}_T - \dot{W}_P}{(h_3 - h_1)\dot{m}_{WF}} \quad (8)$$

The theoretical expander power is calculated using the following equation

$$\dot{W}_{T\_th} = \dot{m}_{WF}(h_3 - h_1) \quad (9)$$

The expander efficiency is calculated using the following equation

$$\eta_T = \frac{\dot{W}_T}{\dot{W}_{T\_th}} \quad (10)$$

In the above equations, the enthalpies were calculated using the measured pressure and temperature in the experiment. REFPROP ver.8, developed by the NIST [8], was used in the calculations. The mass flow rate of the working fluid was also measured in the experiment.

### III. EXPERIMENT USING COMPACT ORC SYSTEM

#### A. Rotary-vane-type expander

The theoretical thermal efficiency of the ORC system for a small temperature difference between the hot and cold sources (60°C–80°C in our study) is usually low because of the low expander efficiency. A few studies focusing on the development of an efficient compact expander for low temperature ORC systems have been conducted. For this purpose, a compact rotary-vane-type expander, categorized as a displacement-type

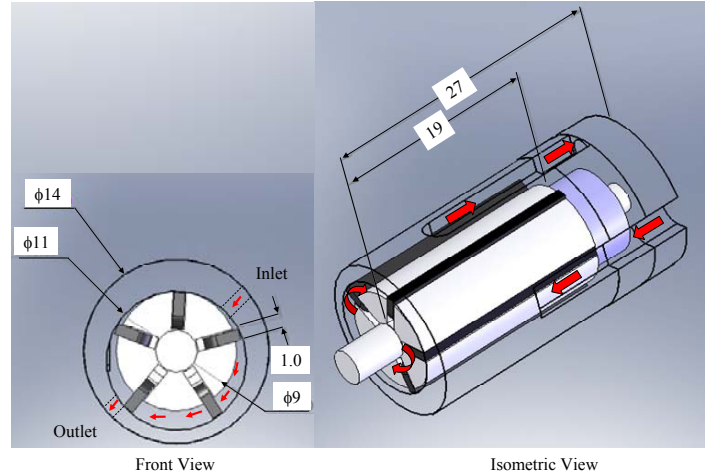

Fig. 3 Rotary-vane-type expander used in the proposed ORC system

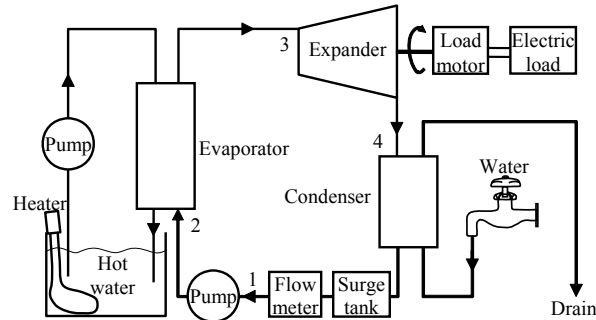

Fig. 4 Experimental apparatus of the proposed ORC system

TABLE I PRINCIPAL SPECIFICATIONS OF THE PROPOSED ORC SYSTEM

Working fluid	HFC-245fa ( $\text{CH}_3\text{CH}_2\text{CHF}_2$ ), Molecular weight: 134.05, Boiling temperature: 14.9°C
Heat exchangers (evaporator & condenser)	Brazed plate heat exchanger, Heat conduction area (Evaporator): 0.144 m <sup>2</sup> Heat conduction area (Condenser): 0.168 m <sup>2</sup>
Hot source	Circulated water, Temperature range: 60~90°C
Heater	Electrical heater, Maximum output: 1kW
Cold source	Tap water, Temperature range: 7~12°C
Expander	Rotary-vane-type expander
Working fluid pump	Rietschle Thomas 5002F Diaphragm pump, Typical volume flow rate: 0.4 L/min

expander, was employed. This expander has a high efficiency and a low cost due to its simple mechanism and minimal mechanical parts.

Fig. 3 shows the structure of the rotary-vane-type expander.

It comprises five vanes slotted into one rotor. The rotor rotates inside a larger circular cavity and the vanes maintain contact with the walls as the rotor rotates. The centres of these two circles are offset to create expansion cell volume. The vanes are allowed to slide in and out of the rotor. The volume of the vane chambers increase from the inlet to the outlet. The expander can be operated at a high rotation speed of up to 7,000 rpm and at a high pressure of up to 1.1 MPa.

### B. Experimental apparatus and method

Fig. 4 shows the schematic diagram of the proposed ORC system that can potentially produce an expander power output of 50 W. Table I shows the principal specifications of the proposed system. Most of the system components except the expander are commercial items that were used without any particular modifications. HFC-245fa was used as the working fluid because it is a dry liquid and it provides relatively higher efficiency than other fluids in a low temperature range [9]. The critical temperature of HFC-245fa is 427.16 K (approximately 154°C), which is considerably higher than the highest operating temperature expected in the proposed system. A small diaphragm pump was used to circulate the working fluid. In the experiment, the volume flow rate of the working fluid was maintained constant ( $140 \times 10^{-3}$  L/min) by adjusting the pump power. Water that was heated by an electric heater through circulation was used as the hot source. Tap water, which was made to flow into the condenser and out to the drain, was used as the cold source. The range of temperature difference between the hot source and the cold source was maintained at  $\Delta T = 60^\circ\text{C}$ ,  $70^\circ\text{C}$ , and  $80^\circ\text{C}$ . Plate-type heat exchangers were used for both the evaporator and the condenser. The expander load was adjusted to measure the torque for various rotation speeds; the load adjustment was done by changing the number of electric bulbs connected to the load motor. At the same time, the evaporator pressure, condenser pressure, and working fluid pump power were also measured. All measurements were performed after the temperatures of the hot and cold sources became stable.

### C. Results and discussion

Figs. 5 and 6 show the expander torque and power for  $\Delta T = 60^\circ\text{C}$ ,  $70^\circ\text{C}$ , and  $80^\circ\text{C}$  as a function of expander rotation speed. The rotation speed at maximum torque and maximum power increased as  $\Delta T$  increased. In the case of  $\Delta T = 80^\circ\text{C}$ , maximum torque and maximum power reached 115 N·mm and 32 W, respectively; similar results were obtained for the cases of  $\Delta T = 60^\circ\text{C}$  and  $70^\circ\text{C}$ . The maximum torque and power increment was caused by pressure difference  $P_E - P_C$  ( $P_E$  and  $P_C$  denote the pressure inside the evaporator and condenser, respectively), which is almost the same as the pressure difference between the

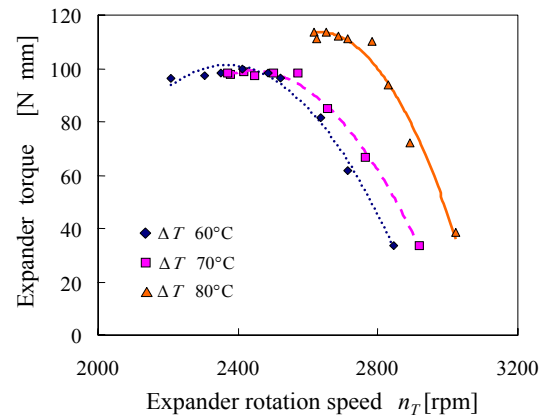

Fig. 5 Relationship between expander torque and rotation speed for  $\Delta T = 60^\circ\text{C}$ ,  $70^\circ\text{C}$ , and  $80^\circ\text{C}$

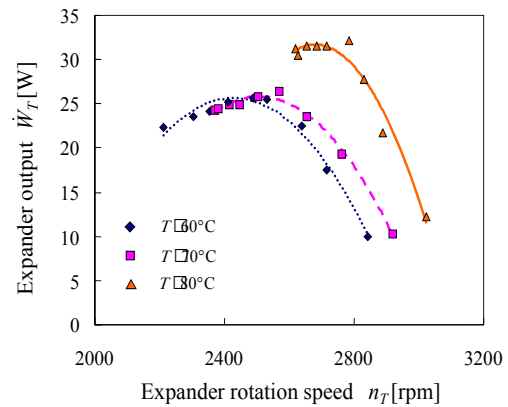

Fig. 6 Relationship between expander power and rotation speed for  $\Delta T = 60^\circ\text{C}$ ,  $70^\circ\text{C}$ , and  $80^\circ\text{C}$

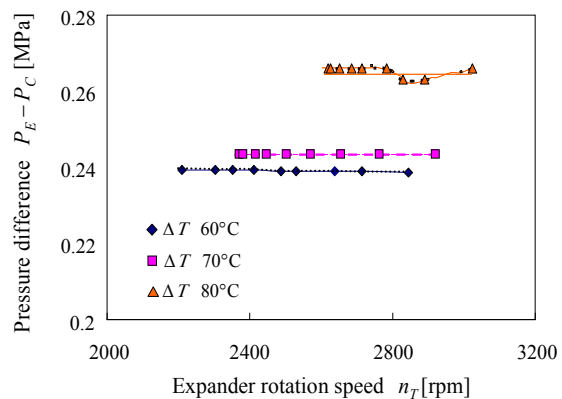

Fig. 7 Pressure difference between  $P_E$  and  $P_C$  for  $\Delta T = 60^\circ\text{C}$ ,  $70^\circ\text{C}$ , and  $80^\circ\text{C}$

expander inlet and outlet in the case of small systems.

Fig. 7 shows the graph plotted for values of  $P_E - P_C$  corresponding to Figs. 5 and 6. Table II shows the average evaporator and condenser pressures. It can be observed that  $P_E - P_C$  is the highest in the case of  $\Delta T = 80^\circ\text{C}$ . Furthermore,  $P_E - P_C$  is almost stable during change in expander rotation speed.

These results imply that the pressure difference dominates the expander torque and power. In other words, an appropriate working fluid that can maximize the pressure difference for a particular temperature difference should be selected.

Table III lists the values of the expander efficiency and expander power for  $\Delta T = 60^\circ\text{C}$ ,  $70^\circ\text{C}$ , and  $80^\circ\text{C}$ . In the case of  $\Delta T = 80^\circ\text{C}$ , the maximum expander power is 32 W, while the theoretical expander power was 67 W. This resulted in 48% maximum expander efficiency. The expander efficiency decreased to 43% in the case of  $\Delta T = 60^\circ\text{C}$ .

TABLE II AVERAGE EVAPORATOR AND CONDENSER PRESSURES

	Heat source temperature difference $\Delta T$ [ $^\circ\text{C}$ ]		
	60	70	80
Evaporator pressure: $P_E$ [MPa]	0.26	0.28	0.29
Condenser pressure: $P_C$ [MPa]	0.012	0.013	0.012
Pressure difference: $P_E - P_C$ [MPa]	0.25	0.26	0.28

TABLE III EXPANDER POWER AND EXPANDER EFFICIENCY

	Heat source temperature difference $\Delta T$ [ $^\circ\text{C}$ ]		
	60	70	80
Theoretical expander output: $\dot{W}_{T\_th}$ [W]	60.1	59.9	67.3
Measured max. expander output: $\dot{W}_T$ [W]	25.6	26.4	32.1
Measured max. expander efficiency: $\eta_T$ [%]	43.1	44.5	48.0

TABLE IV THERMAL EFFICIENCIES WITH AND WITHOUT PUMP POWER LOSS

	Heat Source temperature difference $\Delta T$ [ $^\circ\text{C}$ ]		
	60	70	80
Theoretical thermal efficiency: $\eta_{R\_th}$ [%]	8.85	8.72	9.41
Measured thermal efficiency without pump power loss: $\eta_{R1}$ [%]	3.81	3.88	4.52
Measured thermal efficiency with pump power loss: $\eta_{R2}$ [%]	3.07	3.14	3.82

Table IV lists the thermal efficiencies of the ORC system for  $\Delta T = 60^\circ\text{C}$ ,  $70^\circ\text{C}$ , and  $80^\circ\text{C}$  corresponding to the heat source temperature difference in Table III. In the case of  $\Delta T = 80^\circ\text{C}$ , the measured thermal efficiency with and without pump power loss was  $\eta_{R1} = 4.5\%$  and  $\eta_{R2} = 3.8\%$ , respectively, while the theoretical thermal efficiency was 9.4%. It can be seen that  $\eta_{R2}$  is less than half of the theoretical thermal efficiency. This reduction may be caused due to the following reasons: (i) The turbine efficiency was low mainly because of insufficient expansion. (ii) The pump power consumption was higher than expected (5 W). (iii) The heat loss from system components such as pipes and expander might have been larger because of inadequate insulation. In order to improve the efficiency of this system, these issues have to be resolved using low-cost solutions.

#### IV. CONCLUSION

In this study, a compact ORC system was developed using a compact rotary-vane-type expander for low-temperature waste heat recovery. HFC-245fa was employed as the working fluid. The following observations were made:

1. The measured efficiency of the rotary-vane-type expander was 43%, 44%, and 48% for a heat source temperature difference of  $\Delta T = 60^\circ\text{C}$ ,  $70^\circ\text{C}$ , and  $80^\circ\text{C}$ , respectively. The maximum expander power was 32 W in the case of  $\Delta T = 80^\circ\text{C}$ . A larger pressure difference between the expander inlet and outlet resulted in larger expander power.
2. The measured thermal efficiencies with pump power loss were 3.07%, 3.14%, and 3.82% for a heat source temperature difference of  $\Delta T = 60^\circ\text{C}$ ,  $70^\circ\text{C}$ , and  $80^\circ\text{C}$ , respectively, while the theoretical thermal efficiencies were 8.85%, 8.72%, and 9.41%. These efficiencies are not high enough for realizing an actual system.
3. Issues such as low expander efficiency, high pump power consumption, and lack of insulation must be resolved in order to improve the thermal efficiency of the proposed system.

#### REFERENCES

- [1] H. Nasu, "Waste heat quantity assumption from overall Japan industries," (in Japanese), Energy Conservation Center of Japan, *Press Release*, August 12, (1997).
- [2] T. Yamamoto, T. Furuhashi, N. Arai, and K. Mori, "Design and testing of the organic Rankine cycle," *Energy*, Vol. 26, (2001), pp. 239–251.
- [3] Free Power, "Introduction to Free Power ORC systems," June, (2005), (<http://www.freepower.co.uk>). Date of access: April 29, 2009.
- [4] H. Yamaguchi, X. R. Zhang, K. Fujima, M. Enomoto, and N. Sawada, "Solar energy powered Rankine cycle using supercritical  $\text{CO}_2$ ," *Applied Thermal Engineering*, Vol. 26, (2006), pp. 2345–2354.
- [5] N. Yamada, A. Hoshi, and Y. Ikegami, "Performance simulation of solar-boosted ocean thermal energy conversion plant," *Renewable Energy*, Vol. 34, (2009), pp. 1752–1758.
- [6] N. Inoue, T. Takeuchi, A. Kaneko, T. Uchimura, K. Irie, and H. Watanabe, "Development of electric power units driven by waste heat," *Transactions of the Japan Society of Refrigerating and Air Conditioning Engineers* (in Japanese), Vol. 22, (2005), pp. 357–368.
- [7] T. Saitoh, N. Yamada, and S.-I. Wakashima, "Solar Rankine cycle system using scroll expander," *Journal of Environment and Engineering*, Vol. 2, (2007), pp. 708–719.

- [8] NIST, "Reference Fluid Thermodynamic and Transport Properties Database (REFPROP) Version 8.0," U.S. Department of Commerce, Maryland, (2007).
- [9] O. Badr, P. W. O'Callaghan, and S. D. Probert, "Rankine-cycle systems for harnessing power from low-grade energy sources," *Applied Energy*, Vol. 36, (1990), pp. 263–292.

**Musthafah b. Mohd. Tahir** received his Bachelor of Engineering degree in Electrical Communication from the University of Tokyo, Japan in 1991 and his Master of Engineering degree from Nagaoka University of Technology (NUT), Niigata, Japan in 1997. Both in Mechanical Engineering. Currently, he is a PhD candidate at the Graduate School of Energy and Environment Science, NUT. He is also an academic staff of Malaysia University of Technical, Melaka (UTeM). His current research interest is energy recovery from waste heat.

**Noboru Yamada** received his doctorate in Engineering from the Department of Aeronautics and Space Engineering, Tohoku University, Japan in 1999. He is currently pursuing research in efficient utilization of solar energy (solar, thermal, and photovoltaic), energy storage systems (flywheel energy storage, thermal energy storage, etc.), and energy recovery from low-temperature heat.

Currently he is an Associate Professor in the Mechanical Engineering Department of NUT, Japan. The selected papers that he had published are N. Yamada, A. Hoshi, and Y. Ikegami, "Performance simulation of solar-boosted ocean thermal energy conversion plant," *Renewable Energy*, Vol. 34, (2009), pp. 1752–1758; Saitoh, T. S., Yamada, N., Ando, D., and Kurata, K., "A grand design of future electric vehicle to reduce urban warming and CO<sub>2</sub> emissions in urban area", *Renewable Energy*, Vol.30 (2005), pp.1847–1860; and Saitoh, T. S., Yamada, N., and Wakashima, S., "Study of Solar Organic Rankine Cycle System using Scroll Expander", *Trans. Japan Society of Mechanical Engineering*, Vol.71, No.703, Series B (2005), pp.242–248.

He is a member of The Japan Society of Mechanical Engineering (JSME), Heat Transfer Society of Japan, and International Solar Energy Society (ISES).