

Design of High Torque Elbow Joint for Above Elbow Prosthesis

Irfan Hussain, Adnan Masood, Javaid Iqbal, Umar S. Khan

Abstract—Above Elbow Prosthesis is one of the most commonly amputated or missing limbs. The research is done for modelling techniques of upper limb prosthesis and design of high torque, light weight and compact in size elbow actuator. The proposed actuator consists of a DC motor, planetary gear set and a harmonic drive. The calculations show that the actuator is good enough to be used in real life powered prosthetic upper limb or rehabilitation exoskeleton.

Keywords—Above Elbow prosthesis, Harmonic drive, Planetary gear set, Sagittal Plane

I. INTRODUCTION

PROSTHESIS is a device that is designed to replace, as much as possible, the function or appearance of a missing limb or body part. Worldwide, every year the number of amputees increases in 150,000 to 200,000 [1]. Advances in prosthesis had allowed people who lost an extremity to win back their normal life and live it with few limitations.

One of the forefronts in prosthetic technology is the upper limb above elbow prosthesis. But most of these include the Myo-electric hand and passive elbows. Myoelectric elbows can profitably substitute the passive ones, only if they can guarantee: durability, low noise, adequate torque, low power consumption, light weight, easy motion control and natural movements. Most of these objectives can be reached by good mechanical design and performance of the system highly depends by how it works [2]. Actuators usually selected for kinesthetic devices are either heavy (like direct drive electro-motors) or poor force actuators (like geared DC motors) [3].

In this study the actuator uses the harmonic drive for elbow joint actuation due to its several advantageous properties. It can give back to an actuator many of the qualities that are lost when gears, belt, ropes and chain drives are introduced.

Some characteristics of harmonic drives are high speed reduction ratio, free of backlash, high precision, small no of components and ease of assembly, small sized and light weight, high torque capacity, high efficiency and vibration free operation. Ideally prosthesis must be comfortable to wear, easy to put on and remove, lightweight, durable, and cosmetically pleasing. Furthermore, prosthesis must function well mechanically and require only reasonable maintenance.

I. Hussain is with Department of Mechatronics, National University of Sciences and Technology, Pakistan (e-mail: irfanmechatronics@gmail.com).

A. Masood is with Department of Mechatronics, National University of Sciences and Technology, Pakistan (e-mail: am34029@yahoo.com).

J. Iqbal is with Department of Mechatronics, National University of Sciences and Technology, Pakistan (e-mail: j.iqbal@ceme.nust.edu.pk).

U. S. Khan is with Department of Mechatronics, National University of Sciences and Technology, Pakistan (e-mail: umarshahbaz@gmail.com).

II. MAIN CHARACTERISTICS OF SOME MYO-ELECTRIC UPPER LIMB PROSTHESIS

A. Utah Arm

The characteristics of Utah arm are:

TABLE I
CHARACTERISTICS OF UTAH ARM

Characteristics	Utah Arm
Turntable Diameter	7.0 cm (2.8 in)
Arm weight	913 g
Hand weight	450 g
Maximum lift capacity	4.3 Nm
Passive (Locked) liftcapacity	68 Nm
Range of motion	0-135 deg
Operating temperature	0-44 centigrade
Locking positions	22
Speed....no load	112.5 degree/sec
Battery Type (Rechargeable control option)	12 V, Removable

B. NY Electric Elbow

The characteristics of NY Electric Elbow are:

TABLE II
CHARACTERISTICS OF NY ELECTRIC ELBOW

Characteristics	NY Electric Elbow
Turntable Diameter	7.1 cm (2.8 in)
weight	0.55 to 0.62 kg
Maximum lift capacity	3.4 Nm
Passive (Locked) liftcapacity	24.4 to 27.1 Nm
Range of motion	0-135 deg
Speed with counter torque	56.5 degrees/sec with counter torque of 1.7 Nm
Speed....no load	100 degrees/sec
Battery Type (Rechargeable control option)	5to5.25 non removable
Control	Myoelectric
Proportional	Yes
Time without recharge	8 hours
Recharge time	16 hours

C. Boston Elbow

The characteristics of Boston Elbow are:

TABLE III
CHARACTERISTICS OF BOSTON ELBOW

Characteristics	NY Electric Elbow
Turntable Diameter	7.3cm(2.9 in)
Weight	0.96 kg
Maximum lift capacity	5.9 Nm
Passive (Locked) liftcapacity	68 Nm
Range of motion	0-135 deg
Speed with counter torque	60.7 degrees/sec with counter torque of 1.4 Nm.
Speed....no load	123 degrees/sec
Battery Type (Rechargeable control option)	12V non removable
Control	Myoelectric
Proportional	Yes
Time without recharge	8 hours
Recharge time	2 hours

Besides these commercially available above elbow prosthesis, there are many elbow actuators that are under research and development in different institutions. A few of them are Politecnico di Milano prosthetic arm with an elbow mechanism constituted of two linkages in series: a crank and slotted link and a four bar linkage [2]. Cinvestav-IPN prosthetic arm which has a mechanism with four legs, one is fixed and other three are in parallel configuration consisting of linear actuators [4]. Tech. Innovation Society prosthetic arm has elbow transmission which is based on bevel gearbox [5].

III. MODEL OF THE HUMAN ARM

A basic model to study the motion and posture of the body can be obtained by describing the body as a linkage system. In this way arm can be divided in three links. The equations that describe the torque and forces on the shoulder joint for different position and movements of the arm in the sagittal plane are as shown in [6].

$$F_0 = \begin{bmatrix} F_{o1} \\ F_{o2} \end{bmatrix} = m_i \begin{bmatrix} \ddot{x}_{i1} \\ \ddot{x}_{i2} \end{bmatrix} + m_i \begin{bmatrix} 0 \\ g \end{bmatrix} \quad (1)$$

$$M_0 = \begin{bmatrix} L_{i1} \\ L_{i2} \end{bmatrix}^T = \begin{bmatrix} 0 & -1 \\ 1 & 0 \end{bmatrix} \begin{bmatrix} F_{o1} \\ F_{o2} \end{bmatrix} + J_i \ddot{\phi}_i \quad (2)$$

The dynamic analytical model that is analogous to actual anatomic system can be obtained by defining the human arm as two rigid segments connected to non-translating cylinder. The equations of motion for this dynamic system can be determined as shown in [7].

These modeling techniques can provide an initial theoretical understanding of an actual biodynamic system and help in the selection of the dynamic properties of the actual system to be measured.

IV. MECHANICAL DESIGN OF ELBOW DRIVE

The elbow drive consists of a DC motor, planetary gear set and harmonic drive. The motor is run by rechargeable batteries. The motor is connected to the planetary gear set which in turn are connected to the harmonic drive. Transmission design supplies a speed reduction between the motor and the elbow hinge that moves the forearm. The planetary gear set provides a gear reduction of 3:1 and the harmonic drive a reduction of 100:1. So the actuator provides the total ratio of 300:1. The block diagram of elbow drive is shown in Fig. 1.

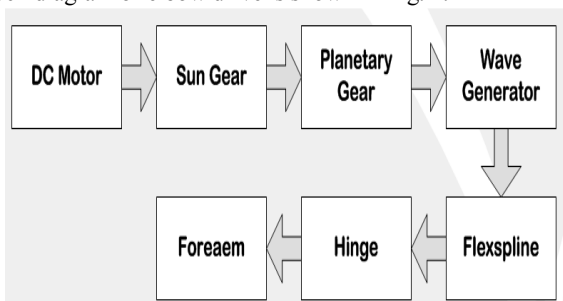

Fig. 1 Block diagram of elbow drive

The 3D model of the elbow actuator is given in Fig. 2.

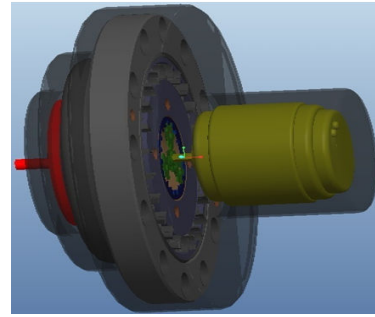

Fig. 2 3D model of the elbow actuator

V. PLANETARY GEAR SET

Planetary gearing is a gear system consisting of one or more outer gears, or planet gears, revolving about a central or sun gear.

Input: Sun Gear (S) = 6 teeth

Output: Ring Gear (R) = 18 teeth

Stationary: Planet Gear (P) = 6 teeth

Reduction Ratio = -3

VI. HARMONIC DRIVE

Harmonic drive gears, also called strain-wave gearing are compact, light weight and have torque ratios between 30:1 and 320:1, making them ideal for applications like prosthetics, exoskeletons and robotics. It has mainly three components: the wave generator (WG), the flexspline (FS) and the circular spline (CS), as shown in Fig. 3. The WG is an elliptical ball bearing assembly and is nested inside the FS. The teeth on the non rigid FS and the rigid CS are in continuous engagement. Since the FS has two teeth less than the CS, one revolution of the input causes relative motion between the FS and the CS equal to two teeth.

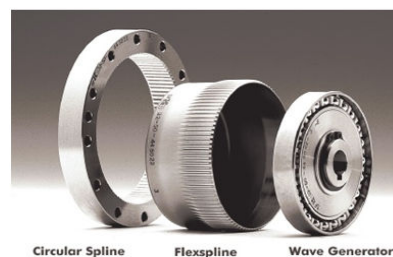

Fig. 3 Components of Harmonic Drive

In the elbow actuator the selected driving configuration is such that WG is input, FS is output and CS is fixed. With this arrangement the FS rotates in the opposite direction to the input at a reduction ratio equal to one-half the number of teeth on the FS. The displacement, velocity and torque relationships between the transmission elements in the ideal case are given in [8]. Harmonic Drive Rating table [9] gives the values of Rated torque (T_r), Limit for Repeated Torque, Limit for

Average Torque, Limit for Momentary Peak Torque, Maximum Input Speed, Limit for Average Input Speed and Moment of Inertia . Fig. 4 shows the Harmonic drive torque and speed ratings.

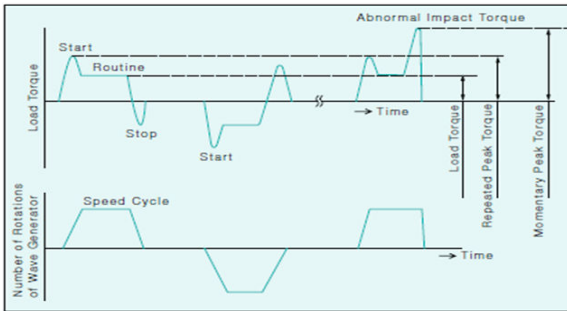

Fig. 4 Harmonic drive torque and speed ratings

A. Selection of Harmonic Drive

Generally, the operating conditions consist of fluctuating torques and output speeds. Also, an unexpected impact output torque must be considered. The proper size can be determined by converting fluctuating load torque into average load torque and equivalent load torque. This procedure involves selecting the size based on load torque for component set [9]. Fig. 5 shows fluctuating torque and corresponding output speed.

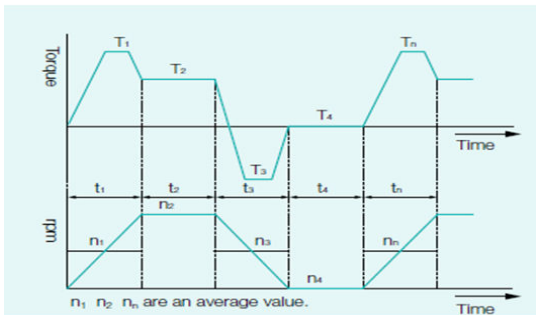

Fig. 5 Fluctuating Torques and output speed

- Values of an each load torque pattern:

Load Torque	T_n
Output Speed	n_n

$n_0 \text{ max} = 18.67 \text{ rpm}$
 $n_i \text{ max} = 1867 \text{ rpm}$
- Acceleration $T_1 = 6.9 \text{ Nm}$ $t_1 = 0.3 \text{ sec}$ $n_1 = 10 \text{ rpm}$
- Regular Operation Stop $T_2 = 5.49 \text{ Nm}$ $t_2 = 3 \text{ sec}$ $n_2 = 18.67 \text{ rpm}$
- Deceleration $T_3 = 3.43 \text{ Nm}$ $t_3 = 0.4 \text{ sec}$ $n_3 = 10 \text{ rpm}$
- Dwell $T_4 = 0 \text{ Nm}$ $t_4 = 0.2 \text{ sec}$ $n_4 = 0 \text{ rpm}$
- Impact $T_5 = 8.6 \text{ Nm}$ $t_5 = 0.15 \text{ sec}$ $n_5 = 18.67 \text{ rpm}$

$$T_{av} = \sqrt[3]{\frac{n_1 \times t_1 \times [T_1]^3 + n_2 \times t_2 \times [T_2]^3 + \dots + n_n \times t_n \times [T_n]^3}{n_1 \times t_1 + n_2 \times t_2 + \dots + n_n \times t_n}} \quad (3)$$

$$T_{av} = 5.448 \text{ Nm}$$

So by using the rating table given in [9]

$$T_{av} = 5.448 \text{ Nm} < 7.7 \text{ Nm}$$

This refers to the model CSD-14-100 of harmonic drive.

$$n_{0 \text{ av}} (\text{rpm}) = \frac{n_1 \times t_1 + n_2 \times t_2 + \dots + n_n \times t_n}{t_1 + t_2 + t_3 + \dots + t_n} \quad (4)$$

$$n_{0 \text{ av}} = 16.15 \text{ rpm}$$

$$\frac{1867 \text{ rpm}}{18.67 \text{ rpm}} = 100 \leq R(100) \quad (5)$$

$$n_{i \text{ av}} = n_{0 \text{ av}} \times 100 = 16.15 \times 100 = 1615 \text{ rpm} \quad (6)$$

$$n_{i \text{ max}} = 18.67 \times 100 = 1867 \text{ rpm} \quad (7)$$

The 'Limit for Average input Speed' of model CSD-14-100 is 6500 rpm [9]. It must be greater than calculated average input speed of the designed actuator.

$$n_{i \text{ av}} = 1615 \text{ rpm} < 6500 \text{ rpm} \quad (8)$$

The 'Maximum input Speed' of model CSD-14-100 is 14000 rpm [9]. Similarly it must be greater than calculated $n_{i \text{ max}}$.

$$n_{i \text{ max}} = 1867 \text{ rpm} < 14000 \text{ rpm} \quad (9)$$

Confirm if T_1 and T_3 are less than the repeated peak torque specification of CSD-14-100 given in [9].

$$T_1 = 6.9 \text{ Nm} < 19 \text{ Nm} \quad (10)$$

$$T_3 = 3.43 \text{ Nm} < 19 \text{ Nm} \quad (11)$$

Confirm if T_5 (impact torque) is less than the momentary peak torque specification of CSD-14-100 given in [9].

$$T_5 (\text{Nm}) = 8.6 \text{ Nm} < 31 \text{ Nm} \quad (12)$$

Calculate allowable number of rotations (N_s) during impact torque and confirm $N_s \leq 1.0 \times 10^4$

$$N_s = \frac{10^4}{2 \times \frac{n_s \times R}{60} \times t_s} \quad (13)$$

$$N_s = 1071.23 < 1.0 \times 10^4 \quad (14)$$

Calculate wave generator life

For oil lubrication $L_{10} > 7000$ [9]

$$L_n = L_n \times \left(\frac{T_r}{T_{av}}\right)^3 \times \left(\frac{n_r}{n_{iav}}\right) \quad (15)$$

$$L_{10} = 8258 > 7000 \quad (16)$$

Hence CSD-14-100 is suitable for speed and torque requirements of elbow actuator.

So (by considering standard component type), the selected model is CSD-14-100-2A-GR.

- [10] shows, technical parameters of selected brushed dc motor.
- [11] shows, features of rechargeable NiMH battery pack.
- [12] shows, features of multi-current universal smart charger.

VII. CHARACTERISTICS OF DESIGNED ELBOW ACTUATOR

The characteristics of designed elbow actuator are:

TABLE IV
CHARACTERISTICS OF DESIGNED ELBOW ACTUATOR

Characteristics	Elbow Actuator
Turntable Diameter	2.8 in
Weight	462 g
Speed...no load	18.67 rpm
Maximum lift capacity	5.49 Nm
Battery Type	12V, removable
Time without recharge	13 hours
Recharge time	2.4 hours

VIII. CONCLUSION

The field of prosthesis is indeed a human service and covers multi dimensional learning. Thus the proposed actuator is high torque, light weight and compact in size and good enough to be used in real life powered prosthetic upper limb or rehabilitation exoskeletons. After practical implementation of designed actuator, the results verification can be done with 'Human Arm Model' as discussed in [6.7]. Also the work can extend its horizons by modeling and designing actuator for shoulder joint or even for lower limb.

REFERENCES

- [1] C. Toledo, L. Leija, R. Muñoz, A. Vera and A. Ramírez, "Upper Limb Prostheses for Amputations Above Elbow: A Review", PAHCE. Conference, Workshops, and Exhibits. Cooperation Linkages-Pan American Health Care Exchanges 2009. J. Clerk Maxwell, A Treatise on Electricity and Magnetism, 3rd ed., vol. 2. Oxford: Clarendon, 1892, pp.68–73.
- [2] Federico Casolo, Simone Cinquemani and Matteo Cocetta, "Functional Design Of A Transmission For A Myoelectric Elbow Prosthesis", Proceedings of the World Congress on Engineering 2008 Vol III WCE 2008, London, U, July 2 - 4, 2008.
- [3] J.F. Veneman, R. Ekkelenkamp, R. Kruidhof, F.C.T. van der Helm, H. van der KooijR. "Design of a Series Elastic-and Bowdencable-based actuation system for use as torque- actuator in exoskeleton-type training "Proceedings of the 2005 IEEE, 9th International Conference on Rehabilitation Robotics, Chicago, IL, USA, June 28-July 1, 2005.
- [4] A.Z. Escudero, Ja. Álvarez, L. Leija, "Inverse Kinematics for a Parallel Myoelectric Elbow" Proceedings-23rd Annual Conference – IEEE/EMBS, Istanbul, TURKEY, Oct.25-28, 2001.
- [5] G.Thomann Sols, Solids, Structures Laboratory and V. Artigues, Tech.Innovation Evry, France, "Mechanical Design, Control Choices and first Return of Use of a Prosthetic Arm" 12th IFToMM World Congress, Besançon (France), June 18-21, 2007M. Young, The Technical Writer's Handbook. Mill Valley, CA: University Science, 1989.
- [6] V.M.L Vossen, "Evaluating the Boston Elbow, Weight distribution and motor friction experiment" Report of a practical training at the Liberty Mutual Research Center, Hopkinton, Massachusetts, USA, and Department of Biomedical Engineering, Eindhoven University of Technology the Netherlands.
- [7] Donald R. Peterson, Ronald S. Adrezin, BIODYNAMICS: A LAGRANGIAN APPROACH Standard Handbook of Biomedical Engineering and Design.
- [8] Christopher W. Kennedy and Jaydev P.Desai, "Estimation and modeling of the harmonic drive transmission in the Mitsubishi PA-10 robot arm", Program for Robotics, Intelligent Sensing and Mechatronics (PRISM) Laboratory, Drexel University, Philadelphia, PA 19104, USA.
- [9] Cup type component sets and housed units, Harmonic drive gear, Precision Gearing and Motion Control. [Online] Available: http://www.harmonicdrive.de/cms/upload/pdf/GK2007/Katalog_Catalogue_Catalogo_0708.pdf
- [10] DC motor, Model: RF 370CA.[Online] Available: http://www.kinmoremotor.com/product_disp.php?productid=23&weblan=e
- [11] NiMH Battery Pack: 12 V 2200mAh (10xAA) for Walking Robot. [Online] Available: <http://www.batteryspace.com/nimhbatterypack12v2200mah10xaaforwalkingrobot.aspx>
- [12] Multi-Current universal smart charger. [Online] Available: <http://www.batteryspace.com/multi-currentuniversalsmartchargerfor96v-18v-nimhbattery-pack-stamiyaplug-listed.aspx>