

Prediction the Deformation in Upsetting Process by Neural Network and Finite Element

H.Mohammadi Majd, M.Jalali Azizpour , Foad Saadi

Abstract—In this paper back-propagation artificial neural network (BPANN) is employed to predict the deformation of the upsetting process. To prepare a training set for BPANN, some finite element simulations were carried out. The input data for the artificial neural network are a set of parameters generated randomly (aspect ratio d/h , material properties, temperature and coefficient of friction). The output data are the coefficient of polynomial that fitted on barreling curves. Neural network was trained using barreling curves generated by finite element simulations of the upsetting and the corresponding material parameters. This technique was tested for three different specimens and can be successfully employed to predict the deformation of the upsetting process

Keywords—Back-propagation artificial neural network (BPANN), prediction, upsetting

I. INTRODUCTION

RECENTLY, there have been some applications of modeling the upsetting process by means of neural networks. In most of the previous works, trained networks predict only flow stress and metal behavior [1]-[3]. In this work, a neural network model is coupled with a two-dimensional finite element analysis to predict deformation in upsetting process. In this way, the barreling curve can be determined for different kinds of aspect ratio d/h , material properties, temperature and coefficient of friction by finite element analysis, using ANSYS software.

The employed finite element analysis is capable of considering the effects of various parameters. These results then be used to training the neural network. The validity of the model is then tested by comparing the model predictions and the experimental results of upsetting experiments [4].

II. UPSETTING PROCESS

Among the processes of metal forming, upsetting has great significance for metal forming since it represents a basic process which can be varied in many ways and it is usually used for generating the material parameters of metals under hot working condition. During the upsetting process, barreling

occurs due to the friction between the work piece and the die surfaces (Fig.1). The existence of this frictional constraint directly affects the plastic deformation of the work piece.

Various factors affect the deformation of work piece in upsetting process, major factor to be considered are the aspect ratio d/h , material properties, temperature and coefficient of friction.

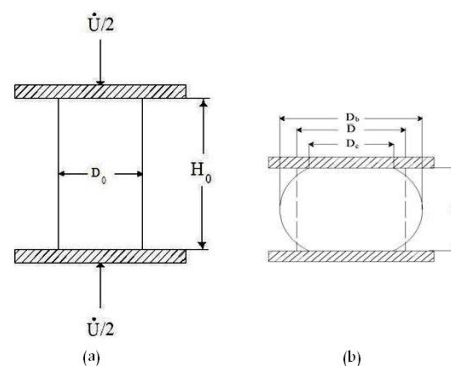

Fig.1 Schematic of deep upsetting process

III. FINITE ELEMENT SIMULATION

There are numerous influencing parameters, but according to the experimental and simulation results, the primary ones are aspect ratio (d/h), material properties, temperature and coefficient of friction. Through 38 sets of finite element analysis under different working condition the input data achieved (Table.1). At the same time in order to confirm the validity of the neural network model, an extra three simulation are carried out under different condition from the above 38 sets (Table.2). Because of the existing symmetry, only one quarter of the work piece is considered in the modeling (Fig.2). The tooling surface of die was modeled using rigid- body model. The finite element is utilized using Anand model for viscoplastic materials, as follows:

$$\dot{\sigma} = \left\{ h_0 \left(\frac{B}{|B|} \right)^a \frac{B}{|B|} \right\} d^p \quad (1)$$

$$d^p = A e^{\frac{-Q}{R\theta}} \left[\sinh \left(\xi \frac{\sigma}{s} \right) \right]^{\frac{1}{m}} \quad (2)$$

H.Mohammadi Majd is with the Islamic Azad University, Ahwaz Branch. Iran. Corresponding author to provide phone: +989163009885; e-mail: majd_ha@yahoo.com).

M.Jalali Azizpour is with the Islamic Azad University, Ahwaz branch. Iran. (corresponding author to provide phone: +986113358491; fax: +986113358490; e-mail: m_jpour@yahoo.com).

Foad Saadi is with the Islamic Azad University, Ahwaz Branch. Iran. (Corresponding author to provide phone: +986113324433; Fax: +986112236752; e-mail: foad.saadi320@gmail.com).

$$B = 1 - \frac{s}{s^*} \tag{3}$$

$$s^* = \hat{s} \left[\frac{d^p}{A} e^{\frac{Q}{R\theta}} \right]^n \tag{4}$$

Compares the deformation obtained by FEM simulation with that obtained experimentally [4], proving that the model proposed herein is accurate in determining the deformation of upsetting process.

TABLE I
FEM SIMULATION CONDITION

Material properties	$\frac{d}{h}$ d=30 (mm)	T(oC) temperatur e	m Friction coefficient
E =207 Gpa σ_0 =1860 Mpa	1	400	0.2
	1.2	700	0.4
	1.5		
E =190 Gpa σ_0 =245 Mpa	1	400	0.2
	1.2	700	0.4
	1.5		
E = 71 Gpa σ_0 =100 Mpa	1	400	0.2
	1.2	700	0.4
	1.5		

IV. NEURAL NETWORKS

An artificial neural network is a parallel distributed information processing system. It stores the samples with distributed coding, thus forming a trainable nonlinear system. The main idea behind a neural network approach resembles the human brain functioning. Given the input and the expected outputs, the program is self adaptive to the environment so as to respond to different inputs rationally. The objective of this paper is to investigate the prediction of deformation in upsetting process, by training a BPANN. The neuron can be classified into three types: input, output, hidden neurons. Input neurons are the ones that receive input from the environment, such as aspect ratio d/h, material properties, temperature and coefficient of friction in this study. Output neurons are those that send the signals out of the system, like five coefficient of polynomial that fitted on barreling curves. As the activation function, Sig activation function has been used, which is

continuous, nonlinear, monotonic non-decreasing and S shaped function (5).

$$f(x) = \frac{1}{1 + e^{-\beta x}} \tag{5}$$

TABLE II
.TEST CONDITION

	E (GPa)	σ_0 (MPa)	$\frac{d}{h}$	T(c)	m
Specimen1	207	1860	1.5	673	0.3
Specimen1	207	1860	1.5	773	0.2
Specimen1	200	490	1.36	773	0.2

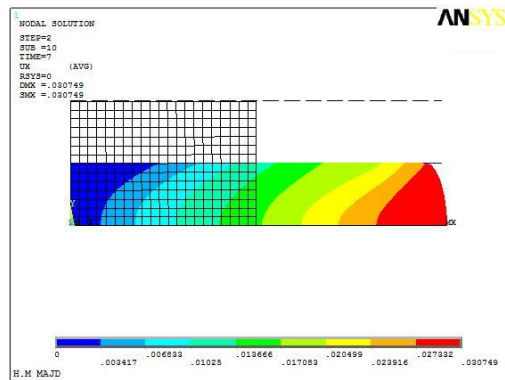

Fig.2 FEM simulation

In this study, the back propagation, which is a widely used algorithm, is used in the training step. Back propagation is a systematic method for training multilayer artificial neural networks. It has a strong mathematical foundation based on gradient descent learning. Elman BP network train with the back propagation algorithm is used. Elman networks are back propagation networks, with the addition of a feedback connection from the output of the hidden layer to its input. This feedback path allows Elman networks to learn to recognize and generate temporal patterns, as well as spatial patterns [5]. For an Elman to have the best chance at learning a problem it needs more hidden neurons in its hidden layer than are actually required for a solution by another method. This model has four layers including, an input layer, two hidden layer and an output layer. In this work, different number of hidden units has been employed to obtain the optimum number of hidden units. The experiments show that number of 16 units in the hidden layer is enough to reach the desired accuracy (Table.3).

TABLE III COMPARISON OF MEAN SQUARE ERROR USING DIFFERENT STRUCTURE OF ANN

Structure of ANN	MSE Mean square error
5-5-5-5	0.000025416
5-8-8-5	2.72e-7
5-10-10-5	0.0000127
5-12-12-5	0.001287
5-15-15-5	3.653e-9
5-16-16-5	2.854e-10
5-18-18-5	3.246e-6
5-20-20-5	0.0254

Fig.3 shows the structure of the employed network where the 38 data sets were used for training the network.

Training of the neural network was done in MATLAB, using Sig and TRAINLM function. TRAINLM is a network training function that updates weights and bias values in a back propagation algorithm according to Levenberg–Marquardt optimization. Levenberg–Marquardt algorithm is a highly efficient method for solving non-linear optimization problems[6], [7]. The trained network model showed error of 1.78%, 2.39% and 8.42% while testing with the 3 data sets. Fig.4 shows comparison of the predicted barreling curve during upsetting with finite element method and artificial neural network.

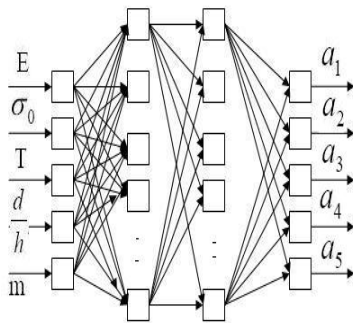
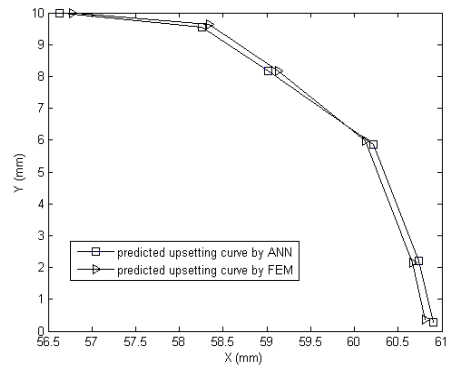
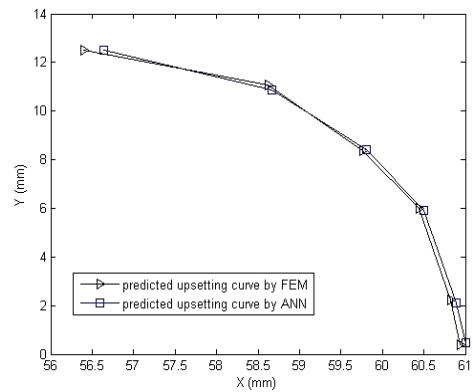

Fig.3 The structure of the neural network



(a)



(b)

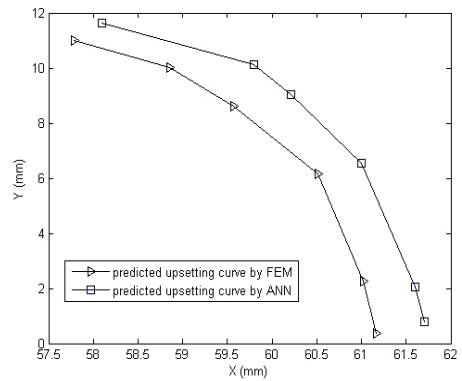

(c)

Fig.4 Shows comparison of the predicted barreling curve during upsetting with fem and ann, a) specimen1, b) specimen2, c) specimen3

V. CONCLUSION

In this work a four-layer back propagation network is developed to best fit this nonlinear engineering problem. Through comparison between the targeted value and training results with different neuron numbers in the hidden layers, an appropriate number of 16 is suitable to set up this network. For this nonlinear engineering problem, the appropriate algorithm is Levenberg-Marquardt because it can reach high

accuracy. The error between the predicted value and targeted one is little. Using this network can save much time.

REFERENCES

- [1] N. Selvakumar, P. Ganesan, P. Radha, R. Narayanasamy, and K.S. Pandey, "Modelling the effect of particle size and iron content on forming of Al-Fe composite preforms using neural network", *Materials & Design*, Volume 28, Issue 1. 2007, Pages 119-130
- [2] Siamak Serajzadeh, "Prediction of temperature distribution and required energy in hot forging process by coupling neural networks and finite element analysis", *Materials Letters* Volume 61, Issues 14-15
- [3] Siamak Serajzadeh "Prediction of thermo- mechanical behavior during hot upsetting using neural networks" *Materials Science and Engineering in press* 2008, Pages 140-147
- [4] Zhihong Huang, Margaret Lucasa, Michael J. Adam Modelling wall boundary conditions in an elasto-viscoplastic material forming process *Journal of Materials Processing Technology* 107 (2000) 267-275.
- [5] Elman, J. L., "Finding structure in time", *Cognitive Science*, vol. 14, pp.179-211,1990
- [6] j.SI," theory and application of supervised learning method based on gradient algorithms", *J tsinghua univ.* vol 37,1997
- [7] M.T.HAGEN,"training feed forward network with the levenberg-marquardt algorithm", *IEEE*, pp 989-993, 1994.