

Design of a Permanent Magnet Synchronous Machine for the Hybrid Electric Vehicle

Arash Hassanpour Isfahani, and Siavash Sadeghi

Abstract—Permanent magnet synchronous machines are known as a good candidate for hybrid electric vehicles due to their unique merits. However they have two major drawbacks i.e. high cost and small speed range. In this paper an optimal design of a permanent magnet machine is presented. A reduction of permanent magnet material for a constant torque and an extension in speed and torque ranges are chosen as the optimization aims. For this purpose the analytical model of the permanent magnet synchronous machine is derived and the appropriate design algorithm is devised. The genetic algorithm is then employed to optimize some machine specifications. Finally the finite element method is used to validate the designed machine.

Keywords—Design, Finite Element, Hybrid electric vehicle, Optimization, Permanent magnet synchronous machine.

I. INTRODUCTION

SELECTION of traction machines for hybrid electric vehicles (HEVs) is important and needs to get enough attention. The major requirements of HEVs electric machines are as follows [1]:

- 1- High instant power and high power density
- 2- High torque at low speed and a high power at high speed
- 3- Wide speed range
- 4- Fast torque response
- 5- High efficiency over the wide speed and torque ranges
- 6- High efficiency for regenerative braking
- 7- Reliability and robustness
- 8- Reasonable cost

Different machines have been used in HEVs so far. Induction machines, permanent magnet machines, DC machines and switch reluctance machines are the most applicable machines [1, 2]. Induction machines are the most interesting machines for HEVs up to now. Whereas, permanent magnet synchronous machines (PMSMs) are the most capable competing with induction machines for the electric machines of HEVs. This is due to their many advantages including high efficiency, compactness, high power density, fast dynamics and high torque to inertia ratio. Interior permanent magnet (IPM) machines with extra features

of mechanical robustness, capability of flux weakening and high speed operation are particularly suitable as electric machines of HEVs.

Different topologies of PM machines are available e.g. radial flux machines, axial flux machines and transversal flux machines. The transversal flux machine is a relatively recent developed machine type particularly suited for direct drive i.e. high torque and relatively low speed [3]. Axial flux machines have been used in the both low speed direct drive and high speed flywheel applications. Radial flux machines have been also considered for HEVs.

Proper performance of PMSMs are greatly depends on their optimal design and control. Optimal design of PMSMs for HEV application has been considered in many researches so far. Consumed magnet material, back EMF shape, compactness, torque and efficiency are the major aims of optimizations [4-8].

In spite of benefits and well suited characteristics of PMSMs for HEV application, they suffer from two major drawbacks i.e. high cost and small constant power region. High price of these machines is mainly due to the cost of permanent magnets. The maximum speed of PMSMs is usually limited by out put power. This feature may be a problem in HEVs in high speed operations. In this paper an interior type PMSM is optimized from mentioned points of views i.e. cost and maximum speed. To do this, analytical model of PMSM is employed and constant power region width and the cost of motor are evaluated and then are optimized using genetic algorithm method. Finally time stepping finite element method is employed to check the validity of proposed method.

II. MACHINE MODEL

Interior typed permanent magnet (IPM) machines are proposed in different configurations; among them the machine with tangential magnet poles enjoys many features including structural simplicity, mechanical robustness, good flux weakening capability and wide speed range. These features made it a preferred choice for many researchers and manufacturers. Therefore this configuration of IPM machines is also chosen in this paper for design optimization. A one pole pitch cross sectional view of a 6-pole IPM machine with tangential magnet configuration is shown in Fig.1. The figure mainly details the rotor configuration and dimensions as the stator is usually the same as stator of an induction machine

Manuscript received December 19, 2007.

A. Hassanpour Isfahani is with the Engineering Faculty, Islamic Azad University, Khomeinishahr Branch, Isfahan, Iran. He is also a PhD student of University of Tehran, Tehran, Iran. (Phone: +98-913-3175753; e-mail: ahassanpour@ieee.org).

S. Sadeghi is with the Islamic Azad University, Natanz Branch, Isfahan, Iran. (email:sadeghiaut@yahoo.com).

and is not the focus of the present design optimization.

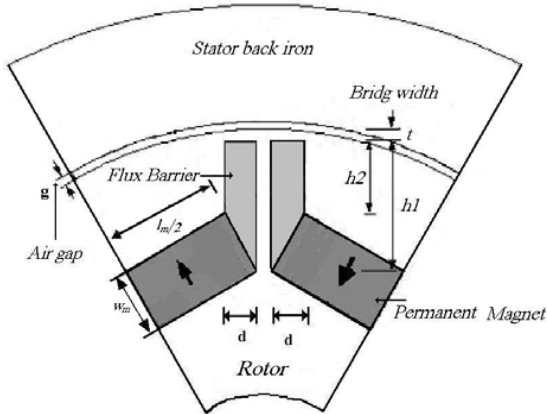

Fig. 1 One pole pitch cross section of IPM Machine

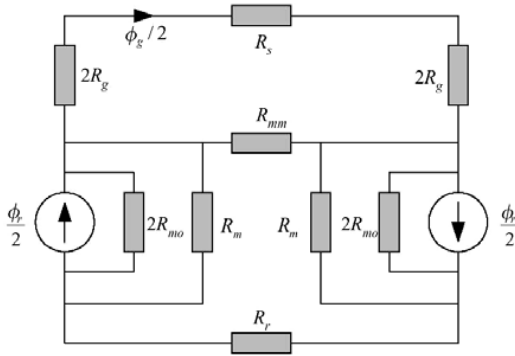

Fig. 2 Magnetic equivalent circuit of PMSM

A pair of half magnet poles, two flux barriers, stator and rotor cores and air gap can be seen in Fig. 1. A magnetic model and an electrical model of the machine are recalled in this section to calculate parameters and variables of the machine needed for a design optimization.

A. Magnetic Model

Magnetic equivalent circuit of one pole pitch of IPM machine is shown in Fig. 2.

A detailed magnetic equivalent circuit of the motor in Fig. 1 can be used to obtain an average air gap flux density as [9]:

$$B_g = \frac{C_\Phi}{1 + \beta(1 + 2\eta + 4\lambda)} B_r \quad (1)$$

where B_r is remanence of the magnet, $C_\Phi = A_m/A_g$ is the flux concentration factor and A_g and A_m are the cross-sectional areas per pole of the air gap and magnet respectively.

The magnetic reluctances of stator and rotor cores are ignored for the sake of simplicity. The values of parameters in

(1) are given by:

$$\beta = \frac{\mu_{rec} K_C g C_\Phi}{w_m} \quad (2)$$

$$\eta = \frac{w_1(h_1 + h_2)}{4d\mu_{rec}l_m} \quad (3)$$

$$\lambda \cong \frac{1 + \frac{1}{2\eta}}{\beta} \quad (4)$$

$$2 \frac{A_m B_r}{A_{mm} B_s} - 4$$

where g is the air gap length, K_C is the Carter coefficient, μ_{rec} is relative recoil permeability and $A_{mm} = t.l$ represents the cross-sectional area of the iron bridge above the nonmagnetic barriers with t and l being the bridge width and motor stack length, respectively. Also l_m and w_m denote the magnet length and width; and h_1 and h_2 represent the inner and the outer flux barrier heights respectively, while B_s is a limit of the leakage flux density in the bridge due to saturation.

Using B_g from (1) in connection with (2)-(4), the maximum value of first harmonic of PM flux linkage is obtained as [9]:

$$\Psi_M = \frac{4DI}{\pi} \left(\frac{K_{w1} N_{ph}}{P} \right) B_g \sin\left(\frac{\alpha\pi}{2}\right) \quad (5)$$

where K_{w1} is the winding factor, N_{ph} is the winding turns per phase and P is the number of pole pairs and α is a pole-arc to pole pitch ratio. Also D is the inner diameter of the stator. The d -axis and q -axis inductances are given by:

$$L_d = \frac{3\mu_0 DI}{g} \left(\frac{K_{w1} N_{ph}}{P} \right)^2 \frac{\pi}{8} K_d \quad (6)$$

$$L_q = \frac{3\mu_0 DI}{g} \left(\frac{K_{w1} N_{ph}}{P} \right)^2 \frac{\pi}{8} K_q \quad (7)$$

where K_d and K_q are defined as:

$$K_d = \left(\alpha - \frac{\sin(\alpha\pi)}{\pi} \right) + \frac{g}{g_e} \left(1 - \alpha + \frac{\sin(\alpha\pi)}{\pi} \right) \quad (8)$$

$$K_q = \left(\alpha + \frac{\sin(\alpha\pi)}{\pi} \right) + \frac{g}{g_e} \left(1 - \alpha - \frac{\sin(\alpha\pi)}{\pi} \right) \quad (9)$$

and g_e denotes an effective air gap and is given by:

$$g_e = K_C g \quad (10)$$

with μ_r being the relative permeability of PM.

B. Electrical Model

A conventional d - q electrical model of the machine in a

synchronously rotating reference frame can be used in design optimization and evaluation. In this model the flux distribution in the air gap is assumed to be sinusoidal and the iron loss and magnetic saturation are not considered.

The motor vector diagram is shown in Fig. 3. Voltage equations are expressed as follows:

$$V \sin(\delta) = i_d R_1 + \omega i_q L_q \quad (11)$$

$$V \cos(\delta) = i_q R_1 - \omega i_d L_d + E_f \quad (12)$$

The motor torque is then obtained as:

$$T = \frac{3P}{2} (\psi_M + (L_d - L_q) i_d) i_q \quad (13)$$

where i_d and i_q are the d -axis and q -axis components of the stator current vector I_s .

Thus the magnitude of I_s is given by:

$$I_s = \sqrt{i_d^2 + i_q^2} \quad (14)$$

Since an IPM motor torque depends on the stator current vector components as well as the motor parameters, the design optimization is carried out under the condition of maximum torque per Ampere control. This condition can be as obtained from (11) and (12) as follows [10]:

$$i_d = \Gamma - \sqrt{\Gamma^2 + \frac{I_s^2}{2}} \quad (15)$$

$$i_q = \sqrt{I_s^2 - i_d^2} \quad (16)$$

Where

$$\Gamma = \frac{\psi_M}{4L_d} (\rho - 1) \quad (17)$$

$$\rho = \frac{L_q}{L_d} \quad (18)$$

Flux linkage and inductances can be normalized as follows:

$$\psi_M^* = \sqrt{(L_q i_q^*)^2 + (\psi_M + L_d i_d^*)^2}, \quad L^* = \frac{\psi_M}{I_{\max}} \quad (19)$$

$$L_{dn} = \frac{L_d}{L^*}, \quad L_{qn} = \frac{L_q}{L^*}, \quad \psi_{Mn} = \frac{\psi_M}{\psi_M^*} \quad (20)$$

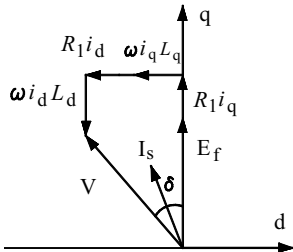

Fig. 3 Vector diagram of PMSM

III. OPTIMIZATION PROBLEM

As mentioned above, maximum speed and cost of motor is chosen for optimization. The price of permanent magnet is very high in comparison with other material of PMSM. Therefore we can approximately use consumed magnet volume instead of motor cost.

The variation of normalized power as the term of normalized angular speed is depicted in Fig. 4 for different conditions of motor. These conditions are as follows [11]:

$$a) \frac{\psi_{Mn}}{L_{dn}} > 1, \quad b) \frac{\psi_{Mn}}{L_{dn}} = 1, \quad c) \frac{\psi_{Mn}}{L_{dn}} < 1 \quad (21)$$

For HEV applications the case of b is the best case. Therefore in the optimization we should keep normalized flux linkage to normalized direct inductance close to one.

To obtain optimal design considering both power factor and efficiency, the objective function is defined as follows:

$$\tau = \left(\frac{\psi_{Mn}}{L_{dn}} - 1 \right)^m \cdot (V_{PM})^n \quad (22)$$

As seen in (22), the importance of both objectives are adjusted by power coefficient respect to desirable performance. This importance can be supposed to be equal by using the same value for power coefficient.

Minimization of τ fulfils simultaneously both objectives of the optimization. Such an objective function provides a higher degree of freedom in selecting appropriate design variables. Genetic algorithm is employed to search for minimum value of τ .

Genetic algorithm provides a random search technique to find a global optimal solution in a complex multidimensional search space [12]. The algorithm consists of three basic operators i.e. selection, crossover and mutation. First an initial population is produced randomly.

Then genetic operators are applied to the population to improve their fitness gradually. The procedure yields in new population at each iteration.

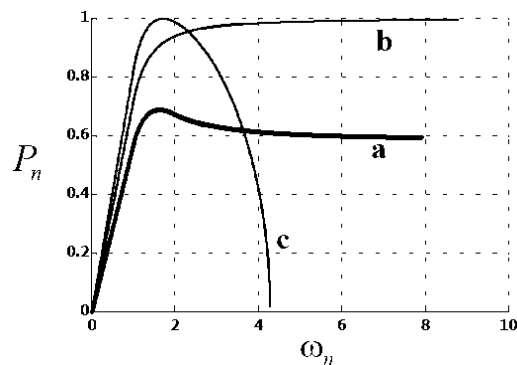

Fig. 4 The variation of normalized power with normalized angular speed [11]

Fig. 5 shows the flow chart of genetic algorithm. In this paper Roulette wheel method is used for selection and at each step elite individual is sent directly to the next population.

A PMSM is chosen as the basis of design optimization. The specification of this motor are listed in Table I.

Some of the PMSM parameters and dimensions are selected as design variables. Design variables are determined through a design optimization procedure.

In this paper, design variables are magnet dimensions, motor stack length, flux barrier dimensions and number of phase winding turns.

The rated torque, the input voltage, the input frequency, and the pole pitch are main constant specifications in the design procedure.

Optimization is done using $n=m=1$. Dimensions of optimized motor are listed in Table II.

The results of optimization are also seen in Table III.

It is seen that the magnet volume reduces 8.8% and Ψ_{Mn}/L_{dn} is closer to unit that typical machine.

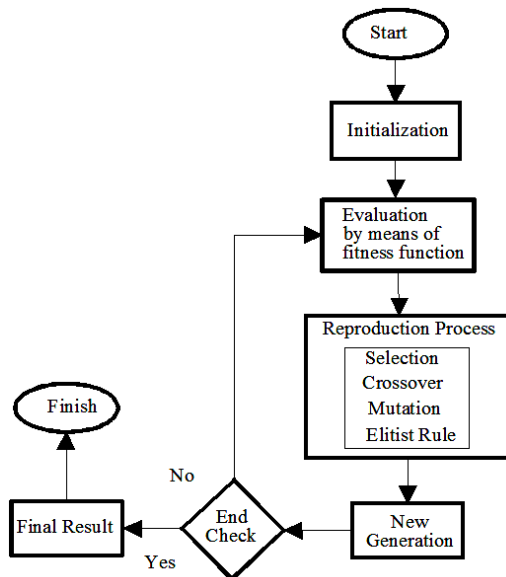

Fig. 5 The flowchart of genetic algorithm method

IV. FINITE ELEMENT EVALUATION

The design optimization in this work is carried out based on the analytical magnetic and electrical models of machine presented in section 2. Therefore, the validity of the design optimization depends on the accuracy of the models. The models accuracy is evaluated in the present section by a FEM analysis.

The evaluation is carried out by a comparison of the optimized motor parameters obtained by the analytical models and the FEM analysis. A 2-D FEM analysis is carried out and the numerical and graphical results are obtained. Fig. 6 shows the flux lines due to the PM rotor poles. The corresponding FEM numerical results are used to calculate the motor parameters and torque. These are shown in Table IV.

TABLE I
SPECIFICATION OF TYPICAL MACHINE

Symbol	Quantity	Value
r_1	Stator bore radius	47.5 mm
g	Air gap length	1.00 mm
t	Bridge width	1.50 mm
d	Flux barrier width	4.00 mm
h_1	Flux barrier height	15.9 mm
h_2	Flux barrier height	8.9 mm
w_m	Magnet width	8.1 mm
l_m	Magnet length	27.7 mm
B_r	Remanence	1.05 T
B_s	Saturation flux density	1.88 T
μ_{rec}	Recoil permeability	1.05
P	Number of pole pairs	3
f	Frequency	360 Hz
I_N	Rated current	19 A
N_{ph}	Series turns per phase	30
K_{wt}	Winding factor	0.644
l	Machine stack length	90 mm

TABLE II
SPECIFICATION OF OPTIMIZED MACHINE

Symbol	Quantity	Value
h_1	Flux barrier height	13.1 mm
h_2	Flux barrier height	7.2 mm
w_m	Magnet width	7.1 mm
l_m	Magnet length	23.8 mm
N_{ph}	Series turns per phase	34
l	Machine stack length	109 mm

TABLE III
COMPARISON OF TYPICAL AND OPTIMIZED MACHINE

Specification	Typical machine	Optimized machine
Torque	6.41 Nm	6.38 Nm
Magnet volume	20.2 cm ³	18.4 cm ³
$\frac{\Psi_{Mn}}{L_{dn}}$	0.84	0.98

TABLE IV
FEM AND ANALYTICAL RESULTS COMPARISON

Specification	Analytical	FEM
Torque	6.38 Nm	6.24 Nm
L_d	0.08 mH	0.07 mH
L_q	0.12 mH	0.11 mH

It is seen that the error is less than 5% in the motor torque. The torque error can also be due to ignoring iron loss in electrical model. Therefore, it can be concluded that the analytical models are reasonably adequate to prove the effectiveness of the design optimization.

However, to achieve a more accurate design optimization, a more detailed magnetic and electrical model of IPM machines is required. Such models may consider magnetic saturation in other parts of the machine, flux harmonics and iron loss.

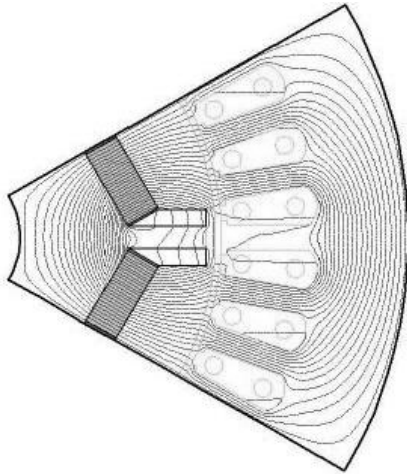

Fig. 6 Flux lines at no-load condition

V. CONCLUSION

In this paper an optimal design of a permanent magnet machine has been presented.

A reduction in the permanent magnet material for a constant torque and an extension in the constant power region have been chosen as the optimization aims. For this purpose the analytical model of the permanent magnet synchronous machine has been derived.

The genetic algorithm was then employed to optimize some machine specifications. It was seen that with the same developed torque the magnet volume decrease about 9% and also the power speed characteristic was going to be better than typical machine.

Finally the finite element method was used to validate the optimized machine. Comparison of results shows the validity of analytical design.

REFERENCES

- [1] M. Zeraouia, and *et al*, "Electric motor drive selection issues for HEV propulsion systems: A comparative study," *IEEE Trans. Vehicular Tech.*, vol. 55, pp.1756-1763, Nov. 2006.
- [2] L. Chang, "Comparison of ac drives for electric vehicles- A report on experts' opinion survey," *IEEE AES Systems Magz.* pp.7-10, Aug. 1994.
- [3] T. Backstrom, Integrated energy transducer drive for hybrid electric vehicles, PhD Thesis, Royal Institute of Technology, Sweden, 2000.
- [4] C. Mi, "Analytical design of permanent-magnet traction-drive motors," *IEEE Trans. Magn.*, vol. 42, pp. 1861-1866, July, 2006.
- [5] Y. Fujishima, S. Vakao, M. Kondo, and N. Terauchi, "An optimal design of interior permanent magnet synchronous motor for the next generation commuter train," *IEEE Trans. Applied Superconductivity*, vol. 14, pp. 1902-1905, June 2004.
- [6] F. Magnussen, P. Thelin, and C. Sadarangani, "Design of compact permanent magnet machines for a novel HEV propulsion system," in *Proc. 20th Int. Electric Vehicle Symposium and Exposition*, Long beach, California, USA, 15-19 Nov., 2003, pp. 181-191.
- [7] S. Wu, L. Song, and S. Cui, "Study on improving the performance of permanent magnet wheel motor for the electric vehicle application," *IEEE Trans. Magn.*, vol. 43, pp. 438-442, Jan 2007.
- [8] Y. K. Chin, J. Soulard, "A permanent magnet synchronous motor for traction applications of electric vehicles," Royal Institute of Tech., available online.
- [9] C.C. Hwang, S.M. Chang, C.T. Pan, T.Y. Chang, "Estimation of Parameters of Interior Permanent Magnet Synchronous Motors," *J. Magnetism and Magnetic Materials*, pp. 600-603, 2002.
- [10] S. Vaez-Zadeh, A.R. Ghasemi, "Design Optimization of Permanent magnet Synchronous Motors for High Torque Capability and Low Magnet Volume," *Electric Power Systems Research*, Vol.74, pp. 307-313, Mar. 2005.
- [11] S. Vaez-Zadeh, M. Tavakkoli, "Optimal design of permanent magnet synchronous motor from two points of view: Infinite maximum speed and extended constant torque region," in *Proc. 11th Iranian electrical engineering conf.*, ICEE, Shiraz, May 2003, vol. 4, pp. 231-239. (in Persian).
- [12] D. E. Goldenberg, *Genetic algorithm in search, optimization and machine*, Massachusetts, Addison Wesley 1989.

Aarsh Hassanpour Isfahani was born in Isfahan, Iran, in 1980. He received a B.Sc. degree in electrical engineering from Isfahan University of Technology, Isfahan, Iran in 2002 and a M.Sc. degree in electric power engineering (electrical machines) from university of Tehran, Tehran, Iran in 2005 where he is a PhD student now. His research interests include design, modeling and control of electrical machines.

Siavash Sadeghi was born in Isfahan, Iran, in 1980. He received a B.Sc. degree in electrical engineering from Isfahan University of Technology, Isfahan, Iran in 2003 and a M.Sc. degree in electric power engineering (electrical machines) from Amirkabir university of Technology, Tehran, Iran in 2006. He is with Islamic Azad university, Natanz Branch, as a lecturer now. His research interests include control of electrical machines, hybrid electric vehicles and gas insulated lines.