

Advantages of Large Strands in Precast/Prestressed Concrete Highway Application

Amin Akhnoukh

Abstract—The objective of this research is to investigate the advantages of using large-diameter 0.7 inch prestressing strands in pretension applications. The advantages of large-diameter strands are mainly beneficial in the heavy construction applications. Bridges and tunnels are subjected to a higher daily traffic with an exponential increase in trucks ultimate weight, which raise the demand for higher structural capacity of bridges and tunnels. In this research, precast prestressed I-girders were considered as a case study. Flexure capacities of girders fabricated using 0.7 inch strands and different concrete strengths were calculated and compared to capacities of 0.6 inch strands girders fabricated using equivalent concrete strength. The effect of bridge deck concrete strength on composite deck-girder section capacity was investigated due to its possible effect on final section capacity. Finally, a comparison was made to compare the bridge cross-section of girders designed using regular 0.6 inch strands and the large-diameter 0.7 inch. The research findings showed that structural advantages of 0.7 inch strands allow for using fewer bridge girders, reduced material quantity, and light-weight members. The structural advantages of 0.7 inch strands are maximized when high strength concrete (HSC) are used in girder fabrication, and concrete of minimum 5ksi compressive strength is used in pouring bridge decks. The use of 0.7 inch strands in bridge industry can partially contribute to the improvement of bridge conditions, minimize construction cost, and reduce the construction duration of the project.

Keywords—0.7 Inch Strands, I-Girders, Pretension, Flexure Capacity.

I. INTRODUCTION AND LITERATURE REVIEW

THE percentage of structurally deficient bridges within the United States National Bridge Inventory (NBI) is more than 10% according to recent studies, excluding railroad bridges. Structural deficient bridges include all bridges with severe deterioration in one or more of the bridge structural components (i.e. bridge substructure, bridge superstructure, or bridge deck). The deterioration is enough to reduce the load carrying capacity of the bridge. The majority of structural deficient bridges result from increased traffic, the exponential increase in truck loads, environmental attacks (i.e. scour, freeze and thaw cycles, etc.), and the use of deicing chemicals in northern states. The Federal Highway Administration (FHWA) and State Departments of Transportation (DOTs) have recently established research programs to investigate the possibility of using newer and higher grade construction materials to increase bridges life-span, reduce the bridge life cycle cost, and minimize the need to major maintenance, repair, and replacement activities of the major structural

Amin Akhnoukh is Associate Professor at the Construction Management & Civil and Construction Engineering Department at the University of Arkansas at Little Rock, PH (501) 683 7758, (e-mail: akahnoukh@ualr.edu).

components within the bridge. New construction materials include ultra-high performance concrete, fiber-reinforced polymers, and large-diameter prestress strands.

II. LITERATURE REVIEW

Large-diameter prestress strands have been used for decades in cable-stayed bridges and mining applications in the United States and post-tensioned tendons in Europe and Japan. Seven-wire low-relaxation prestress strands of 0.7 inch diameter were introduced for the first time in pretensioned applications in North America in the construction of the Pacific Street and Interstate 680 highway bridge in Omaha, Nebraska, as shown in Fig. 1.



Fig. 1 Pacific Street and Interstate 680 Bridge, Omaha, Nebraska

The bridge girders were fabricated using 0.7 inch strands placed at centerline spacing in excess of 2 inch [1]. Larger strand spacing was favored by the Nebraska Department of Roads (NDOR) engineers, structural designer, and the fabricator to avoid possible structural and fabrication problems due to the substantial increase in prestressing force associated with the large strand cross section area. The main impediments to using larger strands are: 1) lack of prestressing bed capacities, 2) lack of structural knowledge regarding the transfer and development lengths of larger strands, 3) absence of statistical data regarding mechanical properties of large-diameter strands including yield and ultimate stress, 4) the safety hazard associated with strand harping due to the absence of sufficient pull-down devices, and 5) the possibility of developing wider end zone cracks upon strand release. In a recent study, steel reinforcement was recommended to avoid splitting or excessive cracking at the interfacing surface between bottom flange and web when 0.7 inch strands are used in girder fabrication [3]

This paper presents a study about using 0.7 inch prestressing strands in bridge girders fabrication. The study includes two phases. An analytical phase to calculate the possible increase in flexural capacities of I-girders when 0.7 inch strands are used, and the effect of girder and deck compressive strengths on composite girder-deck capacity, and a case study to compare bridge panel design constructed using 0.7 inch and 0.6 inch diameter strands.

III. STRUCTURAL ADVANTAGES OF 0.7 INCH STRANDS

Applied by prestressing strands is linearly proportional to the cross section area of the strands. When 0.7 inch strands are used, total prestress forces are substantially increased, which increases the flexure capacity of the fabricated girders. The increase in prestress forces of 0.7 inch strands as compared to 0.6 and 0.5 inch is shown in Table I.

TABLE I
INCREASE IN PRESTRESS FORCES WHEN 0.7 INCH STRANDS ARE APPLIED AS COMPARED TO 0.6 AND 0.7 INCH STRANDS (AT VARIABLE CENTERLINE SPACING)

Vertical Spacing (in.)	Horizontal Spacing (in.)			
	2	2.1	2.2	2.25
2	35.5%	29.0%	23.2%	20.4%
2.1	29.0%	22.9%	17.3%	14.7%
2.2	23.2%	17.3%	12.0%	9.5%
2.25	20.4%	14.7%	9.5%	7.0%

The increase in prestress force results in additional girder capacity. The flexure capacity of I-girders was studied when similar numbers of strands with different diameters were used in fabrication. AASHTO LRFD strength I equation [2] was used to calculate the flexure capacity of standard I-girders when 60 strands of 0.5, 0.6, and 0.7 inch diameters were used at a horizontal and vertical centerline spacing of 2.0 inch, as shown in Fig. 2. Due to the bottom flange dimensions, a maximum of 60 strands were to be used in girder design and fabrication. It was noted during the flexure capacity calculations that the compression block was always located within the girder (girder $f_c = 4000$ psi) when 0.5 and 0.6 inch strands were used. However, the use of 0.7 inch strands and the increase of pretension force resulted in a larger compression block. Hence, the concrete strength f_c of the fabricated girder had a proportional impact on the final composite section capacity, as shown in Fig. 3.

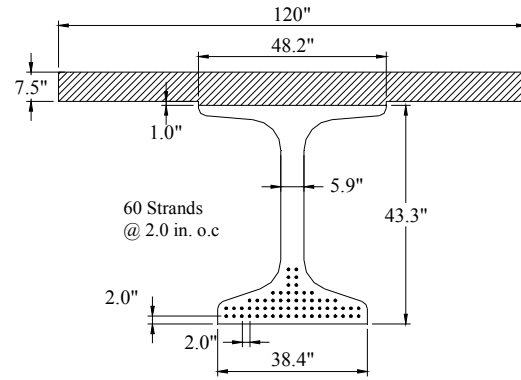

Fig. 2 I-girder with 60 strands at 2.0 inch spacing

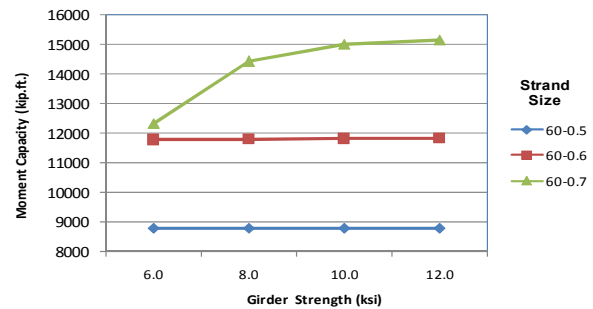

Fig. 3 Composite section capacity vs. girder concrete strength for different strand sizes

Similarly, the structural analysis and design of composite deck-girder section proved that the minimum recommended deck strength is 5000 psi. A deck strength of 4000 psi results in a significant reduction in composite section capacity due to the large portion of stress block existing within the girder top flange, as shown in Fig. 4. To-date, concrete with compressive strength of 4000 psi is widely used in bridge construction due to its sufficient performance with commonly used strands with smaller diameter.

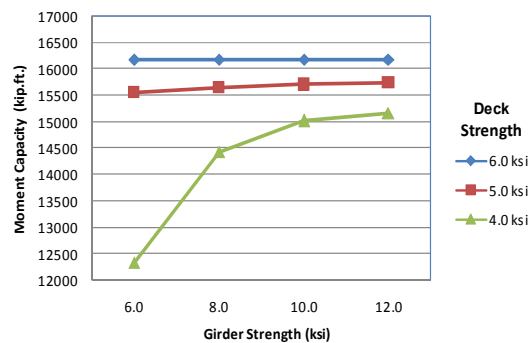

Fig. 4 Effect of deck strength on composite section capacity

IV. CASE STUDY

For research purpose, a 46 ft. 8 inch wide two-span bridge constructed with 15 ksi concrete and 0.7 inch strands I-girders was compared to a similar bridge designed using 8 ksi concrete and 0.6 inch strands. The designed bridge(s) included the following parameters:

- Girders are continuous for live load.
- Standard I-girders are used (depth = 35.4 inch) fabricated with concrete of 15 ksi final strength, and containing 60-0.7 in. strands at bottom flange.
- 4 girders are at 12 ft. spacing were used for 0.7 in. strands girders.
- 7.5 in. deck and a 1 in. thick haunch were cast in place using 5 ksi concrete.

The afore-mentioned bridge specifications were successfully used to design a 105 ft. span bridge. For comparison sake, similar bridge was designed using 8 ksi concrete and 0.6 in. strands. The design required the use of 6 girders spaced at 8 ft. spacing. Detailed designs of both girder types are shown in Akhnoukh 2008 [4]. Material quantities and production prices of the two girder types are shown in Table II. The pricing of bridges included \$850 per cubic yard for 8 ksi concrete girders, \$950 per cubic yard for the 15 ksi girders, \$450 per cubic yard for cast-in-place haunch and slab, \$0.85 per pound for prestressing strands, and \$0.75 per pound for reinforcing steel.

TABLE II
0.7 INCH STRANDS GIRDER COST ANALYSIS VS. REGULAR CONCRETE GIRDERS

	Girder Concrete (yd ³)	Slab Concrete (yd ³)	Haunch Concrete (yd ³)	Strands weight (lbs)	Slab steel (lbs)
0.7 in. + 15 ksi Girder	142	245	10.6	51,000	68,000
Cost (USD)	135,000	110,000	5,000	43,350	51,000
Total Cost (USD)			344,350		
0.6 in. + 8 ksi Girders	213	245	15.9	56,000	68,000
Cost (USD)	181,000	110,000	7,000	47,600	51,000
Total Cost (USD)			396,600		

By comparing the production cost of both design alternatives for the bridge superstructure, shown in Fig. 5, a direct saving of 14% is achieved when bridge girders are fabricated using 15 ksi and 0.7 in. prestressing strands compared to the current practice, where 8 ksi and 0.6 in. prestressing strands are used. In addition to the direct saving in material cost, the use of fewer girder lines reduces girders transportation cost, expedite the construction process, and reduce the total number of strands used in bridge construction, which improves the overall safety of the project.

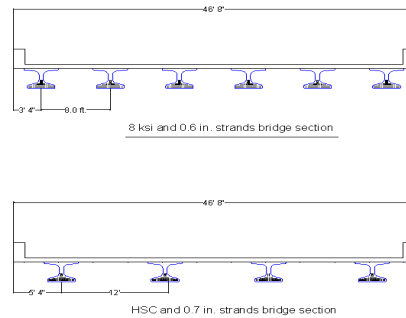

Fig. 5 Alternative Bridge Designs

V. CONCLUSIONS

The use of large-diameter prestress strands results in a significant increase in I-girders capacities. The advantages of using large strand diameters are maximized when high strength concrete is used in girder fabrication and concrete mixes of 5000 psi (or more) are used to pour bridge decks. Structural advantages are associated with reduction in material quantities/cost, expedited construction process, and possible increase in project safety. Future research is required to investigate the impediments to using 0.7 inch strands including prestressing bed capacities, lack of expertise or design specifications.

REFERENCES

- [1] Reiser, N.P., "Innovative Reinforced/Prestressed Concrete Bridge Superstructure Systems," A Thesis, University of Nebraska-Lincoln, Nebraska, 2007
- [2] AASHTO, LRFD Bridge Design Specifications for Highway Bridges, Third Edition, American Association of State Highway and Transportation Officials, Washington, DC, 2006
- [3] Vedivelu, J., and Ma, Z., "Potential Impact of 0.7 inch Strands on Precast/Prestressed Concrete Bridge I-Girders: Spacing of Large Diameter Strands," Proceedings of the Concrete Bridge Conference, Saint Louis, Missouri, 2008
- [4] Akhnoukh, A.K., "Development of High Performance Precast/Prestressed Bridge Girders," A Dissertation, University of Nebraska-Lincoln, Nebraska, 2008