

Evaluation of Multilevel Modulation Formats for 100Gbps Transmission with Direct Detection

Majed Omar Al-Dwairi

Abstract—This paper evaluate the multilevel modulation for different techniques such as amplitude shift keying (M-ASK), M-ASK, differential phase shift keying (M-ASK-Bipolar), Quaternary Amplitude Shift Keying (QASK) and Quaternary Polarization-ASK (QPol-ASK) at a total bit rate of 107Gbps. The aim is to find a cost-effective very high speed transport solution. Numerical investigation was performed using Monte Carlo simulations. The obtained results indicate that some modulation formats can be operated at 100Gbps in optical communication systems with low implementation effort and high spectral efficiency.

Keywords—Optical communication, multilevel amplitude shift keying (M-ASK), Differential phase shift keying (DPSK), Quaternary Amplitude Shift Keying (QASK), Quaternary Polarization-ASK (QPol-ASK).

I. INTRODUCTION

THE goal of network operators and manufacturers is to reduce the cost by modifying the already installed systems. With increasing demand for high speed communication systems and the use of high-speed services of modern communication systems, the cost of installing new equipment compatible with the required ultra-high data rates is increasing due to the use of complicated transmitter and receiver configurations. One of the proposed solutions is using the well-known and simplest modulation format which is on-off keying (OOK) and extended it to multilevel amplitude-shift-keying (M-ASK), which makes it more suitable for high speed and at the same time cost-effective. The M-ASK format has advantage of low complexity as direct detection and direct modulation can be used. In [1] the performance of the 10 Gbit/s 4-ary amplitude shift keying (4ASK) systems in dispersive environments at 1550nm has been studied. Both non-return-to-zero (NRZ) and return-to-zero (RZ) format, multilevel modulation formats have been proposed. Multilevel modulation format with 6 symbols, which involves encoding an average of 2.5 bits per symbol, is proposed in [2]. This approach provides high capacity and cost-effective transmission. In [3] low-cost multilevel modulation format for 100Gbps was investigated. Optimization of Cost Efficient Multilevel-ASK Modulation Formats under the Constraint of Chromatic Dispersion was investigated results optimized the amplitude levels of unipolar and bipolar multilevel ASK signals for the use in cost efficient optical metro networks to

achieve maximum chromatic dispersion tolerance [4]. The possibility of generation quaternary multi-level modulation formats with polarization division multiplexing (4-ary intensity modulation (IM)) was investigated [5]. Other works investigated the combination of ASK and PSK with different models [6]-[8], resulting in greater noise tolerance and chromatic dispersion tolerance. [9] Proposed optimum amplitude ratio and investigated chromatic dispersion tolerances of optical quaternary ASK-DPSK and 8-ary ASK-DQPSK. Three bits per symbol has already been demonstrated using a combination of DQPSK and amplitude shift keying [10] or using pure phase modulation (8-DPSK) [11].

In the next section of this paper, the modulation scheme multilevel amplitude shift keying (M-ASK) is investigated with the total transmission data rate of 107Gbps. Then M-ASK combined with DPSK were investigated. We call these formats M-ASK-Bipolar as the symbols have opposite sign (i.e. π phase shift) and the value M clearly indicates the number of symbols used. Then QASK and QPolASK are presented [4]. The performance of M-ASK, M-ASK-Bipolar, QASK and QPolASK is investigated and discussed in Sections III and IV. The main focus of this paper is to investigate the noise performance as this is a critical issue in high-speed multilevel signaling.

II. TRANSMITTER AND RECEIVER SET-UP

A. Multilevel Amplitude Shift Keying Transmitter

The M-ASK transmitter is shown in Fig. 1 (a), here for the example $M = 4$. The system consists of a 4-level amplitude-shift-keying encoder (2/4), a pulse shaper and a direct modulated laser (DML) for low-cost operation. The implementation of 4ASK was done with two independent data streams with data rate of 53.5Gbps each, resulting in four different amplitude levels at the output of the 4ASK transmitter sending 2bits per symbol at a Baud rate of 53.5GBaud, the corresponding spectral width, and resulting in a total transmission data rate of 107Gbps. The implementation of 8ASK was done with three independent data streams with a data rate of 35.67Gbps each. After passing the (3/8) encoder this results in 8 different amplitude levels with 3 bits per symbol with spectral width according to the low 35.67GBaud rate. Extension to higher level constellations is straight forward. The Gray code was chosen for all encoders.

The receiving side (Fig. 1 (b)) consists of an optical filter, photo diode for direct detection, sampling, decoder, and decision device to estimate the bit sequence. An optical amplifier (EDFA) is used for noise loading. The optical

Majed Omar Al-Dwairi is Associate professor since 2011, working at al-Qalqa Applied University/Faculty of Engineering Technology-Electrical department since 2002, Visiting professor in Jerash University, Dean of Engineering Faculty 2012 (e-mail majeddw@gmail.com).

receiver filter is 2nd order 107GHz Gaussian band-pass filter. The electrical receiver filter is 3rd order 74.9GHz Bessel low-pass filter. The constellation diagrams are shown in Fig. 1 (c). The receiver for M-ASK differs from 4ASK by the decoder which converts the M levels to $\text{ld}(M)$ data streams.

B. Multilevel Amplitude Shift Keying- Bipolar Transmitter

The M-ASK-Bipolar transmitter shown in Fig. 2 for the example of $M = 4$ consists of the DML followed by a Mach-Zehnder modulator (MZM), which plays the role of a phase-modulator by adjusting the bias voltage $V_{bias} = U_{\pi}$ (U_{π} the switching voltage) and using equal drive voltages $U_1 = U_2$. The electrical drive signal $\beta(t)$ generated from the differentially encoded bit sequence β_k modulates the phase of the optical signal, such that two phase angles 0 and π exist (see Fig. 2 (c)).

smaller than the data rate of 107Gbps. In general, at the receiver, M/2 symbols are detected in the ASK branch whereas the sign is detected by the DPSK branch. The constellation diagram and transitions between the signal points for 4ASK-Bipolar, 8ASK-Bipolar and 16ASK-Bipolar are shown in Fig. 3.

C. Quaternary Amplitude Shift Keying Transmitter and Receiver

The QASK Transmitter and receiver shown in Fig. 4 consist of two unequal amplitude data streams with total data rate 107Gbps (53.5Gbps each) one of data generators multiplies by factor $k = 1/2$ to creates unequal amplitude and the modulators are 90° shifted to creates two different binary NRZ with the same carrier frequency for both modulators and consists of the DML followed by two Mach-Zehnder modulator (MZM) [4].

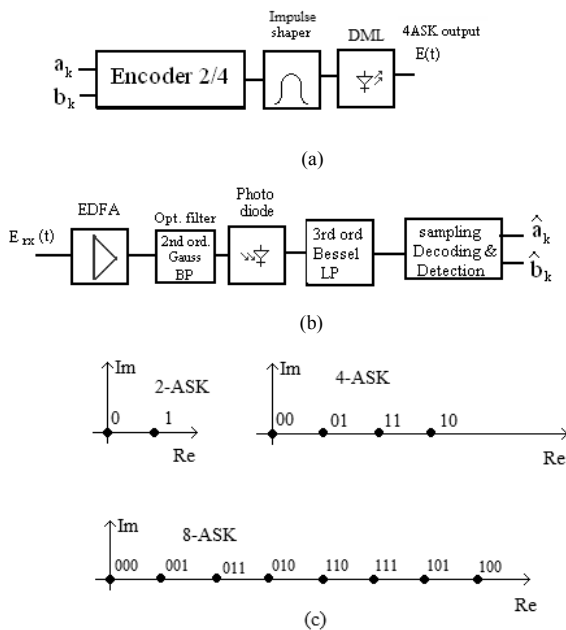

Fig. 1 (a) 4ASK transmitter, (b) 4ASK receiver, and (c) 2-ASK, 4-ASK, and 8ASK constellation diagram, respectively

At the receiver side, the phase-encoded bit sequence is detected by a conventional DPSK receiver made up from a delay interferometer and balanced photo detectors. The electrical drive signal $\alpha(t)$, generated from the bit sequence α_k , modulates the amplitude of the optical signal from the DML, resulting in two different amplitudes a and b . The implementation of 8ASK-Bipolar was done with two independent data streams with a data rate of 35.67Gbps each, for the amplitude modulation (4 levels). The third data sequence from β_k controls the sign (i. e. phase 0 or π) of the resulting symbols, thus ending up with an 8-level bipolar constellation (see Fig. 2 (c)). The implementation of 16ASK-Bipolar requires 3 data streams for the amplitude modulation, giving 8 different amplitude levels and a fourth data stream from β_k for the phase modulator. Thus we encode 4 bits per symbol and the Baud rate of 26.75GBaud is by the factor of 4

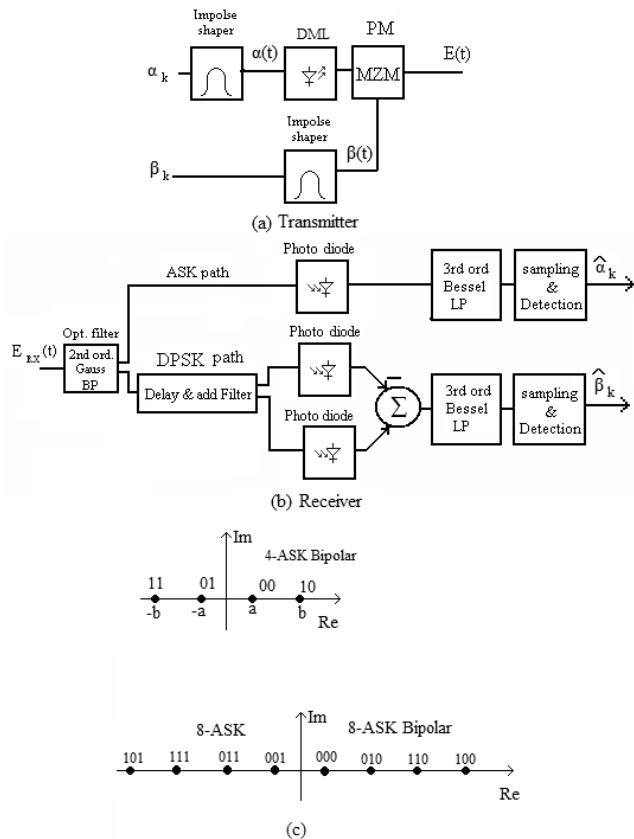

Fig. 2 (a) 4ASK-Bipolar transmitter, (b) 4-ASK-Bipolar receiver, (c) 4-ASK Bipolar, and 8ASK Bipolar constellation

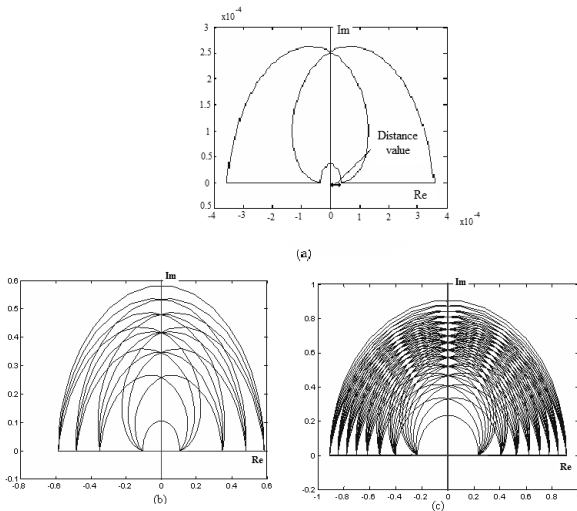

Fig. 3 The constellation diagram and transitions between the signal points: (a) 4ASK-Bipolar, (b) 8ASK-Bipolar, (c) 16ASK-Bipolar

D. Quaternary Polarization Amplitude Shift Keying Transmitter

The quaternary Polarization-ASK (QPol ASK) transmitter shown in Fig. 5 is based on the transmission of two orthogonally polarized modes [5], [12].

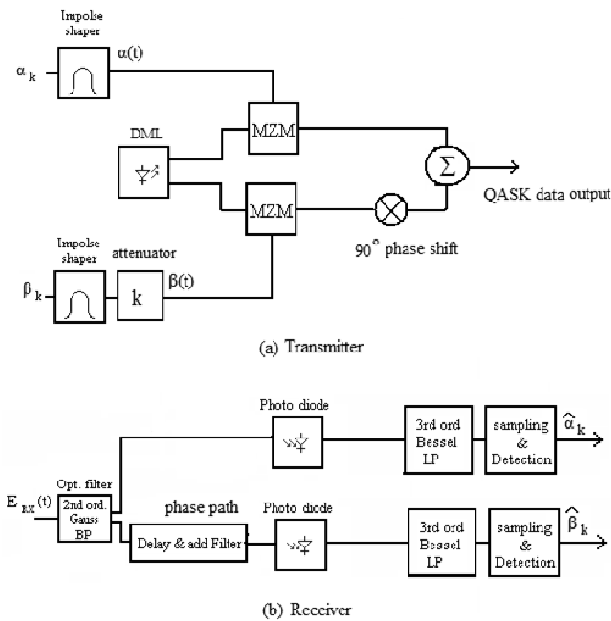

Fig. 4 (a) QASK transmitter and (b) QASK receiver

In this implementation two independent NRZ ASK data modulator outputs with unequal amplitudes are transmitted on these two orthogonally polarized modes to increase the transmission capacity and the DML followed by two Mach-Zehnder modulator (MZM) with polarization beam combiner [4]. The electric field component (E-vector) of an electromagnetic field can be approximated by solutions to the

wave equations. This results in a fundamental single mode which is a linear polarized transverse wave [5]. The E-vector can therefore be resolved into orthogonal components namely E_{0x} and E_{0y} . These orthogonal modes can then used to carry data from two independent data channels hence making polarization division multiplexing feasible. The orthogonal modes resolution is given by (1) which is called Jones-Vector, J .

$$E = \begin{bmatrix} E_{0x} e^{j\phi_x} \\ E_{0y} e^{j\phi_y} \end{bmatrix} \quad (1)$$

In order to find the relationship between the input and output electric field, it will be assumed that there is a linear relation between the incident and emerging light beam of polarizing elements [13]. A polarizing element is a device or interface that differentially transmits orthogonal polarization states [14]. The input electric field is therefore related to the output by the relation in (2) [5].

$$\begin{bmatrix} E'_{ox} \\ E'_{oy} \end{bmatrix} = \begin{bmatrix} j_{xx} & j_{xy} \\ j_{yx} & j_{yy} \end{bmatrix} \begin{bmatrix} E_{0x} \\ E_{0y} \end{bmatrix} \quad (2)$$

(where j = jones matrix)

Where E_{0x} and E_{0y} are the orthogonal polarizations of the input electric fields E'_{ox} and E'_{oy} are the output orthogonal electric field components of x and y directions respectively. The 2×2 matrix J is called the Jones matrix and the elements of the matrix are used for transforming the input vector to an output vector by the polarizing elements.

The set-up to QPolASK transmitter is shown in Fig. 5. Two data channels with unequal amplitude are multiplied unto orthogonal polarizations before being sent through the fiber, resulting 4-level signal thereby achieving a multi-level modulation with polarization division multiplexing.

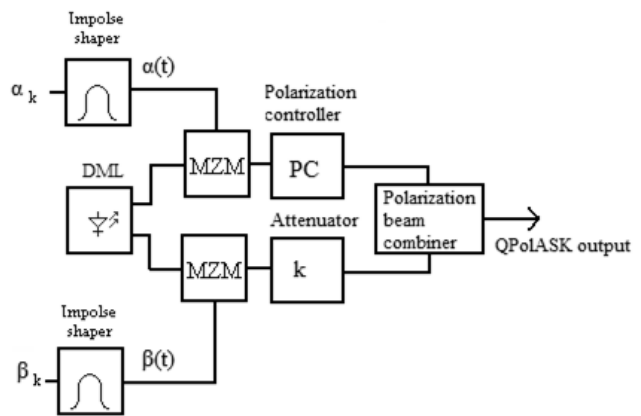

Fig. 5 QASK transmitter

III. RESULTS OF SIMULATION

A. M-ASK

The simulations were carried out for NRZ ASK modulation format to ascertain its performance against different transmission levels. The MOVE_IT simulation tool, which is available at the Chair for Communication of Christian-Albrecht's-University in Kiel-Germany, was used for this purpose. The simulation was done with a back-to-back (B2B) configuration set-up. The eye-diagrams for 4ASK and for 8ASK at low BER are shown in Figs. 6 and 7.

The simulation results of OSNR vs. BER for 2ASK, 4ASK and 8ASK are shown in Fig. 16 were the plot for 4ASK, and 8ASK are the average value as we are dealing with two and three data sources respectively.

B. M-ASK-Bipolar

In 4ASK-Bipolar it is important to find the best distance value (see Fig. 3 (a)) in terms of the ration b/a to make the BER for ASK part and DPSK part equal. For very small distance a the BER for ASK part is better than the DPSK part. By increasing this distance, DPSK part becomes better, so it is important to find the optimum distance value for best BER for both ASK part and DPSK part as we finally deal with average BER value from both arms. In [6], the optimal amplitude ratio of the 4-ASK-Bipolar was investigated at OSNR 22dB for different amplitude ratio we received the optimum ratio 2.769 shown in Fig. 8 which shows BER vs. b/a . The simulation results for this optimum amplitude ratio at 107Gbps are shown in Fig. 9 [3].

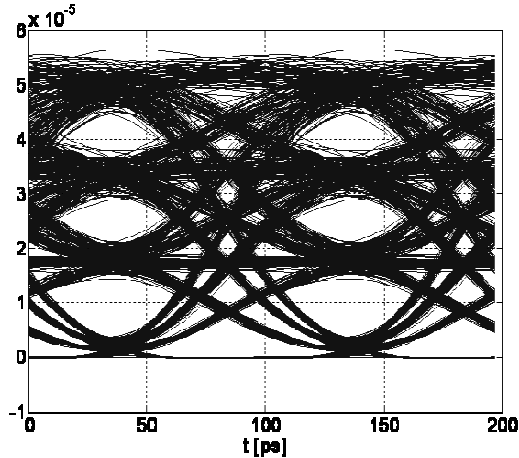

Fig. 6 4ASK for 107Gbps at High OSNR, low BER

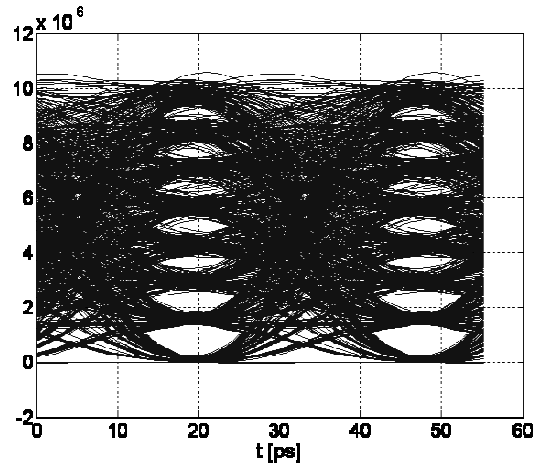

Fig. 7 8ASK for 107 Gbps at high OSNR, low BER

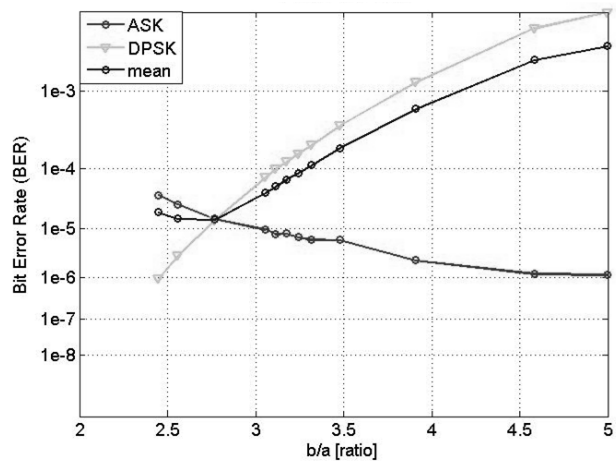

Fig. 8 Bit error Probability Vs. amplitude ratio b/a , of 4ASK-Bipolar at OSNR 22dB

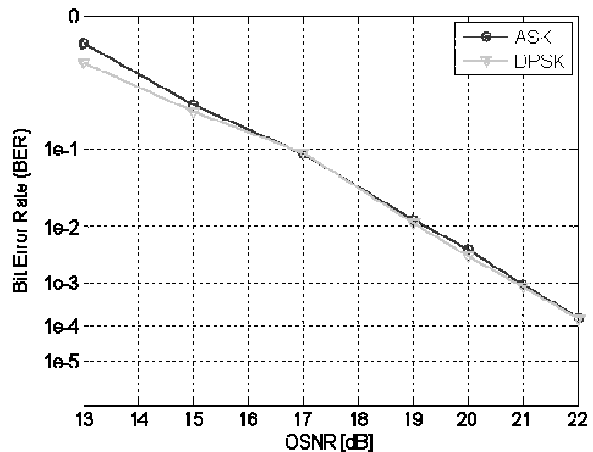

Fig. 9 4ASK-Bipolar

The eye diagrams for 4ASK-Bipolar and 8ASK-Bipolar are shown in Fig. 10.

The BER simulation results for 4ASK-Bipolar, 8ASK-Bipolar and 16ASK-Bipolar are also shown in Fig. 16, were the plot for 4ASK-Bipolar, 8ASK-Bipolar, and 16ASK-Bipolar are the average value as we are dealing with two, three and four data sources respectively.

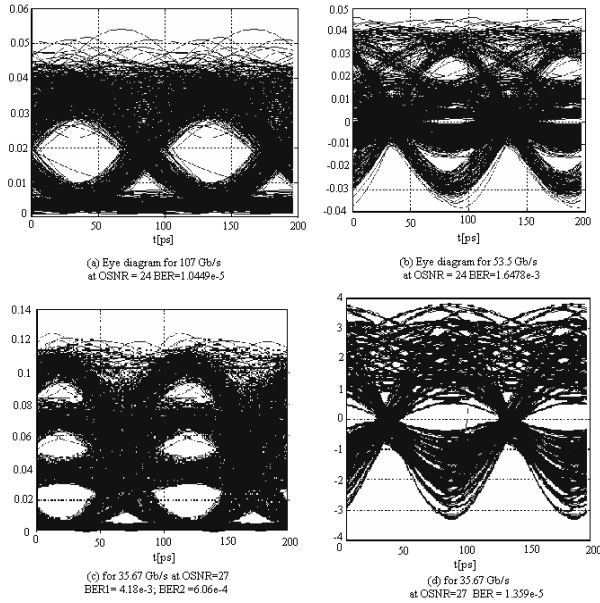

Fig. 10 MASK-Bipolar (a) 2ASK part 53.5 Gbps, (b) DPSK part 53.5Gbps, (c) 4ASK part 35.67Gbps, and (d) DPSK part 35.67Gbps

C. QASK

The total transmission rate is 107Gbps was investigated in [5] as the modulation rate is doubled were the total bandwidth is the same as NRZ ASK while the speed equipment requirement through the same transmission is achieved as ASK. The coding for QASK at the transmitter is shown in Table I. here we are dealing with 4-levels presented to the photodiode due to multiplying the second data input by a factor of $k = 1/2$ and shifted by 90° out of phase results in 4 different values. The constellation of QASK resulting two unequal OOK data ('1','0') in quadrature phases and corresponding eye diagram are shown in Fig. 11. Fig. 12 shows back-to-back OSNR for QASK the two independent and unequal data streams denoted d_0 and d_1 and the average of the two data streams [5].

TABLE I
QASK TRANSMITTER CODING

Input1= D_0	Input2= D_1	Quadrature Combined output	Intensity Values	Intensity Level
0	0	$0 + j0$	0	0
0	1	$0 + j^{1/2}$	$(1/2)^2$	1
1	0	$1 + j0$	1^2	2
1	1	$1 + j^{1/2}$	$1^2 + (1/2)^2$	3

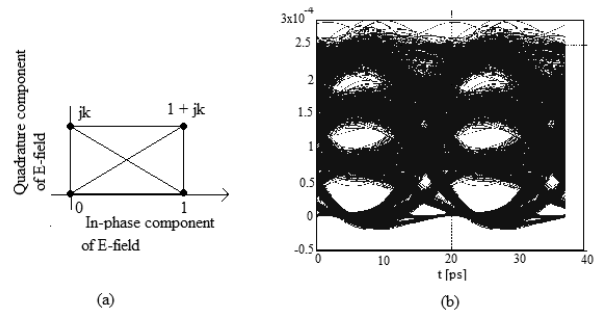

Fig. 11 (a) Constellation diagram and (b) eye diagram of QASK (2x 53.5 Gbps)

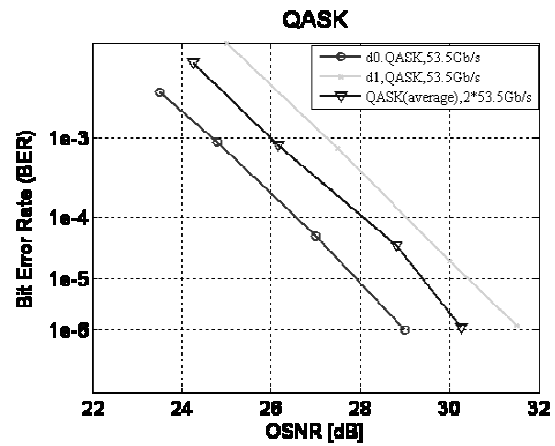

Fig. 12 Back-to back OSNR for QASK

D. QPolASK

The simulation was done using B2B configuration set-up, with two data streams are of binary NRZ ASK format each 53.5Gbps resulting total transmission rate 107Gbps [5]. Since a beam of light can exist in two orthogonal polarizations, these can be used to combine the data streams to realize a 4-level signal. The data streams correspond to '1' or '0', hence combining two unequal such data streams in orthogonal polarizations will results in 4 points constellation. The resulting and eye diagram for QPolASK shown in Fig. 13. Back-to-back OSNR for QPolASK is shown in Fig. 14.

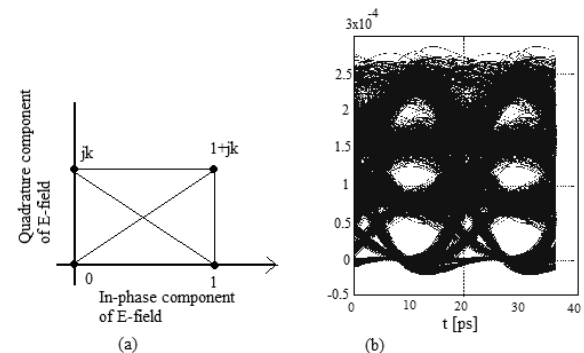

Fig. 13 (a) Constellation diagram and (b) eye diagram of QPolASK (2x 53.5 Gbps)

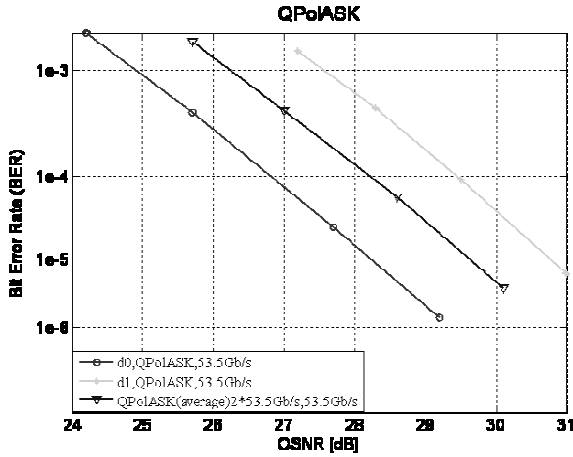

Fig. 14 Back-to-back OSNR for QPoASK

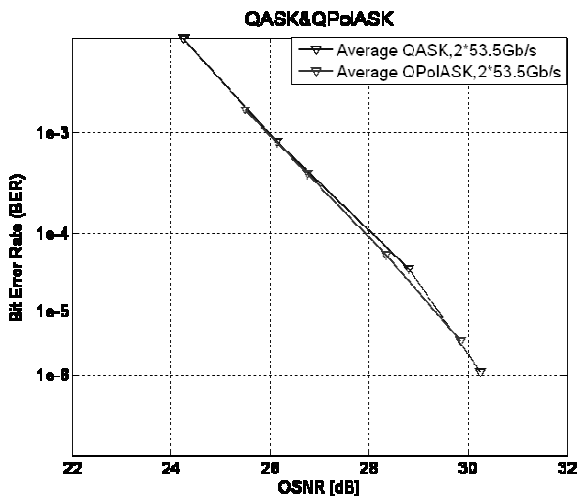

Fig. 15 Back-to-Back OSNR for Average QASK and average QPoASK

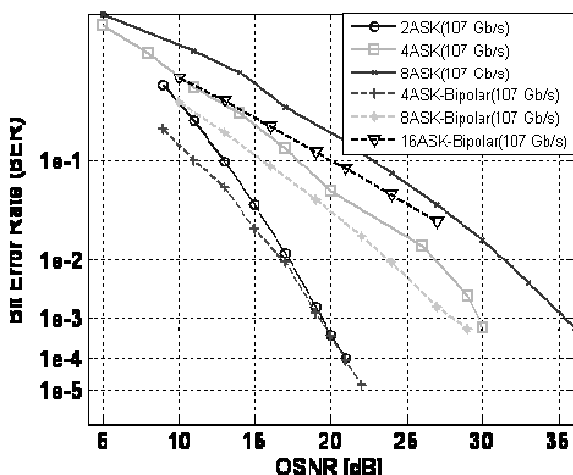

Fig. 16 Bit error probabilities vs. optical signal to noise ratio

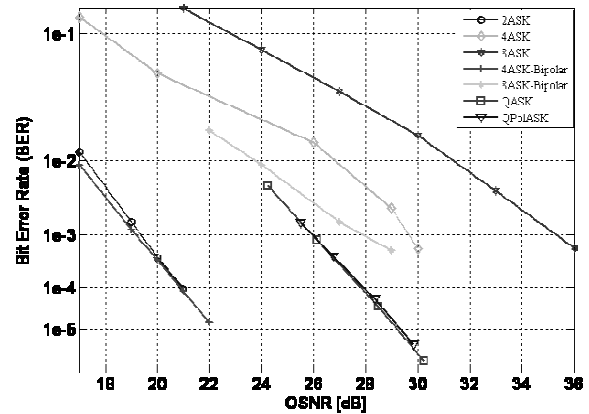

Fig. 17 Bit error probabilities vs. optical signal to noise ratio for all types

IV. DISCUSSION

From the simulation results shown in Fig. 16 the best BER received for 4ASK-Bipolar which is about the same as 2ASK followed by 8ASK-Bipolar, which indicates the perspective of using 4ASK-Bipolar modulation format for 107Gbps transmission while the worse results were received for 8ASK followed by 16ASK-Bipolar due to the noise in different levels. Comparing the received results for BER=10⁻³ shows, that 4ASK-Bipolar is better than 2ASK about 1dB, and better than 8ASK-Bipolar about 8dB, and better than 4ASK about 10dB, indicating the perspective of 4ASK-Bipolar. By comparing 107Gbps 4ASK-Bipolar with 10Gbps 4ASK-Bipolar at the same BER it was worse about 10dB which was expected as we are dealing with 10 times more speed. From the results shown we find that M-ASK-Bipolar is always better than MASK, except 16ASK-Bipolar was worse than 8ASK due to the noise from the different levels, which means that 16ASK-Bipolar need adjusting to get the same level spacing, which will be done in the next step. According to eye diagrams always the higher levels are more distorted than the lower. This distortion comes from the noise in higher levels and from using Gray code.

The simulation results for QASK and QPoASK are shown in Figs. 11-15 the performance of both types about the same, showing that these implementations had the similar performances of OSND requirements. The BER performance of d₀ is better than d₁, the upper eye level has the smallest eye opening indicate a worse performance this translate to the poor BER performance in output d₁, as the BER values are related to signal energy and noise level as shown in [13], therefore higher noise will result in worse BER performance comparing all modulation formats Fig. 17 always DPSK part gives better performance because of dealing with two phases instead of four levels or higher.

V. CONCLUSION

The simulation results shows gives a possibility of different modulation format that could be increased the transmission

capacity without increasing the modulation data rate at the same time using low cost modulation format MASK, MASK-Bipolar, QASK and QPolASK which could be an optimal low cost transmission format as the using transmitter and receiver design are simple and not expensive. Simulation results show that M-ASK, M-ASK-Bipolar, QASK and QPolASK are promising modulation formats for using in high speed transmission at 107 Gbps. where best simulating results were obtained for 4ASK-Bipolar, QASK, QPolASK and 8ASK-Bipolar respectively.



Majed Omar Al-Dwairi is Associate professor since 2011, working at al-Qalqa Applied University/ Faculty of Engineering Technology-Electrical department since 2002, Dean of Engineering Faculty Jerash University 2012. He was born in Amman Jordan 10/12/1968, his BS, Ms and PhD from Odessa National Academy of Telecommunication/Ukraine 1998. He is specialist in Multichannel communication systems. The major fields of study are fiber optics modeling and signal and image processing.

ACKNOWLEDGMENTS

Author would like to thanks Prof. Dr. Ing. Werner Rosenkranz for his help, and advices in Chair for Communication in Technical Faculty/CAU.

REFERENCES

- [1] N. Avlonitis E. M. Yeatman M. Jones "Multilevel amplitude shift keying in dispersion uncompensated optical systems", UK Optoelectronics, IEE Proceedings - Publication Date: 12 June 2006 Volume: 153 ,
- [2] Michael Eiselt "Cost-effective 100Gbps Optical Modulation Format for Metro Networks", Brian Teipen, Presentations of the 9th ITG Conference "Photonische Netze" Germany Leipzig 2008.
- [3] Majed Omar Al-Dwairi, Ziad A. AlQadi "Low-cost Multilevel Formats for 100Gbps Transmission with Direct Detection", International Review of Physics (IREPHY) vol.3 N.5, october 2009.p
- [4] Annika Dochhan, Majed Omar Al-Dwairi, and Werner Rosenkranz "Optimization of Cost Efficient Multilevel-ASK Modulation Formats under the Constraint of Chromatic Dispersion" OFC 2010, paper OMIJ7, 23.-25.03.2010, San Diego, California, USA
- [5] S. K. Andoh Okai "Investigation of multi-Level Modulation Formats with Polarisation Multiplexing in Optical Communication Systems" Master Thesis, Christian-Alberchts University, Germany 2009.
- [6] M. Ohm and J. Speidel, "Quaternary optical ASK-DPSK and receivers with direct detection (ASK-DPSK/DD)," *IEEE Photon. Technol. Lett.* 15, pp. 159–161, Jan. 2003.
- [7] X. Liu, X. Wei, Y.-H. Kao, J. Leuthold, C. Doerr, and L. Mollenauer, "Quaternary differential-phase amplitude-shift-keying for DWDM transmission," in *Proc. ECOC'03*, paper Th 2.6.5, 2003.
- [8] S. Hayase, N. Kikuchi, K. Sekine, and S. Sasaki, "Proposal of 8-state per symbol (binary ASK and QPSK) 30-Gbit/optical modulation / demodulation scheme," in *Proc. ECOC'03*, paper Th 2.6.4, 2003.
- [9] Ohm, M; Speidel, J: "Optimal amplitude and chromatic dispersion tolerances of optical quaternary ASK-DPSK and 8-ary ASK-DQPSK", Asia-Pacific Optical Communication (APOC). Beijing, China, November 2004, paper 5625-38.
- [10] T. Tokle et al, "Penalty-free Transmission of Multilevel 240 Gbit/s RZ-DQPSK-ASK using only 40 Gbit/s Equipment", in Proc. ECOC 2005, post deadline paper Th4.1.6, Vol. 6, pp. 11-12.
- [11] M. Serbay et al, "Experimental Investigation of RZ-8DPSK at 3x10.7Gbps", in Proc. LEOS 2005, paper We3, pp. 483-484.
- [12] S. S. Walkin, "Multilevel Signaling for Increasing the Capacity of High-Speed Optical Communication Systems", Ph.D. thesis, University of Alberta, Canada, 1997.
- [13] E. Collett, *Polarized light: Fundamentals and Applications*, Marcel Dekker, 1993, ISBN 0-8247-8729-3.
- [14] D. B. Chenault, "Polarization: Nomenclature and Background", in *Conference 6682 as part of SPIE's Optics + photonics*, San Diego, California, USA, August 2007.