

General Purpose Pulse Width Modulation Based Sliding Mode Controller for Buck DC-DC

M.Bensaada , A.Boudghene Stambouli , M.Bekhti, A. Bellar, L. Boukhris

Abstract—This paper is a simple and systematic approaches to the design and analysis a pulse width modulation (PWM) based sliding mode controller for buck DC-DC Converters. Various aspects of the design, including the practical problems and the proposed solutions, are detailed. However, these control strategies can't compensate for large load current and input voltage variations. In this paper, a new control strategy by compromising both schemes advantages and avoiding their drawbacks is proposed, analyzed and simulated.

Keywords—buck; DC/DC converters; sliding mode control, pulse width modulation

I. INTRODUCTION

THE buck type DC-DC converters are used in applications where the required output voltage needed to be smaller than the source voltage. The control of this type DC-DC converters is more difficult than the buck type where the output voltage is smaller than the source voltage. The difficulties in the control of buck converters are due to the non-minimum phase structure i.e. since, the control input appears both in voltage and current equations, from the control point of view the control of buck type converters are more difficult than buck type [1].

A control technique suitable for DC-DC converters must cope with their intrinsic nonlinearity and wide input voltage and load variations, ensuring stability in any operating condition while providing fast transient response. Since switching converters constitute a case of variable structure systems, the sliding mode (SM) control technique can be a possible option to control this kind of circuits. The use of sliding mode control enable to improved and even overcome the deficiency of the control method based on small signal models. In particular, sliding mode control improves the dynamic behaviour of the system, endowing it with characteristics such as robustness against changes in the load, uncertain system parameters and simple implementation [2].

M.Bensaada, M.Bekhti, A. Bellar, and L. Boukhris are with the centre of space techniques BP 13, 31200, Arzew, Algeria (phone: +213-41-47-22-17; fax: +213-41-47-36-65; e-mail: m.bensaada@yahoo.fr, m_bekhti@yahoo.fr).

A.Boudghene Stambouli is with University of Sciences & Technology of Oran Mohamed Boudiaf, Algeria (phone: + 213-41-56-03-29; fax: +213-48-57-58-35; e-mail: aboudghenes@yahoo.com).

Study of a fixed-frequency SM controllers has focused on the practical constrains. In view of this, we propose in this paper a fixed frequency, which is based on an indirect sliding mode control technique and is implemented in pulse width modulation (PWM), this controller can offer good large signal control performances with fast dynamical response.

In order to assure that the controlled system operates properly the existence condition and stability must be verified. These are the summarized controller design steps; but also the system modeling could be considered as a design step.

II. SLIDING MODE CONTROL OF BUCK DC-DC CONVERTER

The sliding mode control is based on the variable structure theory [3]-[4], and introduces to the complete system a good dynamic response and also robustness to large load and input voltage variations. The sliding mode control operates in a simplified way as follows: a sliding surface is defined with the equilibrium point, and the system is forced to be held into the sliding surface (existence condition), and then the system must reach the equilibrium point (stability).

A. System Modeling

To illustrate the underlying principal, the state space description of the buck converter under sliding mode voltage control, where the control parameters are the output voltage, output voltage error dynamic, inductor current and reference voltage (in phase canonical form) [6], is first discussed.

Figure (1) shows the schematic diagram of a sliding mode control buck converter. This section covers the theoretical aspects of the sliding mode control converter. A practical method to determine the sliding coefficients is also introduced.

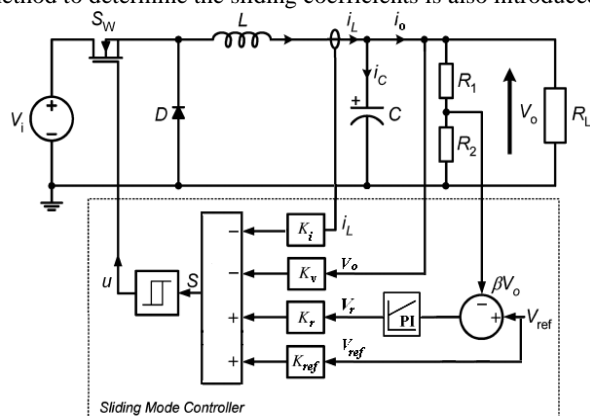

Fig. 1 Proposed sliding mode control circuit for buck DC-DC converter

$$\begin{cases} \dot{V}_r = -\beta V_o + V_{ref} \\ \dot{V}_o = -\frac{1}{R_L C} V_o + \frac{1}{C} I_L \\ \dot{I}_L = -\frac{1}{L} V_o + \frac{1}{L} V_i U \end{cases} \quad (1)$$

$$\begin{cases} \dot{S}_{S \rightarrow 0^+} = J^T A x + J^T B U_{S \rightarrow 0^+} + J^T D < 0 \\ \dot{S}_{S \rightarrow 0^-} = J^T A x + J^T B U_{S \rightarrow 0^-} + J^T D > 0 \end{cases} \quad (6)$$

Where C , L , and R_L are the capacitance, inductance, and load resistance respectively; V_{ref} , V_i , βV_o and I_L are the reference, input voltage, sensed output voltage and inductance current respectively; and $U = 1$ or 0 is the switching state of power switch SW. Then, the state space model of the system (1) can be derived as:

$$\dot{x} = A x + B U + D \quad (2)$$

Where

$$A = \begin{bmatrix} 0 & -\beta & 0 \\ 0 & -\frac{1}{R_L C} & \frac{1}{C} \\ 0 & -\frac{1}{L} & 0 \end{bmatrix}, \quad B = \begin{bmatrix} 0 \\ 0 \\ \frac{V_i}{L} \end{bmatrix}, \quad D = \begin{bmatrix} V_{ref} \\ 0 \\ 0 \end{bmatrix} \text{ and } x = \begin{bmatrix} V_r \\ V_o \\ I_L \end{bmatrix}$$

B. Controller Design

The basic idea of SM control is to design a certain sliding surface in its control law that will direct the trajectory of the state variables towards a desired origin when coincided [5]. The sliding mode controller has a switching function:

$$U = \begin{cases} 1 & \text{when } S > 0 \\ 0 & \text{when } S < 0 \end{cases} \quad (3)$$

where S is the instantaneous state variables trajectory, and is near to zero, it's described as:

$$S = -k_i I_L - k_v V_o + k_r V_r + k_{ref} V_{ref} \quad (4)$$

with $J^T = [k_i \quad k_v \quad k_r \quad k_{ref}]$ and k_i, k_v, k_r and k_{ref} representing the control parameters termed as sliding coefficients.

As in all other SM control schemes, the determination of the ranges of employable sliding coefficients for the SMC converter must go through the process of analyzing the existence condition of the controller converter system using the Placement Robust Pole.

C. Derivation of Existence Conditions

To ensure that SM control is realizable in this system, an existence condition must be obeyed:

$$\lim_{S \rightarrow 0} S \cdot \dot{S} < 0 \quad (5)$$

Thus, by substitution the time derivative of (4), the condition for SM control to exist is:

An illustration is provided for the buck converter.

- Case 1: $S \rightarrow 0^+ \quad \dot{S} < 0$:

Substitution of $U_{S \rightarrow 0^+} = \bar{U} = 0$ and the matrices into (6) gives:

$$K_r(V_{ref} - \beta V_o) - k_v \left(\frac{1}{C} I_L - \frac{1}{R_L C} V_o \right) + k_i \frac{1}{L} V_o < 0 \quad (7)$$

- Case 2: $S \rightarrow 0^- \quad \dot{S} > 0$:

Substitution of $U_{S \rightarrow 0^-} = \bar{U} = 1$ and the matrices into (6) gives:

$$K_r(V_{ref} - \beta V_o) - k_v \left(\frac{1}{C} I_L - \frac{1}{R_L C} V_o \right) + k_i \left(\frac{1}{L} V_o - \frac{V_i}{L} \right) > 0 \quad (8)$$

D. Equivalent Control

The stability analysis of the controller is made with the equivalent control; the equivalent control is substituted into the system model, and is verified under that condition.

The equivalent control is the control law when the system is into the sliding surface, and it is obtained from $\dot{S} = 0$, but changing U to the equivalent control U_{eq} . To get equivalent control, assume $\dot{S} = 0$

$$U_{eq} = \frac{L}{V_i} \left[\left(\frac{1}{R_L C} \frac{k_v}{k_i} - \beta \frac{k_r}{k_i} + \frac{1}{L} \right) V_o - \frac{1}{C} \frac{k_v}{k_i} I_L + \frac{k_r}{k_i} V_{ref} \right] \quad (9)$$

Where U_{eq} is continuous, parameter k_v/k_i and k_r/k_i are to be determined which corresponds to the desired sliding mode controller dynamics that will be discussed.

A necessary and sufficient condition of local existence of sliding regimes on S is:

$$-1 < U_{eq} < 1 \quad (10)$$

E. Equation of State in Sliding Mode

The equation of state in sliding mode is obtained by replacing in the system (2) the discontinuous control U by the equivalent control [7]. The equation of state becomes:

$$\begin{bmatrix} \dot{V}_r \\ \dot{V}_o \\ \dot{I}_L \end{bmatrix} = \begin{bmatrix} 0 & -\beta & 0 \\ 0 & -\frac{1}{R_L C} & \frac{1}{C} \\ 0 & \frac{k_v}{k_i} \frac{1}{R_L C} - \beta \frac{k_r}{k_i} & -\frac{1}{C} \frac{k_v}{k_i} \end{bmatrix} \begin{bmatrix} V_r \\ V_o \\ I_L \end{bmatrix} + \begin{bmatrix} 1 \\ 0 \\ \frac{k_r}{k_i} \end{bmatrix} V_{ref} \quad (11)$$

Let us notice that a root of the characteristic equation is null because of the linear dependence of the variables of state when the system is in sliding mode $S(x, t) = 0$. The dynamics of the

system is thus influenced by the parameters of the sliding surface k_v/k_i , k_r/k_i and the time constant of the filter $R_L C$.

However, the dynamics of the system is not affected by the variations of the voltage V_i and the inductance L .

This is due to an inherent quality of the sliding modes which is the robustness [8].

III. CONSTANT FREQUENCY OPERATION

To control the switching frequency of the converter, the relationship between the hysteresis band Δ and switching frequency f_s must be known. Figure (3) the magnified view of the phase trajectory when it is operating in sliding mode.

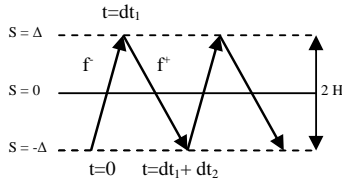

Fig. 2 Magnified view of phase trajectory in sliding mode operation

f^- and f^+ are the vectors of state variable velocity for $U=0$ and $U=1$, respectively. It was previously derived in [5] that:

$$dt_1 = \frac{2H}{\nabla S \cdot f^-} \tag{14}$$

$$dt_2 = \frac{-2H}{\nabla S \cdot f^+}$$

Where dt_1 is time taken for vector f^- to move from position (a) to (b); and dt_2 is the time taken for vector f^+ to move from (b) to (c).

$$\nabla S \cdot f = \sum \frac{\partial S}{\partial x_i} \frac{dx_i}{dt} = \frac{dS}{dt} = \dot{S} \tag{15}$$

Where

$$f = \begin{cases} f^- & \text{for } u = 0 \\ f^+ & \text{for } u = 1 \end{cases}$$

So we have

$$dt_1 = \frac{2H}{\dot{S}_{u=0} \cdot f^-} \tag{16}$$

$$dt_2 = \frac{-2H}{\dot{S}_{u=1} \cdot f^+}$$

the time period for one cycle is : $T=dt_1+dt_2$

Therefore, the time period for one cycle in which the phase trajectory moves from position (a) to (c) is equivalent to (17):

$$f_s = \frac{1}{T} = \frac{V_o(V_i - V_o)}{2\Delta V_i L} \tag{17}$$

We can see clearly that the frequency is influenced by any variation on the input voltage, a way to get a fixed frequency sliding regime is to the equivalent relationship between the Pulse Width Modulation (PWM) and the sliding regime [13]-

[14]. It is possible to synthesize the duty cycle corresponding to the Pulse Width Modulation from the theory of VSS.

This duty cycle derived from the equivalent command, applied to the converter, has the advantage of robustness compared to the variation of the input voltage V_i . The sequence (0.1) as a result, causes an oscillation of the trajectory of state around the integral manifold of the controlled system.

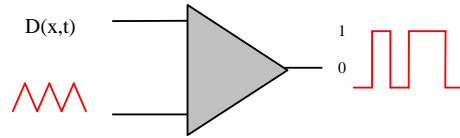

Fig. 3 Duty cycle derived from the equivalent control

IV. SIMULATION RESULTS

In this section, simulation results of the proposed sliding mode controller are provided to validate the theoretical design. The simulation program is developed from (8) for 60W Buck converters with specification shown in Table I. The control parameters adopted are $V_{ref} = 2.8$ V, $\beta = 0.1$, $k_r = 55$, $k_v = 0.045$, $k_i = 1$, and $k_{ref} = 1$. They are chosen to comply the design restrictions in (9), (11), and have been fine tuned to respond to a desired regulation and dynamic response. Figure (5) shows the full schematic diagram of the simulation model.

TABLE I
SPECIFICATIONS ADOPTED FOR THE SIMULATED INVERTER

V_i	V_o	C	L	f_s
48 V	28 V	250 μ F	125 μ F	100 z

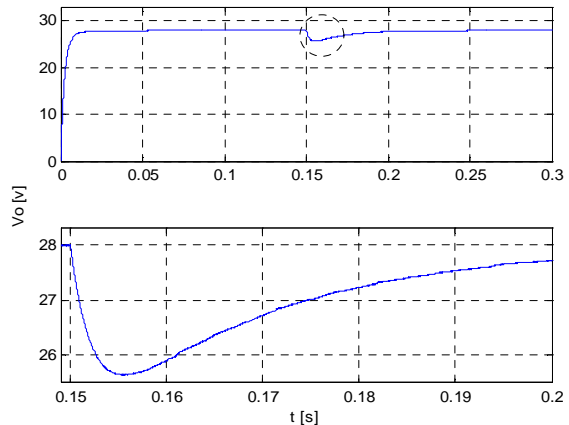

Fig. 4 Time response of output voltage V_o , under step load variation (from 15 to 20 Ω). The values of coefficients used are $k_r = 58$, $k_v = 0.043$ and $k_i = 1$, $k_{ref} = 1$

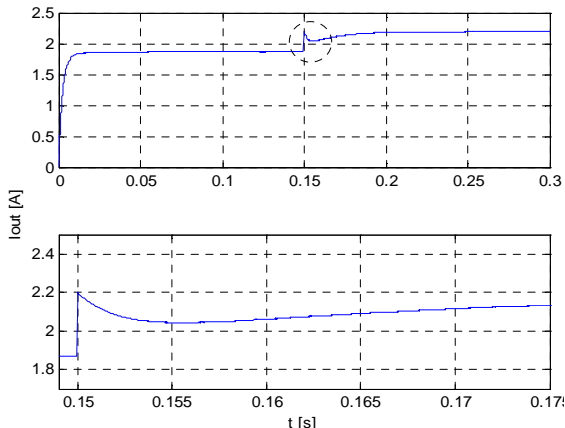

Fig. 5 Time response of output current I_{outs} under step load variation (from 15 to 20Ω). The values of coefficients used are $k_r = 55$, $k_v = 0.045$ and $k_i = 1$, $k_{ref} = 1$

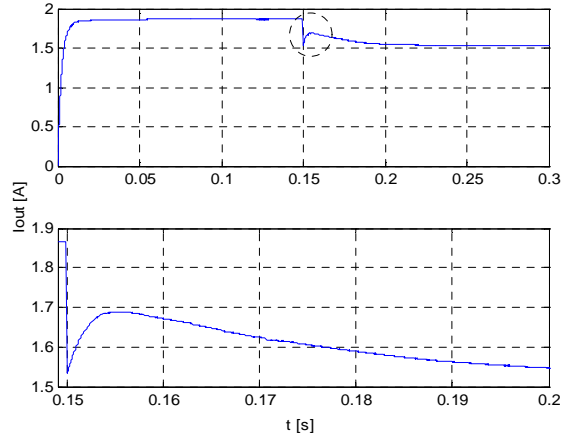

Fig. 8 Time responses of output current I_{out} and magnified output current, under step load variation (from 15 to 10Ω). The values of coefficients used are $k_r = 55$, $k_v = 0.045$ and $k_i = 1$, $k_{ref} = 1$

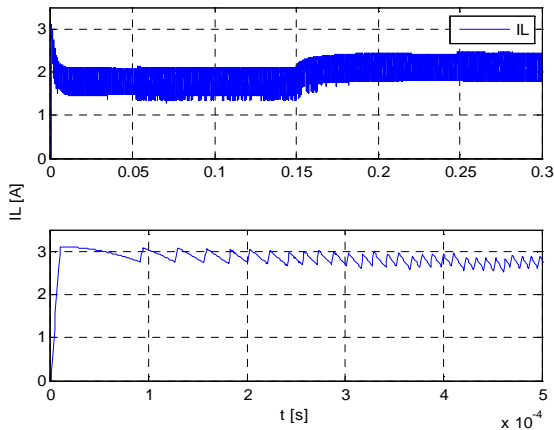

Fig. 6 Time responses of inductor current I_L , under step load variation (from 15 to 20Ω). The values of coefficients chosen are $k_r = 58$, $k_v = 0.043$ and $k_i = 1$, $k_{ref} = 1$

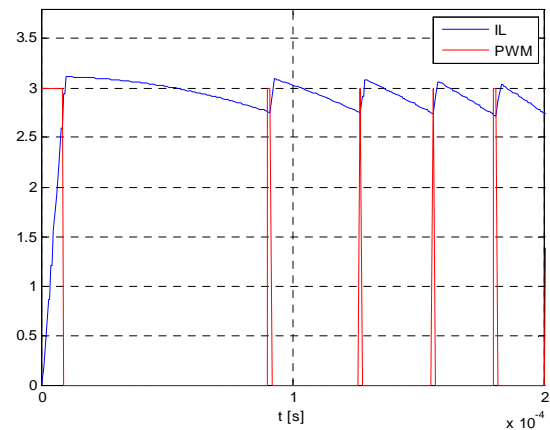

Fig. 9 Inductor current and pwm switching voltage magnified

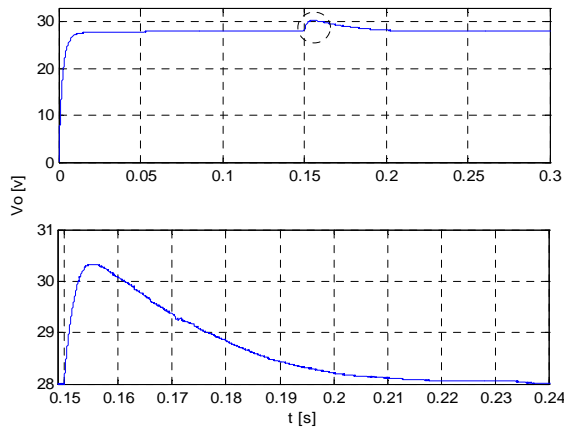

Fig. 7 Time response of output voltage V_o , under step load variation (from 15 to 10Ω). The values of coefficients used are $k_r = 58$, $k_v = 0.043$ and $k_i = 1$, $k_{ref} = 1$

V. CONCLUSION

The performance of the sliding mode Controller buck DC-DC converter are analyzed under normal and disturbance conditions. Sliding mode control is able to ensure system stability even for large input voltage and load variation, good dynamic response and simple implementation. A fast response that operates at a fixed frequency is proposed for buck converter. The various aspects of the controller, which includes the choice of sliding surface, the placement pole method for determination of controller parameters. Also additional function was implemented to provide inductor current limitation.

ACKNOWLEDGEMENTS

This research is co-supported by Space Instrumentations Division from Center of Space Techniques and laboratory of Photovoltaic Systems from Mohammed Boudiaf University of Sciences & Technology (USTO-MB).

REFERENCES

- [1] O. H. Guldemir "Sliding Mode Control of DC-DC Boost Converter", Journal of Applies Sciences 5 (3):588-592,2005, Asian Network for Scientific Information, pp588-592.

- [2] D. Seshachalam, R. K. Tripathi, and, D. Chandra, "Practical Implementation of Sliding Mode
- [3] S. C. Tan, Y. M. Lai, C. K. Tse and L. M. Salamero, "A Fast-Response Sliding-Mode Controller for Boost Type Converters With a Wide Range of Operating Conditions", IEEE Transactions on Industrial Electronics, Vol. 54, No.6, Dec. 2007, pp.3276-3286.
- [4] G. Spiazzi, P. Mattavelli, L. Rossetto, "Sliding Mode Control of DC-DC Converters", 4° Congresso Brasileiro de Elettronica de Potencia (COBEP) , Belo Horizonte, December 1997, pp. 59-68.
- [5] S. C. Tan, Y. M. Lai, M. K. H. Cheung, and C. K. Tse, On the practical design of a sliding mode voltage controlled buck converter, IEEE Trans. Power Electron., vol. 20, no. 2, pp. 425-437, Mar. 2005.
- [6] P. Mattavelli, L. Rossetto, G. Spiazzi, P. Tenti, "General-purpose sliding-mode controller for DC/DC converter applications", Proc. of IEEE Power Electronics Specialists Conf. (PESC), Seattle, June 1993, pp.60n9-615.
- [7] G. Spiazzi, P. Mattavelli, L. Rossetto, L. Malesani, "Application of Sliding Mode Control to Switch-Mode Power Supplies", Journal of Circuits, Systems and Computers (JCSC), Vol. 5, No. 3, September 1995, pp.337-354.
- [8] Hansruedi Bühler "Réglage par mode de glissement" Presses polytechniques romandes, 1986.
- [9] V. Utkin, J. Guldner, and J.X. Shi, "Sliding Mode Control in Electromechanical Systems". London, U.K.: Taylor and Francis, 1999.
- [10] H. Sira-Ramirez, "On the generalized PI sliding mode control of DC- to-DC power converters": A tutorial, Int. J. Control, vol. 76, no. 9/10, pp. 1018-1033, 2003.
- [11] S. C. Tan, Y. M. Lai, C. K. Tse, and M. K. H. Cheung, "A fixed-frequency pulse-width-modulation based quasi-sliding mode controller for buck converters", IEEE Trans. Power Electron., vol. 20, no. 6, pp. 1379-1392, Nov. 2005.
- [12] S. C. Tan, Y. M. Lai, and C. K. Tse, "A unified approach to the design of PWM based sliding mode voltage controller for basic DC-DC converters in continuous conduction mode", IEEE Trans. Circuits Syst. I, vol. 53, no. 8, pp. 1816-1827, Aug. 2006.