

# An Investigation of Short Circuit Analysis in Komag Sarawak Operations (KSO) Factory

M. H. Hairi, H. Zainuddin, M.H.N. Talib, A. Khamis, J. Y. Lichun

**Abstract**—Short circuit currents plays a vital role in influencing the design and operation of equipment and power system and could not be avoided despite careful planning and design, good maintenance and thorough operation of the system. This paper discusses the short circuit analysis conducted in KSO briefly comprising of its significances, methods and results. A result sample of the analysis based on a single transformer is detailed in this paper. Furthermore, the results of the analysis and its significances were also discussed and commented.

**Keywords**—Short circuit currents, Transformer fault current

## I. INTRODUCTION

**A**N efficient and reliable power system is a vital component of any industry especially in manufacturing industries. Hence, power system studies especially the short circuit analysis needs to be conducted to evaluate the power delivery and utilization operation efficiency.

Komag Sarawak Operations (KSO) was one of the sub companies of Komag USA (M) Sdn. It was a manufacturing industry that produces hard disks with the KSO facility producing thin aluminum disc media substrate. Since it is a manufacturing based industry, it is vital that KSO's electrical power system operates efficiently with minimal interruption as each interruption may cause interruptions to its production which leads to high losses.



Fig 1. Komag Sarawak Operations Plant in 1997 [1]

The KSO Plant is supplied with electrical energy with the two-11kV Feeder from the utility board Sarawak

The authors are with Faculty of Electrical Engineering Universiti Teknikal Malaysia Melaka, Locked Bag No. 1752, Durian Tunggal Post Office, 76109, Durian Tunggal, Melaka, Malaysia, (Phone: +606-555 2000; Fax: +606-331 6247; e-mail: hendra@utem.edu.my, hidayat@utem.edu.my, hairulnizam@utem.edu.my, alias@utem.edu.my, jeese.lichun.yong@utem.edu.my)

Electricity Supply Cooperation (SESCO) as its source of electrical power as shown in Fig 2. The supply voltage for the distribution system is then generated via transformers. Hence, the two 11kV main incoming feeders are then stepped down to 480V, 433V or 280V as required by the loadings with the transformers located in Transformer Room 1, Switch Room 2 and Switch Room 3. There are a total of 12 operating transformers and 3 spare transformers in KSO. These transformers range from 1000 kVA to 2000 kVA.

The investigation of short circuit analysis is motivated by the desire of KSO engineer to reevaluate the protection system and maintain the system's reliability. This is due to the fact that the current electrical system has never been revised and lack of proper documentation of load addition and system expansion since its establishment in 1997.[12]

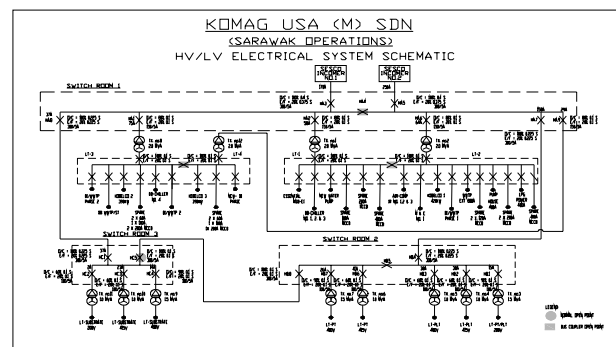

Fig. 2. KSO HV/LV Electrical System Schematic [2]

## II. SHORT CIRCUIT CURRENT SIGNIFICANCE

An electrical power system is always planned, designed, constructed and commissioned and operated to ensure optimum reliability, safety and economic supply. However, even the most flawless designed system could not avoid the occurrence of short circuits. This could be due to factors such as lightning surges and insulation failure caused by earth construction works and insulation aging.

According to IEC 60 909, a short circuit is the accidental or intentional conductive connection through a relatively low resistance or impedance between two or more points of a circuit which are normally at different potentials [3]. Short-circuit studies are conducted to determine the magnitude of the prospective currents flowing throughout the power system at various time intervals after a fault occurs.

The magnitude of the currents flowing through the power system after a fault varies with time until they reach a steady-state condition. This behavior is due to system characteristics and dynamics. During this time, the protective system is called on to detect, interrupt, and isolate these faults. The duty imposed on this equipment is

dependent upon the magnitude of the current, which is dependent on the time from fault inception. This is done for various types of faults (three phase, phase-to-phase, double-phase-to-ground, and phase-to-ground) at different locations throughout the system. The information is used to select fuses, breakers, and switchgear ratings in addition to setting protective relays [4].

Despite careful planning and design, excellent maintenance and thorough operation of the system, faults for example short circuits in power system are still unavoidable. It is vital that short circuit conditions be taken seriously as short circuit currents are usually many times greater than its rated currents, high dynamic and thermal stress and in certain cases, unacceptable voltages which may cause danger must be expected. Short circuit currents, according to IEC 60 909 results from a short circuit within an electrical network. The causes and effects of short circuit as listed in Table I

TABLE I  
CAUSES AND EFFECTS OF SHORT CIRCUITS

Causes	Effects
1. Over temperatures due to excessively high overcurrent	1. Power supply interruptions
2. Disruptive changes causes by overvoltage	2. System component damage or destruction
3. Arcing caused by moisture together with impure air especially on insulators	3. Development of unacceptable mechanical and thermal stresses in electrical operational equipment

The typical time course of a short-circuit current shown in the Fig 1. can be measured at high-voltage installations in the vicinity of power stations with synchronous generators, characterized by decaying ac and dc components of the current. It is assumed that the short-circuit is switched-off approximately 14 periods after its initiation which seems a rather long duration but was chosen for reason of a better visibility in the figure. The four parameters of the short-circuit current which would be focused on are as listed below [5].

A. Total Time Duration

The total time duration of the short-circuit current consists of the operating time of the protection devices and the total switchgear breaking time

B. Peak Short Circuit Current

The peak short-circuit time current, which is the maximal instantaneous value of the short-circuit current, occurs approximately a quarter period after the initiation of the short-circuit. As electromagnetic forces are proportional to the instantaneous current value, the peak short-circuit current is necessary to know in order to calculate the forces on conductors and construction parts affected by the short-circuit current.

C. r.m.s Value

The r.m.s.-value of the short-circuit current combined with the total time duration is a measure of the thermal effects of the short-circuit.

D. Short Circuit Breaking Value

The short-circuit breaking current is the r.m.s.-value of the short-circuit current at switching instant such as at circuit breaker operating time. While opening the contacts of the circuit breaker, the arc inside the breaker will heat up the installation, which also depends on the breaking time.

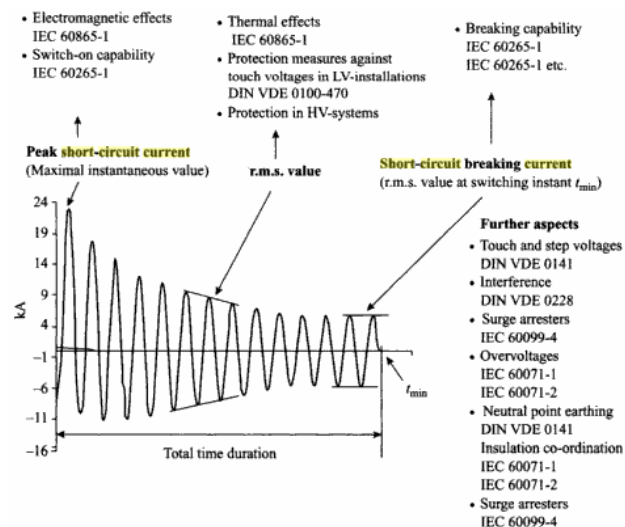

Fig 1. Importance of short-circuit currents and definition of tasks as per IEC 60781, IEC 60865, IEC 60909 and IEC 61660

III. SHORT CIRCUIT ANALYSIS AND TECHNIQUES

A balanced 3-phase also known as symmetrical or balanced fault implies that all three phases of the power system are simultaneously short-circuited to each other through a direct or "bolted" connection [6]. Although the probability of this happening is small, relative to the probability of other types of unbalanced faults occurring (phase-to-ground and phase-to-phase faults), nevertheless the balanced 3-phase fault calculation method is used for the short-circuit study for the following reason [7]:

- i. 3-phase fault produces the largest short-circuit current magnitude. Hence, this worst-case result is then used as the basis to select the short-circuit capabilities of switchgear from manufacturers' tables.
- ii. The simplest short-circuit calculations method because symmetry of the fault connection permits us to consider only one of the three phases.

The other types of unbalanced short-circuit faults are important in selecting the time-current characteristics and settings of phase-overcurrent and ground-fault protective devices to provide selective coordination. This coordination assures service continuity and minimizes damage to switchgear and load equipment. However, unbalanced fault calculations are more difficult to perform for industrial and commercial power systems and require knowledge of the method of symmetrical components.

The 3-phase fault current calculation basically uses the normal circuit theory methods which are very simple and easy to use. Basically, two methods of 3-phase fault calculation will be employed; MVA<sub>F</sub> method and I<sub>nominal</sub>. However, the availability of computer based power system analysis programs have enabled easier and simpler short

circuit analysis procedures and it is more widely used in complex networks as it is less time consuming.

#### A. $MVA_F$ Method

The  $MVA_F$  method is a modification of the Ohmic method where the impedance of a circuit equals the sum of the impedances of components constituting the circuit [8]. Using the admittances, it follows that the reciprocal of the system impedance is the sum of the reciprocals of the admittances of the components. By very definition, the circuit component admittance is the maximum current or KVA at unit voltage which would flow through the circuit or component to a short circuit or fault when supplied from a source of infinite capacity.

The calculation of the MVA fault,  $MVA_F$  and fault current,  $I_F$  can be performed with the following equations [9 & 10].

$$MVA_F = \sqrt{3} \times V_{line} \times I_F \quad (1)$$

$$\text{or } MVA_F = \frac{MVA_B}{Z_{pu}} \quad (2)$$

Where  $MVA_B$  is the MVA base and  $Z_{pu}$  is the impedance between the supply source and the fault location in per unit.

Hence, the three-phase fault current can be determined using equation (3).

$$I_F = \frac{MVA_F}{\sqrt{3} V} \quad (3)$$

#### B. $I_{nominal}$ Method

This method is employed when the magnitudes of the nominal current and total impedance in per unit are known and it is very straight forward and simple. Hence, the fault current can be determined by dividing the magnitude of the nominal current with the total impedance in per unit as given in equation (4).

$$I_F = \frac{I_{no\ min\ al}}{Z_{pu}} \quad (4)$$

Where,  $I_{nominal}$  = Rated current in ampere, and  
 $Z_{pu}$  = Total impedance in per unit

$$\text{Or; } I_F = \frac{V_S}{\sqrt{3} Z_{pu}} \quad (5)$$

$$\text{Total Impedance, } Z_{pu} = Z_S + Z_R \quad (3.11)$$

Where,  $V_S$  = Source voltage

$Z_S$  = Source impedance in per unit

$Z_R$  = Impedance of protected element in per unit

#### C. Computer Aided Short Circuit Analysis

There are many computer aided power system analysis programs that are equipped with comprehensive analysis platform for the design, simulation and operation of industrial power system. The short circuit analysis function is the fundamental or basic functions that are available in almost all computer aided power system analysis programs. These programs are available in the market and are utilized by engineers to conduct in house analyses in the comfort of their own workplace either at home or in the office using a personal computer.

#### IV. ESTIMATION OF TRANSFORMER FAULT CURRENT

The transformer fault current was calculated both manually and using the Transformer Fault Current Calculator. Samples of the calculations for Transformer T1 are as shown below based on its rated values of:

$$\begin{aligned} S &= 2.0 \text{ MVA} \\ V &= 11\text{k} / 433\text{V} \\ I &= 104.97 / 2666.8 \text{ A} \\ Z &= 5.93\% \end{aligned}$$

#### A. $MVA_F$ Method

Using Equation (2),

$$MVA_{F(T1)} = \frac{MVA_B}{Z_{pu}} = \frac{2.0\text{M}}{0.0593} = 33.726 \text{ MVA}$$

Using Equation (3),

$$I_{F,primary(T1)} = \frac{MVA_F}{\sqrt{3} V_p} = \frac{33.726\text{M}}{\sqrt{3} \times 11\text{k}} = 1770.16\text{A}$$

$$I_{F,secondary(T1)} = \frac{MVA_F}{\sqrt{3} V_p} = \frac{33.726\text{M}}{\sqrt{3} \times 433} = 44970.4\text{A}$$

#### B. $I_{nominal}$ Method

Using Equation (4),

$$I_{F,primary(T1)} = \frac{I_{no\ min\ al}}{Z_{pu}} = \frac{104.97}{0.0593} = 1770.15\text{A}$$

$$I_{F,secondary(T1)} = \frac{I_{no\ min\ al}}{Z_{pu}} = \frac{2666.8}{0.0593} = 44971.33\text{A}$$

#### C. Transformer Fault Current Calculator

After analyzing the Transformer Fault Current Calculator [11], it was discovered that the secondary fault current was calculated using equation (6) below:

Secondary Transformer Fault Current,

$$I_{Fault} = \frac{a I_{PF}}{\left(1 + \frac{\sqrt{3} V_P I_{PF} Z}{100 S}\right)} + 4I_{FL,in} + 5I_{FL, sync} \quad (6)$$

Where,

$a$  = Ratio ( $V_p / V_s$ )

$I_{PF}$  = Available primary fault current

$V_P$  = Primary voltage

$Z$  = Transformer impedance in %

$S$  = Transformer Rating (MVA)

$I_{FL, in}$  = Full load current of induction machines

$I_{FL, sync}$  = Full load current of synchronous machines

The results of the secondary transformer fault currents are as shown in Fig 1.. A sample calculation of the secondary transformer fault current based on Transformer T1 is as shown below.

Transformer T1 parameters;

$I_{PF} = 20\text{kA} V = 11\text{k}/433\text{V}$

$S = 2.0 \text{ MVA } Z = 5.93\%$

$I_{FL, induction} = I_{FL, synchronous} = 0\text{A}$

$$\therefore I_{Fault(T1)} = \frac{\left(\frac{11k}{433}\right) \times 20k}{\left(1 + \frac{\sqrt{3} \times 11k \times 20k \times 5.93}{100 \times 2M}\right)} = 41313.728A$$

TRANSFORMER FAULT CURRENT REPORT									
Transformer Designation	KVA Rating	Primary Voltage (V)	Secondary Voltage (V)	Transformer Impedance (%)	Number of Phases	Available Primary Fault (I)	Induction Motors FLA (I)	Synchronous Motors FLA (I)	Fault Current (A)
T1	2,000	11,000	433	5.93	3	20,000	0	0	41,314
T2	2,000	11,000	433	5.90	3	20,000	0	0	41,507
T3	1,500	11,000	208	5.84	3	20,000	0	0	66,792
T4	1,000	11,000	433	5.94	3	20,000	0	0	21,498
T5	1,000	11,000	480	5.80	3	20,000	0	0	19,840
T6	1,000	11,000	433	5.94	3	20,000	0	0	21,498
T7	1,500	11,000	480	5.90	3	20,000	0	0	28,667
T8	2,000	11,000	433	5.90	3	20,000	0	0	41,507
T9	1,500	11,000	480	5.90	3	20,000	0	0	28,667
T10	1,000	11,000	433	5.90	3	20,000	0	0	21,637
T11	1,000	11,000	208	5.90	3	20,000	0	0	48,043
T12	2,000	11,000	433	5.90	3	20,000	0	0	41,507

Fig 1. Transformer Fault Current Report

D. Comparison of Transformer Fault Current Results

Fig 2. shows the fault current of the secondary side of all the 12 operating transformers in KSO. It can be observed that the results obtained by all 3 methods are almost similar. Method 1 would be fault calculation using the  $MVA_{Fault}$  Calculation, Estimation Method using  $I_{nominal}$  for Method 2 while Method 3 would be calculation using the Transformer Fault Current Calculator.

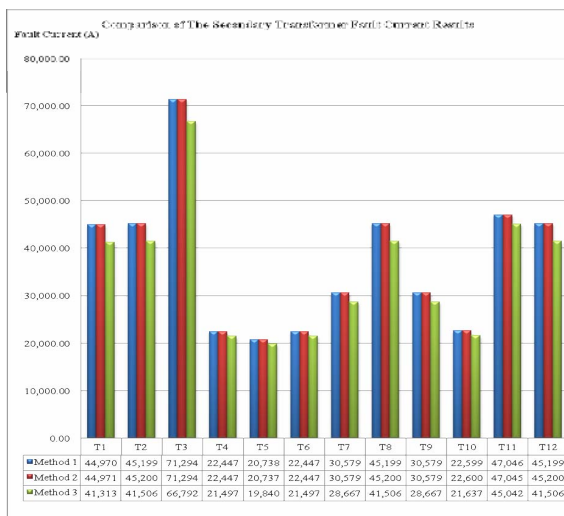

Fig. 2. Comparison of the secondary transformer fault current results

V. BUSBAR FAULT LEVEL

A. Manual Calculation

The fault levels are calculated with the equations listed in sub-chapter 3.3.2. The results obtained are used in the protection coordination analyses. Based on the feedback from KSO Facilities Engineer and SESCO, the fault level at both the 11kV incoming feeders are approximately 20-25kA. For calculation purpose, an estimation of 20kA will be selected. Therefore, the  $MVA_F$  at both the 11kV feeders are:

$$MVA_F = \sqrt{3} \times V \times I_F \tag{7}$$

$$= \sqrt{3} \times 11k \times 20k = 381.051MVA$$

The source and transformer impedances are required for the calculation of the fault levels. The source impedances are calculated as follow:

$$Z_{source} = \frac{V^2}{MVA_F} \tag{8}$$

$$= \frac{11k^2}{381.051M} = 0.31754\Omega$$

The actual transformer impedances can be calculated using the following equations:

$$Z_T = Z_{pu} \times Z_B \tag{9}$$

$$= Z_{pu} \times \frac{V_B^2}{MVA_B} \tag{10}$$

The actual impedances of all the 12 operating transformers are as shown in Table I.

TABLE I  
ACTUAL TRANSFORMER IMPEDANCES VALUE

Txf	S (MVA)	V <sub>p</sub> (kV)	V <sub>s</sub> (V)	Z (%)	Z <sub>T,primary</sub> (Ω)	Z <sub>T,secondary</sub> (Ω)
T1	2.0	11	433	5.93	3.5877	0.0056
T2	2.0	11	433	5.90	3.5695	0.0055
T3	1.5	11	208	5.84	4.7109	0.0017
T4	1.0	11	433	5.94	7.1874	0.0111
T5	1.0	11	480	5.80	7.0180	0.0134
T6	1.0	11	433	5.94	7.1874	0.0111
T7	1.5	11	480	5.90	4.7593	0.0091
T8	2.0	11	433	5.90	3.5695	0.0055
T9	1.5	11	480	5.90	4.7593	0.0091
T10	1.0	11	433	5.90	7.1390	0.0111
T11	1.0	11	208	5.90	7.1390	0.0026
T12	2.0	11	433	5.90	3.5695	0.0055

Sample of calculations of the actual impedances of T1 referring to both primary and secondary side using Equation (10);

$$Z_{T1,primary} = 0.0593 \times \frac{11k^2}{2M} = 3.58765\Omega$$

$$Z_{T1,secondary} = 0.0593 \times \frac{433^2}{2M} = 0.005559\Omega$$



The fault levels at each busbar can be calculated with the Equation (11).

$$I_F = \frac{V_S}{\sqrt{3} Z_{total}} \quad (11)$$

Where  $Z_{total}$  = Summation of source impedance and protected element impedance

A sample of calculation of fault levels from SESCO Incomer No.1 to transformer T1 is as shown below.

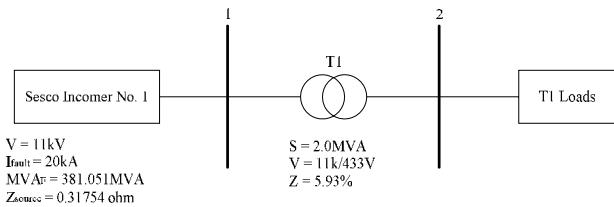

Fig. 3. Single line diagram showing T1 connections

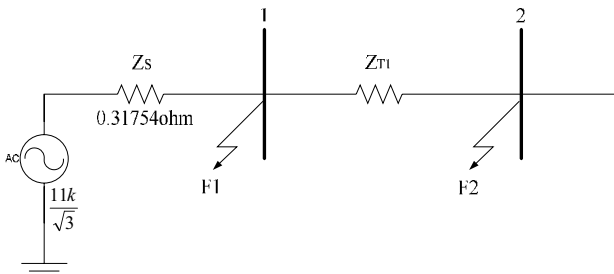

Fig. 4. Illustration showing the fault levels based on Fig 3.

Using Equation (11),

Fault current at busbar 1,  $I_{F1} = \frac{11k}{\sqrt{3} \times 0.31754} = 20kA$

Fault current at busbar 2,

$$I_{F2} = \frac{11k}{\sqrt{3} \times (0.31754 + 3.58765)} = 1.626kA @ 11kV,$$

$$= 1.626k \times \frac{11000}{433} = 41.314kA @ 433V.$$

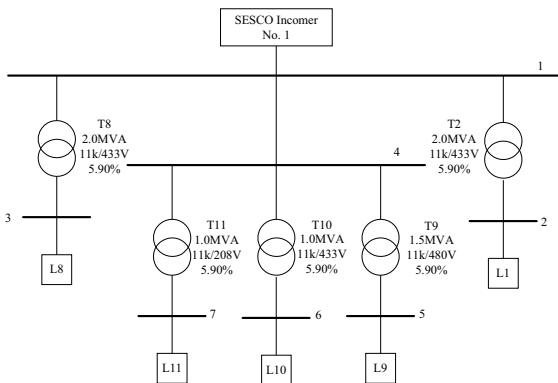

Fig 5. Single-line diagram of KSO electrical distribution system supplied by SESCO Incomer No. 1

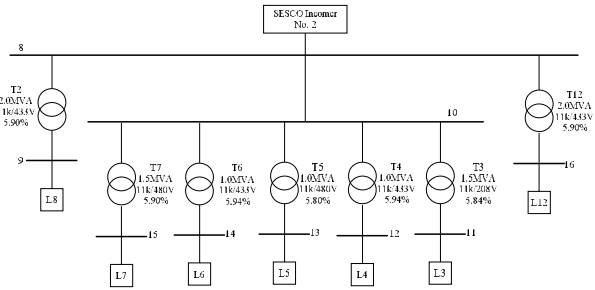

Fig. 6. Single-line diagram of KSO electrical distribution system supplied by SESCO Incomer No. 2

The calculation results of fault levels at each busbar in Fig 5. and Fig 6. are as shown in Table II.

TABLE II  
FAULT LEVEL RESULTS (MANUAL CALCULATIONS)

System Voltage Level	Fault Location (Busbar)	Fault Level / I <sub>Short-Circuit</sub> (A)
11kV	1	20 kA
433V	2	1.626 kA (referred to 11kV) 41.314 kA (referred to 433V)
433V	3	1.634 kA (referred to 11kV) 41.506 kA (referred to 433V)
11kV	4	20 kA
480V	5	1.251 kA (referred to 11kV) 28.668 kA (referred to 480V)
208V	6	851.716 A (referred to 11kV) 45.043 kA (referred to 208V)
433V	7	851.716 A (referred to 11kV) 21.637 kA (referred to 433V)
11kV	8	20 kA
433V	9	1.634 kA (referred to 11kV) 41.507 kA (referred to 433V)
11kV	10	20 kA
208V	11	1.263 kA (referred to 11kV) 66.793 kA (referred to 208V)
433V	12	846.223 A (referred to 11kV) 21.498 kA (referred to 433V)
480V	13	845.765 A (referred to 11kV) 19.840 kA (referred to 480V)
433V	14	846.223 A (referred to 11kV) 21.495 kA (referred to 433V)
433V	15	1.251 kA (referred to 11kV) 28.667 kA (referred to 480V)
433V	16	1.634 kA (referred to 11kV) 41.507 kA (referred to 433V)

**B. Simulation Results**

Fault analysis was also conducted using the ETAP 5.5.5 Demo Version's Short-Circuit Analysis function. A sample of T1's short circuit analysis results are as shown below:

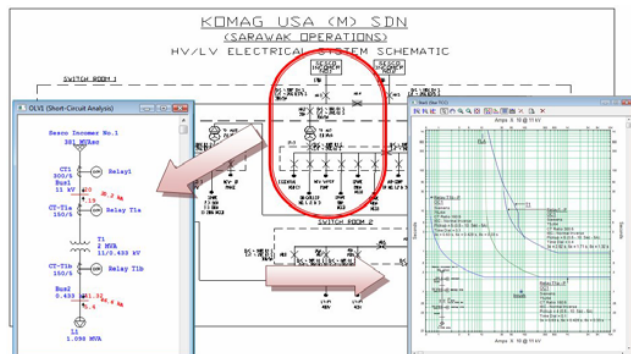

Fig. 7. ETAP Simulations (From Feeder 1 SESCO Incomer 1 to L1)

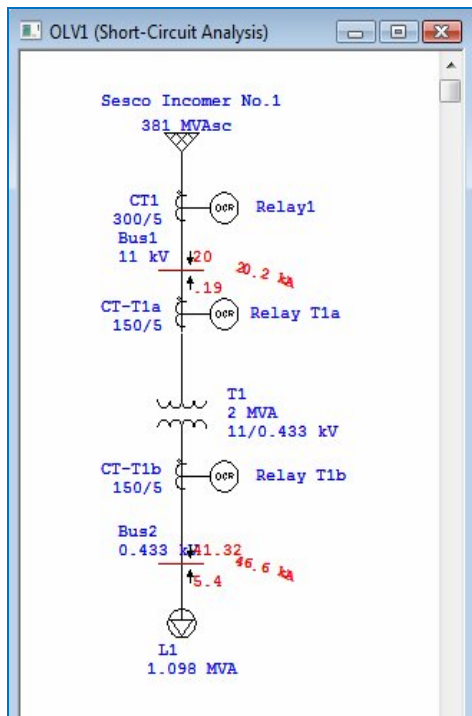

Fig. 8. Short circuit analysis results for circuit Sesco Incomer No.1 to L1

## VI. DISCUSSION

From the analysis and simulations made above, the following conclusions can be made:

1) The maximum fault current can be predicted and calculated based on the rated values of the connected equipments and loadings

2) The obtained fault current values are deemed to be accurate as the manual calculation results are almost equivalent to the simulated results. The differences in values are mainly due to the impedance factor.

3) The obtained fault level at the busbars (Busbar 1-16 – refer to Fig. 5 and 6. connected to the transformer's secondary side are approximately similar to the calculated transformer fault currents at the secondary windings as they are basically located at the same locations. This is because the fault level at busbar 2 and the secondary winding transformer fault current are located at the same location.

4) Furthermore, it was observed that the simulated fault levels at the transformer's also differs but with a slight difference. The differences in the results are due to the fact that in the simulation analyses, the program takes the impedances of the entire circuit into the account. Hence, the load impedances are also accounted for in the analyses unlike the two other calculation methods.

5) The simulated results of fault current were observed to be generally higher than the calculated values. Basically, the difference in results was caused by the impedance consideration factor. In the simulation, the ETAP program takes the load impedance into account causing a difference in the short circuit analysis results. Furthermore, the type of load selected for the system was the lumped load where the power factor and the efficiency of the system are also considered by the program.

## VII. CONCLUSION

The fault analysis plays a vital role in a power system analysis as it is used in determining the appropriate protection scheme for a power system. The calculated fault current or short circuit current based on the rated equipment values are used in determining the minimum protection requirement as the obtained fault current is the maximum fault current that may occur within the system. Hence, this would enable sufficient protection. After all, short circuit currents are normally quite excessively high and potentially deadly and hazardous to both equipments and personnel. Thus, the obtained fault levels in this paper acts as the prerequisite to protection coordination studies in KSO.

## REFERENCES

- [1] Kho, H. *PowerPoint Slides: KSO Overview*, 2007.
- [2] J., L. Yong, *KSO Contingency Plan Rev. IV*, 2007, p. 1-107.
- [3] I. Kasikci, *Short Circuit in Power Systems: A Practical Guide to IEC 60 909* Germany: Wiley VCH, 2002, p. 1-102.
- [4] *IEEE Recommended Practice for Industrial and Commercial Power System Analysis (IEEE Brown Book)*, IEEE Standard 399-1997.
- [5] J. Schlabbach, *Short Circuit Currents: IEE Power & Energy Series 51*.UK: IEE, 2005, p.67-94.
- [6] J. D. Glover and M. S. Sarma, *Power System Analysis and Design*. Third Edition. USA: Brooks/Cole Thomson Learning, 2002, p. 608-610.
- [7] Chu & Gassman Consulting Engineers, "*Short-Circuit Calculation Methods*", *EC & M*. [Online]. Available: [http://ecmweb.com/mag/electric\\_shortcircuit\\_calculation\\_methods/](http://ecmweb.com/mag/electric_shortcircuit_calculation_methods/)
- [8] J. Frank, "*How to Perform Short-Circuit Calculations*", *EC & M* [Online]. Available: [http://ecmweb.com/mag/electric\\_perform\\_shortcircuit\\_calculations\\_3/](http://ecmweb.com/mag/electric_perform_shortcircuit_calculations_3/)
- [9] Rahim Bin Hj. Selamat, "*Menganalisa Pembezaan dan Penatahan Perlindungan Arus Lampau dan Kerosakan Ke Bumi Pada Rangkaian Sistem Pengagihan Voltan Rendah*", Malacca: UTeM, 2005, p. 10-46.
- [10] K. S. Wong, *Power Distribution and Protection*. Second Edition. Singapore: Pearson Prentice Hall, 2003, p. 14-31.
- [11] *Electrical Engineering Programs* [Online]. Available: <http://newcalc.com/engineering-software.htm>
- [12] Duncan Lee Chian Kok, Facilities Engineer Komag Sarawak Operation.