

# A Heat-Inducible Transgene Expression System for Gene Therapy

Masaki Yamaguchi, Akira Ito, Noriaki Okamoto, Yoshinori Kawabe, and Masamichi Kamihira

**Abstract**—Heat-inducible gene expression vectors are useful for hyperthermia-induced cancer gene therapy, because the combination of hyperthermia and gene therapy can considerably improve the therapeutic effects. In the present study, we developed an enhanced heat-inducible transgene expression system in which a heat-shock protein (HSP) promoter and tetracycline-responsive transactivator were combined. When the transactivator plasmid containing the tetracycline-responsive transactivator gene was co-transfected with the reporter gene expression plasmid, a high level of heat-induced gene expression was observed compared with that using the HSP promoter without the transactivator. In vitro evaluation of the therapeutic effect using HeLa cells showed that heat-induced therapeutic gene expression caused cell death in a high percentage of these cells, indicating that this strategy is promising for cancer gene therapy.

**Keywords**—Inducible gene expression, Gene therapy, Hyperthermia, Heat shock protein, Tetracycline transactivator.

## I. INTRODUCTION

**S**PATIAL and temporal control of therapeutic gene expression is a major goal in gene therapy. Therefore, various inducible vectors have been employed for cancer gene therapy. Moreover, a combination of chemotherapy, radiotherapy or hyperthermia with gene therapy using a corresponding inducible vector considerably enhances therapeutic efficacy [1]-[3]. The multimodal combination approach has been successfully utilized for controlled expression of tumor-toxic genes, including tumor necrosis factor (TNF)- $\alpha$  [1], [2] or herpes simplex virus thymidine kinase (HSV-tk) followed by ganciclovir (GCV) exposure for suicide gene therapy [3].

Hyperthermia has been used to treat patients with various types of cancer [4], [5]. Moreover, hyperthermia has often been used in combination with radiotherapy, chemotherapy and immunotherapy [6]. Therefore, the combination of

hyperthermia with heat-induced gene therapy is a promising strategy. This strategy could be greatly useful if therapeutic genes that enhance the efficacy of hyperthermia at both the cellular and systemic levels are expressed (Fig. 1). To achieve this, several heat-inducible promoters, such as heat-shock protein (HSP) promoter and growth arrest and DNA damage (GADD) 153 promoter, have been exploited for the construction of viral and non-viral vectors with heat-inducible gene expression in gene therapy researches [7], [8]. The HSPs, molecular chaperones that play an important role in inhibition of aggregation of cellular proteins are induced by various cellular damages including heating [9]. Among those, HSP70B' is a human HSP70 chaperone that is reported to be strictly inducible, exhibiting very low basal expression levels [10]. However, HSP70 promoters are not as strong as the constitutively active viral promoters [11]. Thus, it is essential to find ways to enhance the transcriptional activity of HSP70 promoters.

Tetracycline (Tet)-controlled expression systems have been used successfully in many cell types and in transgenic animals [12]. The Tet-Off system consists of a combination of two vectors, one for constitutively expressing Tet-responsive transcriptional activator (transactivator) protein (tTA) and the other for expressing a gene of interest under the control of the minimal cytomegalovirus (CMV) promoter (PCMVmini) containing a binding site, the Tet response element (TRE), for tTA. If cells are transfected with the two vectors, the transcription of the transgene is highly activated by tTA. To combine heat-inducibility with high-level transgene expression, we developed a heat-inducible transgene expression system mediated by tTA. A hybrid promoter, TRE-HSP, was generated by placing the HSP70B' promoter under the TRE sequence, and a reporter or therapeutic gene expression plasmid was constructed by placing a reporter gene (*LacZ*) or a therapeutic gene (*TNF- $\alpha$*  or *HSV-tk*) under the control of the hybrid promoter. The transactivator plasmid containing an expression cassette of the tTA gene was co-transfected with the reporter/therapeutic gene expression plasmid, we investigated whether heat-inducible expression by the TRE-HSP promoter was enhanced by tTA. The *in vitro* therapeutic effect was also evaluated using HeLa cells.

M. Yamaguchi is with the Department of Chemical Engineering, Faculty of Engineering, Kyushu University, 744 Motoooka, Nishi-ku, Fukuoka 819-0395, Japan (e-mail: 3TE12035Y@s.kyushu-u.ac.jp).

A. Ito is with the Department of Chemical Engineering, Faculty of Engineering, Kyushu University, 744 Motoooka, Nishi-ku, Fukuoka 819-0395, Japan (e-mail: akira@chem-eng.kyushu-u.ac.jp).

N. Okamoto was with the Department of Chemical Engineering, Faculty of Engineering, Kyushu University, 744 Motoooka, Nishi-ku, Fukuoka 819-0395, Japan (e-mail: 2TE10129Y@s.kyushu-u.ac.jp).

Y. Kawabe is with the Department of Chemical Engineering, Faculty of Engineering, Kyushu University, 744 Motoooka, Nishi-ku, Fukuoka 819-0395, Japan (e-mail: kawabe@chem-eng.kyushu-u.ac.jp).

M. Kamihira is with the Department of Chemical Engineering, Faculty of Engineering, Kyushu University, 744 Motoooka, Nishi-ku, Fukuoka 819-0395, Japan (phone: +81-92-802-2743; fax: +81-92-802-2793; e-mail: kamihira@chem-eng.kyushu-u.ac.jp).

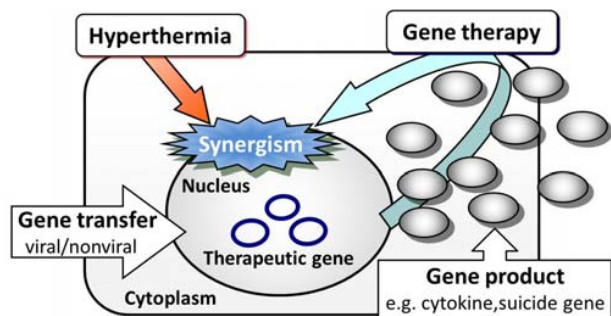

Fig. 1 Schematic representation of heat-induced gene therapy

## II. MATERIALS AND METHODS

### A. Plasmid Construction

A human HSP70B' promoter sequence fragment was obtained from HEK293 cells by polymerase chain reaction (PCR). The reporter or therapeutic gene expression plasmids were constructed by combining the HSP70B' promoter with the Tet-Off system (Fig. 2).

### B. Cell Culture

The human cervical cancer cell line HeLa, was grown in Dulbecco's modified Eagle's medium supplemented with 10% fetal bovine serum, 100 U/mL penicillin G potassium and 0.1 mg/mL streptomycin sulfate. Cells were cultured at 37°C in a 5% CO<sub>2</sub> incubator.

### C. Reporter Gene Assay

HeLa cells were co-transfected with both the reporter gene expression plasmid (pTRE-HSP/Z) and the transactivator plasmid (pCMV/tTA) using Lipofectamine 2000 (Invitrogen). As a control experiment without the transactivator plasmid, pETBlue plasmid (Novagen) was used as a mock plasmid and co-transfected with the reporter gene expression plasmid. Heat shock treatment was performed at 1 day post-transfection. The cell culture dishes were sealed and directly immersed in a water bath at 41, 43 or 45°C for 1 h. Following heat treatment, the cell culture dishes were immediately returned to the CO<sub>2</sub> incubator at 37°C, and cells were harvested periodically to quantify β-galactosidase activity [13].

### D. Cytotoxic Assay using TNF-α Gene Expression Plasmid

HeLa cells were co-transfected with both pCMV/tTA and the therapeutic gene expression plasmid (pTRE-HSP/α) using Lipofectamine 2000 (Invitrogen). As a control experiment, the pETBlue plasmid (Novagen) was used as the mock plasmid. Heat shock treatment was performed 1 day post-transfection. After heat treatment, cells were collected and incubated at 37°C for 24 h in the CO<sub>2</sub> incubator. To evaluate the cytotoxicity, the viable cell count was estimated by the trypan blue dye-exclusion method using a hemocytometer. Statistical comparisons were performed using the Mann-Whitney rank sum test. Differences in statistical comparisons were considered significant at levels of *P* values < 0.05.

### E. Cytotoxic Assay using HSV-tk Gene Expression Plasmid

HeLa cells were co-transfected with both pCMV/tTA and pTRE-HSP/tk using Lipofectamine 2000 (Invitrogen). As a control experiment, the pETBlue plasmid (Novagen) was used as the mock plasmid. Heat shock treatment was performed 1 day post-transfection. After heat treatment, cells were collected and reseeded in fresh culture medium containing GCV (0.1 μg/ml), and incubated at 37°C for 48 h in a CO<sub>2</sub> incubator. Cytotoxicity was evaluated using a Cell counting kit-8 (Dojindo), based on the WST-8 method, according to the manufacturer's protocol. Statistical comparisons were performed using the Mann-Whitney rank sum test. Differences in statistical comparisons were considered significant at levels of *P* values < 0.05.

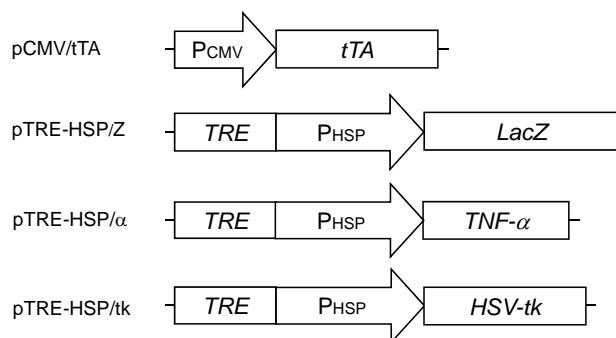

Fig. 2 Plasmid vectors used in this study

## III. RESULTS

### A. Reporter Gene Expression under Various Temperatures

Table I shows the relative β-galactosidase activities at 6 and 24 h after heat treatment with different temperatures. Without heat treatment, when cells were co-transfected with pTRE-HSP/Z and pCMV/tTA, the β-galactosidase activity was 6–7 times higher than without the transactivator expression plasmid (pTRE-HSP/Z alone), although the expression level was considerably lower (data not shown). When the cells were treated at 41, 43 or 45°C, higher levels of heat-induced gene expression were observed by co-transfection with the plasmids. The time-course profile of reporter gene expression was different, especially between cells that underwent heat treatment at 43 and 45°C. For the cells heated at 45°C, reporter gene expression was low at 6 h, but then increased dramatically (Table I). This suggested that the activity of the HSP70B' promoter was inhibited until 6 h after heat treatment because of severe stress and cellular damage by heating at 45°C. Promoter activity was subsequently induced as cells recovered from the damage. These results show that the hybrid promoter system possessed both the heat-inducible property of the HSP70B' promoter and the high-level expression property of the Tet system.

TABLE I  
REPORTER GENE EXPRESSION DRIVEN BY THE HYBRID PROMOTER

6 h		
Temperature (°C)	Plasmid vector	Relative $\beta$ -galactosidase activity (-)
37	pTRE-HSP/Z	0.85 $\pm$ 0.18
	pTRE-HSP/Z pCMV/tTA	6.9 $\pm$ 0.6
41	pTRE-HSP/Z	2.2 $\pm$ 0.4
	pTRE-HSP/Z pCMV/tTA	19.3 $\pm$ 1.5
43	pTRE-HSP/Z	522 $\pm$ 64
	pTRE-HSP/Z pCMV/tTA	831 $\pm$ 138
45	pTRE-HSP/Z	1.5 $\pm$ 0.1
	pTRE-HSP/Z pCMV/tTA	8.1 $\pm$ 0.1
24 h		
Temperature (°C)	Plasmid vector	Relative $\beta$ -galactosidase activity (-)
37	pTRE-HSP/Z	0.76 $\pm$ 0.08
	pTRE-HSP/Z pCMV/tTA	6.1 $\pm$ 0.3
41	pTRE-HSP/Z	1.1 $\pm$ 0.2
	pTRE-HSP/Z pCMV/tTA	15.4 $\pm$ 0.7
43	pTRE-HSP/Z	294 $\pm$ 83
	pTRE-HSP/Z pCMV/tTA	401 $\pm$ 124
45	pTRE-HSP/Z	561 $\pm$ 100
	pTRE-HSP/Z pCMV/tTA	1115 $\pm$ 148

Relative  $\beta$ -galactosidase activity of the cells transfected with pTRE-HSP/Z alone without heating (37°C) at 0 h was defined to be 1. The data are expressed as mean  $\pm$  SD (n=3).

#### B. Effect of Enhanced Heat-inducible TNF- $\alpha$ Gene Expression on HeLa Cells

When HeLa cells were co-transfected with pCMV/tTA and pTRE-HSP/ $\alpha$ , the basal levels of TNF- $\alpha$  production were kept at low levels ( $\sim$ 0.1 pg/cell), and no significant reduction in cell viability was observed (Table II). For heat treatment at 43°C for 1 h, the cell viability of the mock transfected HeLa cells was 71.0  $\pm$  8.1%. Cell viability was drastically decreased by heat treatment at 45°C for 1 h, and the cell viability was 23.5  $\pm$  2.1%. When the cells were transfected with pTRE-HSP/ $\alpha$  and underwent heat treatment at 43°C for 1 h, heat-inducible gene expression occurred (Table I) and the cell viability decreased to 59.7  $\pm$  3.7% (Table II). The production of TNF- $\alpha$  was enhanced by co-transfection with the transactivator plasmid (pTRE-HSP/ $\alpha$  + pCMV/tTA). The cell viability after heat treatment was significantly ( $P < 0.05$ ) decreased to 36.5  $\pm$  3.3% (Table II). For heat treatment at 45°C for 1 h, gene expression

was also enhanced by co-transfection of the plasmids (Table I), and the cell viability decreased to 2.4  $\pm$  0.2% (Table II).

TABLE II  
IN VITRO CYTOTOXIC EFFECTS OF HEAT-INDUCIBLE TNF-ALPHA GENE EXPRESSION ON HeLA CELLS

Temperature (°C)	Plasmid vector	Cell viability (%)
37	Mock	100 $\pm$ 4.3
	pTRE-HSP/ $\alpha$	107 $\pm$ 4.6
	pTRE-HSP/ $\alpha$ pCMV/tTA	106 $\pm$ 4.3
43	Mock	71.0 $\pm$ 8.1
	pTRE-HSP/ $\alpha$	59.7 $\pm$ 3.7
	pTRE-HSP/ $\alpha$ pCMV/tTA	36.5 $\pm$ 3.3
45	Mock	23.5 $\pm$ 2.1
	pTRE-HSP/ $\alpha$	14.2 $\pm$ 1.2
	pTRE-HSP/ $\alpha$ pCMV/tTA	2.4 $\pm$ 0.2

The cell viability was determined as follows: Cell viability (%) = 100  $\times$  (number of viable cells in the tested dish) / (number of viable cells in the mock vector control dish at 37°C). The data are expressed as mean  $\pm$  SD (n=3).

#### C. Effect of Enhanced Heat-inducible Suicide Gene Therapy on HeLa Cells

The cytotoxic effect of HSV-tk gene therapy can be regulated by two factors, HSV-tk gene expression level and GCV concentration. In the present study, HeLa cells were transfected with pTRE-HSP/tk followed by GCV exposure at a fixed GCV concentration (0.1  $\mu$ g/ml). A criterion in the present study was low cytotoxicity caused by basal level expression of a therapeutic gene at 37°C. To achieve good treatment efficacy, another criterion was a significantly greater percentage of cell death under clinically acceptable GCV concentrations. As shown in Table III, when cells were co-transfected with pTRE-HSP/tk and pCMV/tTA followed by GCV exposure, slight cytotoxicity was observed at 37°C. For heat treatment at 43°C for 1 h, when cells were co-transfected with pTRE-HSP/tk and pCMV/tTA followed by GCV exposure, the cell viability was significantly decreased to 43.6  $\pm$  7.1% (Table III). For heat treatment at 45°C for 1 h, the cytotoxic effect on the co-transfected cells was significantly enhanced, and cell viability remarkably decreased to 8.7  $\pm$  0.8% (Table III).

TABLE III  
IN VITRO CYTOTOXIC EFFECTS OF HEAT-INDUCIBLE HSV-TK GENE  
EXPRESSION ON HELA CELLS

Temperature (°C)	Plasmid vector	Cell viability (%)
37	Mock	100 ± 2.8
	pTRE-HSP/tk	100 ± 3.3
	pTRE-HSP/tk pCMV/tTA	92.5 ± 2.6
43	Mock	75.7 ± 3.5
	pTRE-HSP/tk	69.4 ± 3.9
	pTRE-HSP/tk pCMV/tTA	43.6 ± 7.1
45	Mock	10.8 ± 0.2
	pTRE-HSP/tk	8.6 ± 0.9
	pTRE-HSP/tk pCMV/tTA	8.7 ± 0.8

The cell viability was determined as follows: Cell viability (%) =  $100 \times$  (number of viable cells in the tested dish) / (number of viable cells in the mock vector control dish at 37°C). The data are expressed as mean ± SD (n=3).

#### IV. DISCUSSION

We have developed and characterized a novel heat-inducible transcriptional amplification system, demonstrating that high-level of transgene expression mediated by the transactivator is induced by heat treatment without loss in the properties of the strict heat-inducible HSP70B' promoter. Such a regulation system could be potentially altered to include any desired transgene, ideal for gene therapeutic applications. This transcriptional regulation can be combined with localized hyperthermia systems to increase the specificity and the safety of cancer gene therapy. For cancer hyperthermia, magnetic nanoparticle-mediated hyperthermia has been a largely experimental modality. In recent years, remarkable advances in magnetite nanoparticle-mediated hyperthermia have been reported [14], [15]. With respect to heat-inducible gene therapy by the magnetite nanoparticles-mediated hyperthermia system, hyperthermia possesses two functions as a direct killer against tumor cells, and as a gene activation switch. In the present study the transactivator, tTA, was employed as the "second activator" in heat-inducible gene therapy, and we have established the enhanced heat-inducible gene expression system. This comprises the hybrid promoter with substandard leak and high-activation properties. These findings indicate that this strategy may improve the safety and efficacy of cancer gene therapy.

#### ACKNOWLEDGMENT

This work was supported in part by Grant-in-Aid for Scientific Research on Innovative Areas (No. 24119512) of the Ministry of Education, Culture, Sports, Science and Technology (MEXT), and in part by the "International Research Experience for Students and Young Researchers" of Kyushu University, Japan.

#### REFERENCES

- [1] W. Walther, J. Wendt, and U. Stein, "Employment of the *mdr1* promoter for the chemotherapy-inducible expression of therapeutic genes in cancer gene therapy," *Gene Ther.*, vol. 4, June 1997, pp. 544-552.
- [2] D.E. Hallahan, H.J. Mauceri, L.P. Seung, E.J. Dunphy, J.D. Wayne, N.N. Hanna, A. Toledano, S. Hellman, D.W. Kufe, and R.R. Weichselbaum, "Spatial and temporal control of gene therapy using ionizing radiation," *Nat. Med.*, vol. 1, August 1995, pp. 786-791.
- [3] R.V. Blackburn, S.S. Galoforo, P.M. Corry, and Y.J. Lee, "Adenoviral-mediated transfer of a heat-inducible double suicide gene into prostate carcinoma cells," *Cancer Res.*, vol. 58, April 1998, pp. 1358-1362.
- [4] M.W. Dewhirst, L. Prosnitz, D. Thrall, D. Prescott, S. Clegg, C. Charles, J. MacFall, G. Rosner, T. Samulski, E. Gillette, and S. LaRue, "Hyperthermic treatment of malignant diseases: current status and a view toward the future," *Semin Oncol.*, vol. 24, December 1997, pp. 616-625.
- [5] J. van der Zee, "Heating the patient: a promising approach?" *Ann. Oncol.*, vol. 13, August 2002, pp. 1173-1184.
- [6] P. Wust, B. Hildebrandt, G. Sreenivasa, B. Rau, J. Gellermann, H. Riess, R. Felix, and P.M. Schlag, "Hyperthermia in combined treatment of cancer," *Lancet Oncol.*, vol. 3, August 2002, pp. 487-497.
- [7] W. Walther, and U. Stein, "Heat-responsive gene expression for gene therapy," *Adv. Drug. Deliv. Rev.*, vol. 61, July 2009, pp. 641-649.
- [8] A. Ito, M. Shinkai, H. Honda, and T. Kobayashi, "Heat inducible TNF-alpha gene therapy combined with hyperthermia using magnetic nanoparticles as a novel tumor-targeted therapy," *Cancer Gene Ther.*, vol. 8, September 2001, pp. 649-654.
- [9] S. Lindquist, "The heat-shock response," *Ann. Rev. Biochem.*, vol. 55, July 1986, pp. 1151-1191.
- [10] T.K. Leung, M.Y. Rajendran, C. Monfries, C. Hall, and L. Lim, "The human heat-shock protein family. Expression of a novel heat-inducible HSP70 (HSP70B') and isolation of its cDNA and genomic DNA," *Biochem. J.*, vol. 267, April 1990, pp. 125-132.
- [11] K. Wada, A. Taniguchi, and T. Okano, "Highly sensitive detection of cytotoxicity using a modified HSP70B' promoter," *Biotechnol. Bioeng.*, vol. 97, July 2007, pp. 871-876.
- [12] M. Gossen, and H. Bujard, "Tight control of gene expression in mammalian cells by tetracycline-responsive promoters," *Proc. Natl. Acad. Sci. U.S.A.*, vol. 89, June 1992, pp. 5547-5551.
- [13] M. Kamihira, K. Ono, K. Esaka, K. Nishijima, R. Kigaku, H. Komatsu, T. Yamashita, K. Kyogoku, and S. Iijima, "High-level expression of single-chain Fv-Fc fusion protein in serum and egg white of genetically manipulated chickens by using a retroviral vector," *J. Virol.*, vol. 79, September 2005, pp. 10864-10874.
- [14] A. Ito, F. Matsuoka, H. Honda, and T. Kobayashi, "Antitumor effects of combined therapy of recombinant heat shock protein 70 and hyperthermia using magnetic nanoparticles in an experimental subcutaneous murine melanoma," *Cancer Immunol Immunother.*, vol. 53, January 2004, pp. 26-32.
- [15] A. Ito, M. Shinkai, H. Honda, and T. Kobayashi, "Medical application of functionalized magnetic nanoparticles," *J. Biosci. Bioeng.*, vol. 100, July 2005, pp. 1-11.