

CFD Modeling of High Temperature Seal Chamber

Mikhail P. Strongin, Ragupathi Soundararajan

Abstract—The purpose of this work is fast design optimization of the seal chamber. The study includes the mass transfer between lower and upper chamber on seal chamber for hot water application pumps. The use of Fluent 12.1 commercial code made it possible to capture complex flow with heat-mass transfer, radiation, Taylor instability, and buoyancy effect. Realizable k-epsilon model was used for turbulence modeling. Radiation heat losses were taken into account. The temperature distribution at seal region is predicted with respect to heat addition.

Results show the possibilities of the model simplifications by excluding the water domain in low chamber from calculations. CFD simulations permit to improve seal chamber design to meet target water temperature around the seal. This study can be used for the analysis of different seal chamber configurations.

Keywords—CFD, heat transfer, seal chamber, high temperature water

I. INTRODUCTION

KEEPING the water surrounding the standard seal below certain temperature and quick design cycle is the critical task on hot water application pumps. Earlier seal chamber design was done through a physical prototype and validated using the physical test. Setting up the test and visualizing the temperature distribution in the chamber is a very complex and time-consuming process.

In this case, CFD heat transfer modeling is the promising tool to solve this problem, because simulation allow us to get quick competitive design by viewing realistic flow and heat transfer [1 - 4]. The difficulty of using CFD for this analysis was related to the fact of incorporating complex heat-transfer mechanisms including radiation, buoyancy effects and so on. Here, choosing the right models of heat transfer, turbulence, and approximations is critical to describe the correct physical processes.

In presented work the CFD analysis of seal chamber has been done in coupling with heat-mass transfer analysis to take into account the major physical mechanisms that influence of the process.

II. MODEL DESCRIPTION

It is a vertical turbine pump where motor mounted on top of the pump and the motor fan cools the motor as well seal chamber, as shown on Fig 1. Fluent 12.1 commercial code was used for simulations. The seal chamber design involves the

following three modes for heat transfer: conduction, convection, and radiation. Buoyancy effect is taken into account with Boussinesq hypotheses. Radiation effect was taken into account through wall boundary conditions. On the wall – air boundaries for conjugate heat transfer model heat flux coupling have been:

$$-\lambda_w (\mathbf{n}\nabla) T_w = -\lambda_a (\mathbf{n}\nabla) T_a + \gamma \sigma (T_w^4 - T_0^4)$$

External emissivity γ here is 0.6. See details of these models in [5].

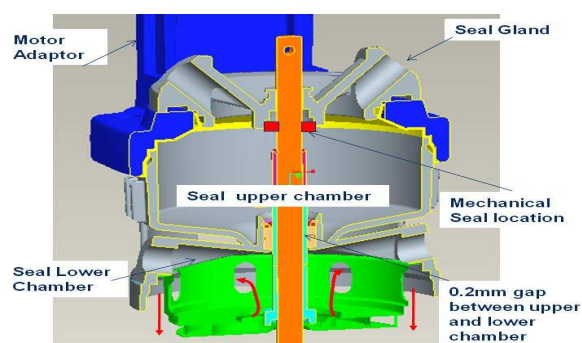

Fig. 1 Seal Chambers Geometry

Conjugate heat transfer approach is carried out with upper chamber water, metal and surrounding air. Ten million cells were used to capture the heat losses with buoyancy effect. The mesh is shown on Fig.2. Hot water enters the upper chamber through 0.2 mm gap and 12 mm depth passage. It is captured by very fine mesh(30x360x100) shown in Figure 3b.

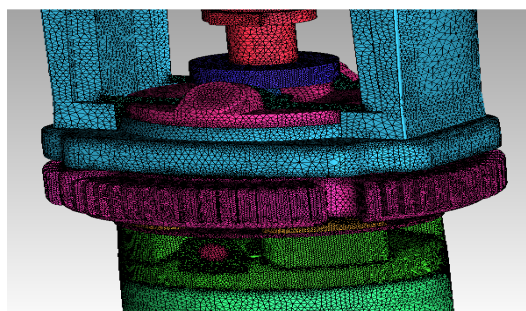

Fig. 2 Mesh for Case2

Linear viscosity model is used to capture the temperature-viscosity effect of water; incompressible ideal gas model is applied to surrounding air. A realizable k-epsilon model is chosen to capture the turbulence effect. Two cases were modeled.

In case 1, special study has been done to estimate convection heat mass transfer between two chambers due to a cross sectional gap between two chambers. Convection mode may play significant role in the transfer of heat from the lower

¹M. P. Strongin is with the Xylem RCW, Morton Grove, IL, USA (phone: 847-983-5528; fax: 847-966-9983; e-mail: mikhail.strongin@xylem.com).

²Ragupathi Soundararajan is with Xylem Water Solutions India Private Limited, Block#2, 1st Floor, Keval Corporate Park, Chhani, Vadodara, Gujarat- 391740, India (e-mail: Ragupathi.Soundararajan@xylem.com).

chamber to the upper chamber due to a possible Taylor instability, because Reynolds number for near the rotating shaft flow on the gap exceeds the critical Reynolds number for Taylor instability [6].

In case 2, the water domain of the lower chamber was excluded from the calculations. Instead, the outside air domain was included to make the calculations of heat losses of the upper chamber more precise. The fan which cools the motor as well as the seal chamber was considered in the model.

Heat due to the friction of shaft rotating at the upper chamber was modeled with additions of heat source on the upper chamber.

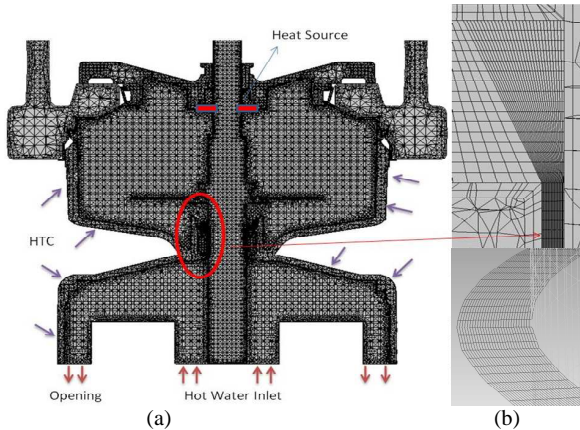

Fig. 3 (a) Case1 mesh distribution (b) mesh cut-section with boundary conditions resolution on the gap

TABLE I
BOUNDARY CONDITIONS CASE1

Case 1 without air domain	
Boundary Conditions	Value
Hot water mass flow inlet	3.14 kg/s
Hot water temperature	177 deg C
Ambient temperature	37 deg C
Seal heat source	2.5e+9 w/m^3
Shaft Speed	2900 rpm
External wall HTC	15 w/m^2-k
Outlet	Opening

TABLE II
BOUNDARY CONDITIONS CASE2

Case 2 with air domain without hot water domain	
Boundary Conditions	Value
Motor fan velocity inlet	9 m/s
Hot water temperature	177 deg C
Motor wall temperature	43.5 deg C
Ambient temperature	37 deg C
Seal heat source	2.5e+9 w/m^3
Shaft Speed	2900 rpm
Outlet	Opening

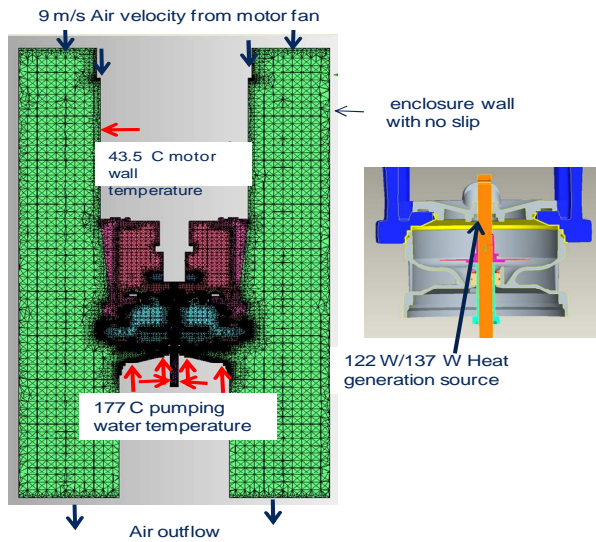

Fig. 4 (a) Case2 mesh distribution (b) Heat source

III. RESULTS

The calculations showed that heat due to flow convection between the lower and the upper chambers was negligibly small: it was around 0.01W. Therefore, the effect of Taylor instability was extremely low. It permitted to exclude the lower chamber water domain from further calculations. Fig. 5 (a) shows the temperature distribution at the gap area where water mixing is happening through the gap. Fig. 5 (b) temperature distribution of gap at dotted line location is indicated on Fig 5 (a).

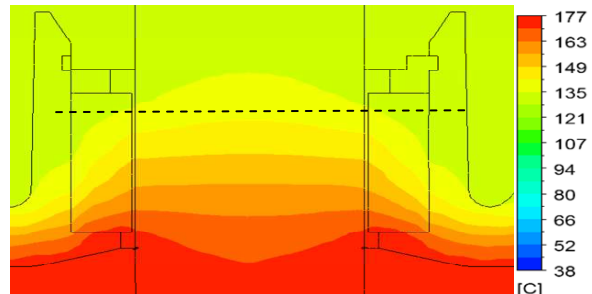

Fig. 5 (a) Temperature cut-section at seal chamber

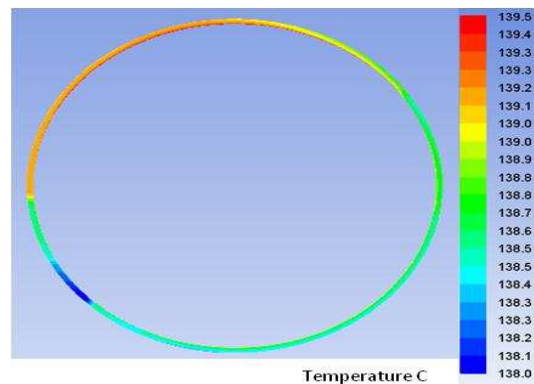

Fig. 5 (b) Temperature distributions at gap

The initial design was carried out with a single piece chamber where heat transferred to the upper chamber by conduction is shown in Fig 6. Temperature near the seal region, highlighted in Fig 6, is too high in comparison with the targeted value.

Fig 7 shows the results with the proposed design. Fan and surrounding air carry away the heat of the upper chamber which is generated by the seal and provides the suitable environment for the standard seal region. It is easy to see, by comparing the results on Fig 6 and Fig 7, that in case 2 temperature near the seal area is significantly lower than in case 1.

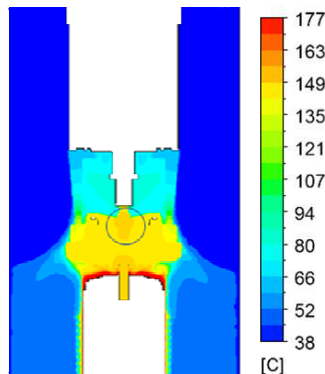

Fig. 6 Temperature distribution on initial design

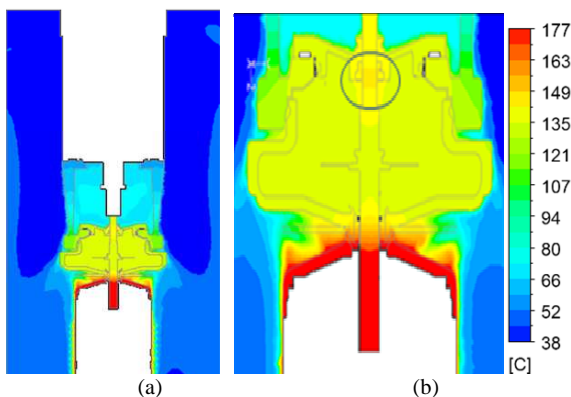

Fig. 7 (a) Temperature (b) Enlarged view distribution at proposed at seal chamber region design

The external wall of the upper chamber has the large range of HTC distribution, which is shown on Fig 8. Therefore, the calculations with constant value of HTC can lead to the wrong results. Therefore, model with conjugation heat transfer should be used.

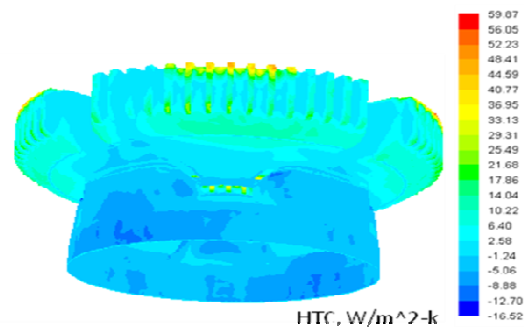

Fig. 8 Heat transfer coefficient at chamber external wall

The radiation heat losses from the walls were $\sim 14\text{W}$. Therefore, radiation plays a significant role ($\sim 10\%$ from total) in heat transfer in this particular case.

IV. DISCUSSIONS AND CONCLUSIONS

Heat addition on upper chamber due to seal rubbing surface has been varied based on different selection of seal. From the heat balance calculation, it is expected that every 12 watts of heat addition on seal rises the temperature to 10F in the nearby seal region. It is useful to select the range of seal that is suitable for this design.

The measurements of the water temperature near the seal area gave the same results, as the calculations. Therefore, this model approach can be recommended for future heat transfer calculations with complex geometries.

REFERENCES

- [1] Zhe Zhang, YanZhong Li, (2003) CFD simulation on inlet configuration of plate-fin heat exchangers, *Cryogenics*, Volume 43, Issue 12, December 2003, Pages 673-678
- [2] Masoud Rahimi Ayed, Reza Shabaniyan, Ammar Abdulaziz Alsairafi, (2009), Experimental and CFD studies on heat transfer and friction factor characteristics of a tube equipped with modified twisted tape inserts, *Chemical Engineering and Processing: Process Intensification*, Volume 48, Issue 3, March 2009, Pages 762-770
- [3] M. Angioletti, E. Nino, G. Ruocco, (2005), CFD turbulent modelling of jet impingement and its validation by particle image velocimetry and mass transfer measurements; *International Journal of Thermal Sciences* Volume 44, Issue 4, April 2005, Pages 349-356
- [4] Mikhail P. Strongin, (2010) CFD Modeling of Mixing Process in Pump for Two Liquids with Different Temperatures, ASME 2010 3rd Joint US-European Fluids Engineering Summer Meeting, Paper no. FEDSM-ICNMM2010-30969 pp. 793-795
- [5] ANSYS Fluent Theory Guide, Release 13.0, November 2010
- [6] L.D. Landau, E.M. Lifshitz (1987). *Fluid Mechanics*. Vol. 6 (2nd ed.). Butterworth-Heinemann. ISBN 978-0-080-33933-7.