

An Effective Islanding Detection and Classification Method Using Neuro-Phase Space Technique

Aziah Khamis and H. Shareef

Abstract—The purpose of planned islanding is to construct a power island during system disturbances which are commonly formed for maintenance purpose. However, in most of the cases island mode operation is not allowed. Therefore distributed generators (DGs) must sense the unplanned disconnection from the main grid. Passive technique is the most commonly used method for this purpose. However, it needs improvement in order to identify the islanding condition. In this paper an effective method for identification of islanding condition based on phase space and neural network techniques has been developed. The captured voltage waveforms at the coupling points of DGs are processed to extract the required features. For this purpose a method known as the phase space techniques is used. Based on extracted features, two neural network configuration namely radial basis function and probabilistic neural networks are trained to recognize the waveform class. According to the test result, the investigated technique can provide satisfactory identification of the islanding condition in the distribution system.

Keywords—Classification, Islanding detection, Neural network, Phase space.

I. INTRODUCTION

DISTRIBUTED generation (DG) is typically an additional resource located close to the load. These DGs are generally below a couple of MWs and it can be wind farms, micro hydro turbines, photovoltaics (PV) system and other small generators which are supplied with biomass or geothermal fuel. With the integration of DG resources, the use of multiple DGs in the distribution system becomes a common practice. DG integration has some advantages such as environmental benefits, improved reliability, increased efficiency, avoid transmission and distribution (T&D) capacity upgrades, improved power quality, and reduced T&D line losses [1]-[7]. However, one of the major drawbacks of the DG is unintentional islanding.

The unintentional islanding occurs when the DG is continued to power a part of the grid system even though powers from the utility do not exist, due to the fault at upstream or any other disturbance. Failure to trip unintentional islanded DG may lead to several problems in terms of power

quality, safety and operational problems [3], [8]-[9]. Furthermore, according to IEEE STD 1547-2001 and IEC 61727, unintentional islanding had to be cleared within two second from DG and utility connection with the formation of island [8], [10]-[11]. Therefore, various methods to detect the unintentional islanding conditions have been receiving great interest among many researchers.

Conventionally, these islanding techniques can be classified into two main groups, which are remote (communication) techniques and local (residence) techniques. Remote islanding detection techniques are based on communication between the utility and the DGs. These techniques have better reliability, and they are easy to implement. However, large investments are needed especially for small systems. Therefore, engineers utilized the local techniques to detect islanding condition. The local techniques are further categorized into two: passive techniques and active techniques. The passive detection method utilizes measured electrical quantities such as voltage, current and frequency. Meanwhile, in the active detection method, disturbances are injected into the network and the island is detected based on system responses to the injected disturbances. In passive islanding detection methods, computational intelligence is commonly used. This is preferred because more accurate online detection is needed to monitor the system condition. Besides, this technique usually has less complexity and high computational efficiency with good accuracy and reliability. Some existing techniques which combine signal processing and neural network are highlighted below.

Signal processing and neural network are widely used in power quality event classification and detection. These methods are also finding their application in islanding condition detection for DG protection in distribution networks. For instance, in [12] used discrete wavelet transform (DWT) integrated probabilistic neural network (PNN) to classify the power disturbances. It used multiresolution-analysis of DWT and Parseval's theorem to extract energy distribution features at different resolution levels. It then classifies the features using PNN. Other than that, PNN is incorporated with wavelet transform to find the location of the fault and its type [13]. Realizing the potential of these intelligent methods, Yin presented a combined method using Fast Fourier transforms (FFT) with artificial neural network (ANN) classifier for detecting islanding detection [14]. In this method, the output voltages of the inverter are sampled and the signal frequency domain is obtained by using FFT. However, the algorithm suitable for stationary waveforms and it can be implemented

Aziah Khamis is with the Department of Electrical, Electronic & Systems Engineering, Universiti Kebangsaan Malaysia (UKM), 43600 Bangi, Selangor, Malaysia, on leave from Department of industrial power, Universiti Teknikal Malaysia Melaka (UTeM), Hang Tuah Jaya, 76109 Durian Tunggal, Melaka, Malaysia. (phone: +603-89216590; e-mail: aziah@utem.edu.my).

H. Shareef is with the Department of Electrical, Electronic & Systems Engineering, Universiti Kebangsaan Malaysia (UKM), 43600 Bangi, Selangor, Malaysia (phone: +603-89216590; e-mail: shareef@eng.ukm.my).

using advanced digital signal processor. To avoid the problems of FFT, a robust approach for islanding detection is introduced based on the theory of wavelet and ANN [15]. In this method, the feature vector is extracted by utilizing DWT from the modal current signal seen at the DG terminal. These features are then trained using back propagation method.

Similar to the aforementioned signal processing methods like DWT, a new technique called phase space method is gaining its popularity in signal processing specially in the field of electrical engineering. Phase space method reconstructs a time series in a higher-dimensional space. The aim of this construction is to show its features more clearly [16]. As a result of its unique feature characteristics, starting in 2000, the phase space is utilized in power quality disturbance classification based on geometrical properties [17]. Afterwards, [18] utilized phase space to detect, locate and classify the disturbances of power system signals. It has been evaluated with numbers of test, which involve eight different types of disturbances under various conditions. This method is able to locate the occurrence of disturbance and accurately classifies all eight disturbances. Meanwhile, in [19] phase space is used in fault detection of distance relay. It is claimed that the speed of the phase space fault detection technique is only 4 ms and it is suitable for real-time implementation. However, this technique is not being applied in islanding condition yet.

Due to the clarity of features, high reliability, efficiency and speed, the phase space technique is proposed in this paper as the feature extraction method for detecting the islanding and non-islanding condition. Afterwards, the paper investigates the feasibility of using radial basis function (RBF) and probabilistic neural network (PNN) based classifier for differentiating the islanding event from others system disturbance events. The feature vectors, which are inputs to the classifier, were generated by processing the voltage signals containing the transients using the phase space method. The rest of the paper is organized as follows: section II includes the phase space theory. Meanwhile, in section III has classification methods that briefly explain two of the classifier method that being used, which is RBF and PNN, and section IV gave a system description. Section VI explains the feature extraction using phase space and section VII deal with the structure of the proposed neural network. The test result is presented in Section VII. Finally, the conclusion is given in section VIII.

II. PHASE SPACE THEORY

The aim of phase space is to analyze the time series in a higher-dimensional space called phase space. Mathematically, a phase space is a space, which all possible states of the system are presented. This phase state would respond to a unique point. It is convenient to use phase space to describe dynamic system. Each orthogonal coordinates of phase space would represent one of the instantaneous states of the system [16], [20]. Nonetheless, it is impractically to measure the entire variability of a dynamic system. Coincidentally, Taken

has proved in [21] that it can be reconstructed from a time series of a single component using the embedding theorem.

For this studied, as for a sinusoidal signal, the embedding of phase space can be defined by the general equation given as [18], [22]:

$$\begin{aligned} \mathbf{x}_k &= [A\sin(\omega k\Delta t + \phi) \quad A\sin(\omega(k+\tau)\Delta t + \phi) \quad A\sin(\omega(k+2\tau)\Delta t + \phi)] \\ &= [A\sin(\omega k\Delta t + \phi) \quad A\cos(\omega k\Delta t + \phi) \quad -A\sin(\omega k\Delta t + \phi)] \\ &= [x_{1k} \quad x_{2k} \quad x_{3k}] \end{aligned} \quad (1)$$

where, x_{1k} can represent as x ; x_{2k} can represent as y ; and x_{3k} can represent as z . Equation (1) shows the embedding signals to a phase space of $d_E=3$ with a delay of a quarter of its period that is $\tau=Ns/4$.

Actually, $x_{1k}^2 + x_{2k}^2 = A^2$, $x_{2k}^2 + x_{3k}^2 = A^2$ and $x_{1k} + x_{3k} = 0$, which shows that embedded signal is an ellipse. Using x , y and z to represent the coordinates of the phase space x_1, x_2, x_3 , respectively the embedded signal in the phase space can be defined by the following equations

$$\begin{cases} x + y = 0 \\ x^2 + y^2 = A^2 \end{cases} \quad \begin{cases} x + z = 0 \\ y^2 + z^2 = A^2 \end{cases} \quad (2)$$

The projection of embedded signal on the xy -plane and yz -plane is same, where the circle radius is the amplitude (A) and center is the origin of the plane.

By using (2), Euclidean norm E_x can be obtained as,

$$E_x = \sqrt{x^2 + y^2} \quad (3)$$

In this paper, the E_x would be utilized to extract special features for characterizing islanding and non-islanding events. The corresponding features are then used as inputs for the neural network.

III. ARTIFICIAL NEURAL NETWORK THEORY

A. Radial Basis Function

Radial basis functions (RBF) emerged as a variant of artificial neural network in late 80's. RBF is embedded into a two layer neural network, where each hidden unit implements a radial activation function. The network is characterized by set of input and set out output, where the middle of both input and output is a layer processing unit called hidden layer. Each input neuron corresponds to a component of an input vector x . The middle layer consists of n neurons and one bias neuron. Each input neuron is fully connected to middle layer neuron except the bias one. Each middle layer neuron computes a kernel function (activation function) which is usually the following Gaussian function [23]. More details on RBF can be found on [23]

$$y_i = \begin{cases} \exp\left(-\frac{\|x - c_i\|}{2\sigma_i^2}\right) & i = 1, 2, \dots, n \\ 1 & i = 0 (\text{bias neuron}) \end{cases} \quad (4)$$

where C_i and σ_i the center and the width of the i th neuron in the middle layer, respectively. $\|\cdot\|$ denotes the Euclidean distance. The weight vector between the input layer and the i th middle layer neuron corresponds to the center C_i in (4).

B. Probabilistic Neural Networks

A probabilistic neural network (PNN) is a neural network that is usually utilized in classification techniques. It is based on Bayesian classifier technique that is commonly used in classical pattern-recognition application [24]. PNNs contain four layers such as the input layer, the pattern layer, the summation layer and the output layer, where each layer has their own function in classifying the features [25].

The learning speed of PNN model is very fast, making it suitable for fault diagnosis and signal classification problem in real time. In addition, online adaptation to new patterns can be easily implemented by way of modifying its training database with new patterns and will able to categorize correctly.

IV. TEST SYSTEM DESCRIPTION

The system model is based on real system data from [26]-[27]. In this study, the power system simulation tool DigSilent® is used to simulate the system model. The test system model consists of a radial distribution system with two identical DG units, which is fed by 120 kV, 1000MVA source at 50 Hz frequency illustrated in Fig. 1. The DG units are placed within a distance of 30-km with a distribution line of π -sections. This DG unit is designed with 1200Vdc and controlled by a decoupled power control. The details of the studied system are given in Table I.

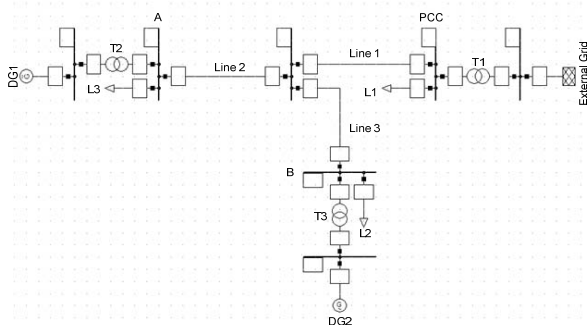

Fig. 1 Power distribution system with multiple DG interface

The voltage signals are retrieved at the target DG location for islanding and non-islanding conditions (others disturbances). The possible simulation scenarios studied are given as follows:

1. Normal Condition
2. Switching Capacitor at PCC point, near DG1 and near DG2.
3. Switching Load at PCC, near DG1 and near DG2
4. Single Line to ground fault at PCC, near DG1 and near DG2 (A-G, B-G, C-G)
5. Double Line to ground fault at PCC, near DG1 and near DG2 (AB-G, BC-G, CA-G)
6. Three phase fault at PCC, near DG1 and near DG2.
7. Single Line to ground fault at Line 1, Line 2 and Line 3 (A-G, B-G, C-G)
8. Double Line to ground fault at Line 1, Line 2 and Line 3 (AB-G, BC-G, CA-G)
9. Three phase fault at Line 1, Line 2 and Line 3.
10. Malfunction of circuit breaker at DG terminal (islanding)
11. Tripping of main circuit breaker and tripping of other DG apart from the target one (islanding)

TABLE I
SYSTEM MODEL DESCRIPTION

Parameter	Description
External Grid	Grid represented by 120KV source and 1000MVA
L1	Load with 15MW and 3MVar
L2 & L3	Load with 8MW and 3MVar
DG1 & DG2	1200Vdc
T1	Transformer 120/25 kV
T2&T3	Transformer 25/0.6 kV
Line 1	25kV with 10km length
Line 2 & Line 3	25kV with 20km length
PCC	Point Common Coupling
A & B	Point near by the respective DG (A is point near DG1; B is point near DG2)

V. FEATURE EXTRACTION

It is important to select suitable input features before implementing and trained in the neural network. The input of features of RBF and PNN is selected by extracting the three phase voltage signal using the phase space method. The purposed of feature extraction is to identify the specific signature of the voltage signal, which could differentiate between the islanding and any other event condition. Seventeen features are extracted from the data collected for training. This section described the input features accordingly as shown in Table II.

The features with mean value of E_x during the period of fault or after first transient period to the next transient period of disturbance is obtained from the following equation:

$$\text{Mean, } \overline{E_x} = \frac{\sum_{x=1}^n E_x}{n} \quad (5)$$

where n is number of the sample points. Meanwhile, features with standard deviation (SD) of E_x can be calculated as:

$$s = \left(\frac{1}{n} \sum_{i=1}^n (E_{x_i} - \overline{E_x})^2 \right)^{1/2} \quad (6)$$

where $\overline{E_x}$ is the mean of E_x and E_{x_i} is the number of elements in the individual value of E_x for $i=1,2,3,\dots,n$

TABLE II
SELECTED FEATURES

Features	Description	Features	Description
F1	Duration of Disturbance	F10	Min E_x during Disturbance DG1
F2	Mean E_x during Disturbance DG1	F11	Min E_x during Disturbance DG2
F3	Mean E_x during Disturbance DG2	F12	Min Steady State during Disturbance DG1
F4	Mean Steady State during Disturbance DG1	F13	Min Steady State during Disturbance DG2
F5	Mean Steady State during Disturbance DG2	F14	SD E_x during Disturbance DG1
F6	Max E_x during Disturbance DG1	F15	SD E_x during Disturbance DG2
F7	Max E_x during Disturbance DG2	F16	SD Steady State during Disturbance DG1
F8	Max Steady State during Disturbance DG1	F17	SD Steady State during Disturbance DG2
F9	Max Steady State during Disturbance DG2		

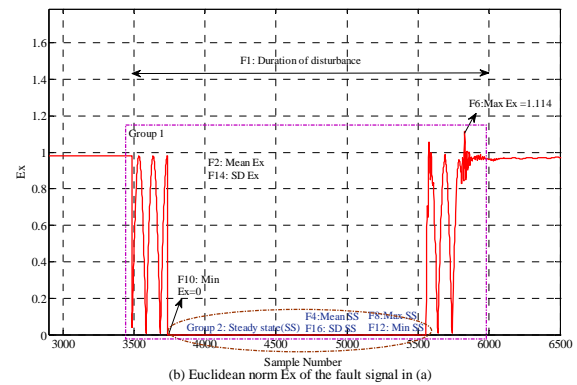
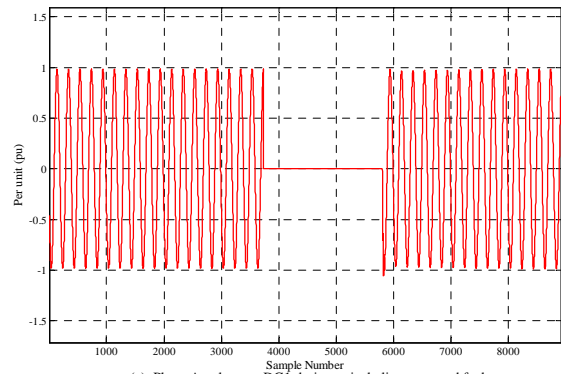

Fig. 2 Phase space feature extraction

VI. STRUCTURE OF PURPOSED NEURAL NETWORK

In this study, three networks are used in which each of the networks represent phase A, B and C respectively as shown in Fig. 3. The extracted seventeen features are the inputs to each neural network model which is developed in MATLAB® software.

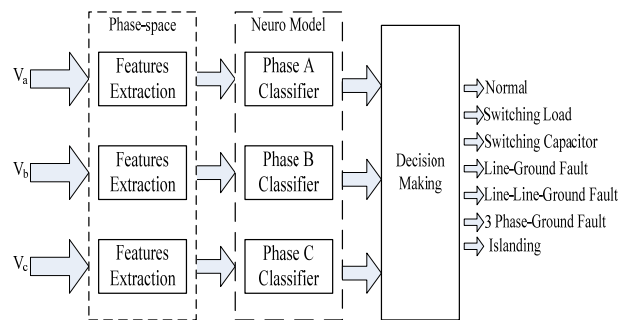

Fig. 3 Structure of classification technique

Fig. 2 shows an example of a single phase fault at phase A measured at DG1 terminal and corresponding phase space representation. The data in Fig. 2 (b), are grouped into two. Group one data is used to extract the features of total event such as the duration of event, while group two data represents steady state period during disturbance where transients are minimal. Fig. 2 also exhibit some of the features such as mean, maximum, minimum and SD of E_x values that are extracted.

Fig. 4 summarizes the description of input and outputs of neural network used for training and testing islanding detection scheme.

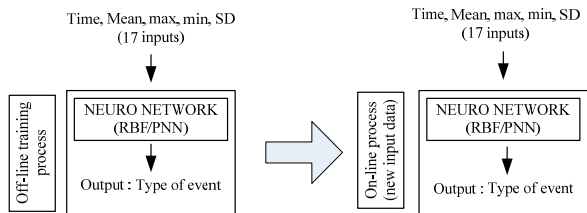

Fig. 4 Description of inputs and outputs of the training and simulation data for neural network for one phase

A data set consisting of 268 samples are used for each of the phases, which divided into training, validation and testing. In these cases, 134 samples (60%) of data are used for the training and 67 samples (20%) of data are applied for validation and testing. Table III shows the number of samples for training, validation and testing data.

TABLE III
NUMBER OF SAMPLES FOR TRAINING, VALIDATION AND TESTING

Data types	Number of sample data, h
Training	134
Validation	67
Testing	67

For the RBF and PNN implementation, the same 134 training data sets consisting of seven particular events are generated, while data sets with 67 different samples have been used for testing purposes. TABLE IV shows the target value based on the type of event class. The output of both RBF and PNN are then compared with the actual target data.

The overall procedure of islanding and non-islanding detection is shown in Fig. 5.

TABLE IV
SETTING OF EVENT TYPE

Event Type	Target
Normal Condition	1
Line to Ground Fault	2
Line to Line to Ground Fault	3
Three phase to Ground Fault	4
Load Switching	5
Capacitor Switching	6
Islanding	7

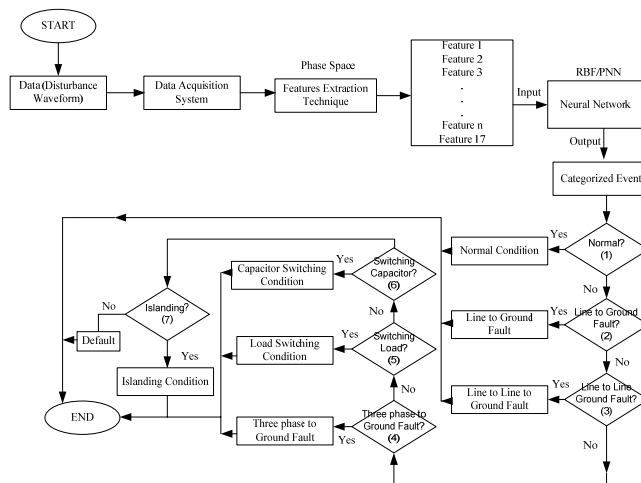

Fig. 5 Proposed islanding and non-islanding (other disturbance) scheme

VII. TEST RESULT

A. RBF Performance

The performance of islanding classification and detection using the phase space and RBF classifier was evaluated using testing data after being trained by the RBF model. This test data contains non-islanding and islanding events. Here, some of the sample of RBF testing results is shown as in Table V in which the yellow cells in the table denote the misclassification of events. As shown in the table, the RBF results are compared with actual or target value. The RBF outputs are not in crisp value in the range of 1 to 7. Hence, the RBF numbers have to round first before it is compared with the actual target value. From the Table V, note that the SL denotes as load switching, SC is capacitor switching, LG denotes as line to ground fault, LLG is line to line to ground fault, LLLG is three phase to ground fault and I is islanding condition. From the observation, it shows that most of the misclassifications are recorded as fault of types and also the islanding events.

B. PNN Performance

Table VI shows several samples of PNN testing result in which the yellow cells in the table denote the misclassification of events. However, the PNN was testing the 67 sets of test data. From the Table VI, note that the SL denotes as load switching, SC is capacitor switching, LG denotes as line to ground fault, LLG is line to line to ground fault, LLLG is three phase to ground fault and I is islanding condition. Table VI shows that most of the misclassification is recorded in load and capacitor switching cases. Comparing the testing result of PNN and RBF, it can be concluded that the performance of PNN is better than RBF in detecting and classifying islanding condition.

The comparison of neural network classification accuracy for islanding and non-islanding events of the phase respectively is depicted in Table VII. It is observed that the overall accuracies of non-islanding condition in the case of RBF are 88.718%, while 94.872% for the PNN cases.

However, from the observation, the RBF cannot detect the islanding condition at all. Meanwhile, the average accuracies of islanding in PNN are most perfect, which is 100%. The performance comparison for computation time is represented

in TABLE VIII. It is shown that learning epochs, training time and testing time of PNN is much lower than RBF. Thus, the PNN-based technique is more accurate and faster compared to other existing techniques for islanding detection.

TABLE V
RBF TESTING RESULT

Case	Actual	RBF-A	Round	Case	Actual	RBF-B	Round	Case	Actual	RBF-C	Round
SL	5	4.9081	5	SL	5	5.1344	5	SL	5	4.9521	5
SC	6	6.0533	6	SC	6	6.1178	6	SC	6	6.2794	6
SC	6	5.9072	6	SC	6	5.3348	5	SC	6	6.1878	6
LG	2	2.0462	2	LG	2	2.2024	2	LG	2	2.5955	3
LLG	3	3.0384	3	LLG	3	2.846	3	LLG	3	2.7022	3
LG	2	2.1744	2	LG	2	3.1022	3	LG	2	0.541	1
LLG	3	4.0237	4	LLG	3	2.8829	3	LLG	3	-20.221	-20
LG	2	1.9905	2	LG	2	2.1702	2	LG	2	1.8132	2
LLG	4	2.5498	3	LLG	4	4.2646	4	LLG	4	3.129	3
LG	2	1.9543	2	LG	2	1.9916	2	LG	2	1.8237	2
LLG	3	2.0169	2	LLG	3	3.2049	3	LLG	3	-31.127	-31
LLG	3	3.2548	3	LLG	3	3.0152	3	LLG	3	2.3049	2
LLG	3	2.7168	3	LLG	3	3.0336	3	LLG	3	3.867	4
LLG	4	4.0821	4	LLG	4	3.9572	4	LLG	4	4.0517	4
LLG	4	4.0354	4	LLG	4	3.9791	4	LLG	4	3.0662	3
LG	2	1.9656	2	LG	2	2.3403	2	LG	2	2.4988	2
LG	2	1.7735	2	LG	2	2.5248	3	LG	2	1.712	2
LG	2	1.9192	2	LG	2	1.8725	2	LG	2	2.0795	2
LG	2	1.8088	2	LG	2	1.8466	2	LG	2	2.0808	2
LG	2	2.4213	2	LG	2	2.6713	3	LG	2	2.1685	2
LG	2	2.0238	2	LG	2	2.1249	2	LG	2	2.044	2
LLG	3	2.721	3	LLG	3	2.9909	3	LLG	3	4.2374	4
LLG	3	2.9528	3	LLG	3	2.9967	3	LLG	3	3.1164	3
LLG	4	3.9019	4	LLG	4	3.2527	3	LLG	4	3.1592	3
LLG	4	3.878	4	LLG	4	4.2321	4	LLG	4	3.882	4
LG	2	1.9165	2	LG	2	2.0909	2	LG	2	1.2157	1
LG	2	2.5805	3	LG	2	2.1808	2	LG	2	1.6186	2
LG	2	2.1589	2	LG	2	2.0236	2	LG	2	2.2894	2
LG	2	2.2079	2	LG	2	1.8411	2	LG	2	0.9667	1
LLG	3	2.8944	3	LLG	3	2.6315	3	LLG	3	2.9744	3
LLG	4	4.0597	4	LLG	4	3.4842	3	LLG	4	4.0495	4
LLG	4	3.8481	4	LLG	4	3.8853	4	LLG	4	3.8639	4
I	7	12.3201	12	I	7	12.323	12	I	7	10.616	11
I	7	-0.2188	0	I	7	2.4451	2	I	7	4.8138	5

TABLE VII
COMPARISON OF NEURAL NETWORK CLASSIFICATION ACCURACY

Events	Classification accuracy (%)	
	RBF	PNN
	Phase A	
Islanding	0	100
Non-Islanding	96.923	96.923
	Phase B	
Islanding	0	100
Non-Islanding	90.769	93.846
	Phase C	
Islanding	0	100
Non-Islanding	78.461	93.846
	Total Accuracy	
Islanding	0	100
Non-Islanding	88.718	94.872

TABLE VIII
PERFORMANCE COMPARISON BETWEEN NEURAL NETWORKS

Parameter	RBF	PNN
Learning Epochs	125	1
Training CPU Time (Sec)	0.123759	0.115925
Testing CPU Time (Sec)	0.722817	0.203702

VIII. CONCLUSION

An effective method for the islanding and non-islanding detection using neuro-phase space technique is presented in this paper. The method uses three classifiers for each phase and takes a measurement of voltage signals as the inputs. The phase space techniques were utilized for extracting all the special features for classifying the transients. The features extracted from phase space technique are very simple and effective. Two types of classifiers namely RBF and PNN were investigated. The results show that the PNN classifier performs better than RBF classifier. The PNN algorithm takes less computation and it efficiently classified the islanding and non-islanding events.

ACKNOWLEDGMENT

The authors wish to acknowledge the Ministry of Higher Education, Malaysia and Universiti Teknikal Malaysia Melaka for the financial funding of this project, and Universiti Kebangsaan Malaysia for providing infrastructure and moral support for the research work.

REFERENCES

- [1] M. Moradzadeh, M. Rajabzadeh, and S. M. T. Bathaee, "A novel hybrid islanding detection method for distributed generations," in *Proc. 3rd Int. Conf. Electric Utility Deregulation and Restructuring and Power Technologies*, Nanjing, China, 2008, pp. 2290-2295.
- [2] R. Shariatinasab, "New islanding detection technique for DG using discrete wavelet transform," in *Proc. IEEE Int. Conf. Power and Energy*, Kuala Lumpur, Malaysia, 2010, pp. 294-299.
- [3] P. Mahat, and B. Bak-Jensen, "Review of islanding detection methods for distributed generation," in *Proc. 3rd Int. Conf. Electric Utility Deregulation and Restructuring and Power Technologies*, Nanjing, China, 2008, pp. 2743-2748.
- [4] I. J. Balaguer-álvarez, and E. I. Ortiz-rivera, "Survey of distributed generation islanding detection methods," *IEEE Latin America Trans.*, vol. 8, no 5, pp. 565-570, September 2010.
- [5] P. K. Ray, S. R. Mohanty, and N. Kishor, "Disturbance detection in grid-connected distributed generation system using wavelet and s-transform," *Electric Power Systems Research*, vol. 81, no 3, pp. 805-819, March 2011.
- [6] P. K. Ray, S. R. Mohanty, N. Kishor, and H. C. Dubey, "Islanding and coherency detection in distributed generation based hybrid power system," in *Proc. Annual IEEE India Conf.*, Kolkata, India, 2010, pp. 1-4.
- [7] A. S. Aljankawey, W. G. Morsi, L. Chang, and C. P. Diduch, "Passive method-based islanding detection of renewable-based distributed generation: The issues," in *Proc. IEEE Electrical Power and Energy Conf.*, Canada, 2010, pp. 1-8.
- [8] P. Mahat, Z. Chen, and B. Bak-jensen, "Review on islanding operation of distribution system with distributed generation," in *Proc. Power and Energy Society General Meeting*, Michigan, USA, 2011, pp. 1-8.
- [9] Y. Fayyad, "Neuro-wavelet based islanding detection technique," in *Proc. IEEE Electrical Power and Energy Conf.*, Selangor, Malaysia, 2010, pp. 1-6.
- [10] P. Mahat, Z. Chen, and B. Bak-jensen, "A hybrid islanding detection technique using average rate of voltage change and real power shift," *IEEE Trans. Power Delivery*, vol. 24, pp. 764-771, April 2009.
- [11] V. Menon, and M. H. Nehrir, "A hybrid islanding detection technique using voltage unbalance and frequency set point," *IEEE Trans. Power Systems*, vol. 22, pp. 442-448, February 2007.
- [12] Z. Gaing, "Wavelet-based neural network for power disturbance recognition and classification," *IEEE Trans. Power Delivery*, vol. 19, no 4, pp. 1560-1568, October 2004.
- [13] M. F. Othman, and H. A. Amari, "Online fault detection for power system using wavelet and PNN," in *Proc. 2nd IEEE Int. Conf. Power and Energy (PECon)*, Johor Bahru, Malaysia, 2008, pp. 1644-1648.
- [14] G. Yin, "A distributed generation islanding detection method based on artificial immune system," in *Proc. IEEE-PES Transmission and Distribution Conf. & Exposition: Asia and Pacific*, Dalian, China, 2005, pp. 1-4.
- [15] M. Elnozahy, E. El-saadany, and M. Salama, "A robust wavelet-ANN based technique for islanding detection," in *Proc. Power and Energy Society General Meeting*, San Diego, CA, pp. 1-8, 2011.
- [16] T. Sauer, J. Yorke, and M. Casdagli, "Embedology," *J. Statistic Phys.*, vol. 65, no3, pp 579-616, November 1991.
- [17] L. I. Egufluz, M. Mafiana, and J. C. Lavandero, "Disturbance classification based on the geometrical properties of signal phase-space representation," in *Proc. Int. Conf. Power System Technology*, Perth, WA, Vol. 3, pp 1601-1604, 2000.
- [18] T. Y. Ji, Q. H. Wu, L. Jiang, and W. H. Tang, "Disturbance detection, location and classification in the phase space," *IET Generation, Transmission and Distribution*, vol. 5, pp 257-265, February 2011.
- [19] S. R. Samantaray, "Phase-space-based fault detection in distance relaying," *IEEE Trans. Power Delivery*, vol. 26, no.1, pp 33-41, January 2011.
- [20] G. L. Baker, and J. P. Gollub, "Chaotic dynamics: An introduction," Cambridge University Press, 1996.
- [21] F. Takens, "Detecting strange attractors in turbulence," *Dynamical systems and turbulence*, Warwick, pp. 366-381, 1981.
- [22] T. Y. Ji, Q. H. Wu, and Y. S. Xue, "Disturbance location and classification in the phase space," in *Proc. IEEE-PES General Meeting*, Minneapolis, MN, pp 1-8, 2010.
- [23] Y. S. Hwang, and S. Y. Bang, "An efficient method to construct a radial basis function neural network classifier," *Neural networks*, vol 10, no 8, pp 1495-1503, November, 1997.
- [24] E. Parzen, "On estimation of a probability density function and mode," in *Statistics, Annals of Mathematical*, vol. 33, no 3, pp. 1065-1076, September 1962.
- [25] Goh A.T, "Probabilistic neural network for evaluating seismic liquefaction potential," *Canadian Geotechnical Journal*, vol. 39, no 1, pp. 219-232, February 2002.
- [26] M. B. Reynen, A. H. Osman, and O. P. Malik, "Using gold sequences to improve the performance of correlation based islanding detection," *Electric Power Systems Research*, vol. 80, no 6, pp. 733-738, June 2010.
- [27] Y. Fayyad, "Neuro-wavelet based islanding detection technique," in *Proc. IEEE Electrical Power & Energy Conf.*, Halifax, NS, 2010, pp. 1-6.

Aziah Khamis received his BSc with honours from Universiti Putra Malaysia (UPM), Malaysia, MSc degree from Newcastle Universiti, UK in 2006 and 2008 respectively. She is a lecturer in Universiti Teknikal Malaysia Melaka (UTeM). Her current research interests are power system distribution and renewable energy. She is currently on study leave and pursues the Ph.D in Faculty of Electrical and Built Environment, Universiti Kebangsaan Malaysia

(UKM), Selangor. She can be contacted at aziah@utem.edu.my or +603-89216590.

Hussain Shareef received his BSc with honours from IIT, Bangladesh, MS degree from METU, Turkey, and PhD degree from UTM, Malaysia, in 1999, 2002 and 2007, respectively. His current research interests are power system deregulation, power quality and power system distribution automation. He is currently an associate professor at Faculty of Electrical and Built Environment, Universiti Kebangsaan Malaysia. He can be contacted at shareef@eng.ukm.my or +603-89216590.