

Power Electronic Solution for High Energetic Efficiency of a Thermo Plant

Aziza Benaboud, and Alfred Rufer

Abstract—In this paper the authors propose a flexible electronic solution, to improve the energetic efficiency of a thermo plant. This is achieved by replacing the mechanical gear box, placed traditionally between a gas turbine and a synchronous generator, by a power electronic converter. After reminding problematic of gear boxes and interest of a proposed electronic solution in high power plants, the authors describe a new control strategy for an indirect frequency converter, which is characterized by its high efficiency due to the use of SWM: Square Wave Modulation. The main advantage of this mode is the quasi absence of switching losses. A control method is also proposed to resolve some problems incurred by using square wave modulation, in particular to reduce the harmonics distortion of the output inverter voltage and current. Simulation examples as well as experimental results are included.

Keywords—Angle shift, high efficiency, indirect converter, gas turbine, NPC three level converter, square wave modulation SWM, switching angle.

I. INTRODUCTION

MANY electric power generators use gas turbines as power sources. Typically they are connected to the turbines through a mechanical gearbox in order to adapt their synchronous speed to the optimal rotation speed of the turbine, which is very often much higher than the synchronous speed.

A. Mechanical Gear Boxes

These last years, the mechanical gear boxes know a great progress in high power field. As an example; a standard type of reducers: SG (Standard GEAR links), present 98.5% of efficiency and are intended to deliver powers around 140 MW [1], [2].

However, in spite of this progress and of the convincing economic reasons, the mechanical gear boxes present major disadvantages:

- Lubrification oil increases the fire risk, it requires more protection.
- Heavy weight and unacceptable noise level.
- And due to direct network connection, the generator speed cannot be variable: it is imposed by the network and is constant. (See Fig. 1). Its elimination is then wished.

Aziza Benaboud received the PhD in electrical engineering from EPFL: Swiss Federal Institute of Technology, Lausanne in 2007. In 2009 she became a professor at ERN: Ecole Royale Navale, Casablanca, Morocco. Her actual research activities focus on power electronics and applications. (e-mail: aziza.benaboud@a3.epfl.ch).

Alfred Rufer is a full Professor and Head of the industrial Electronics Laboratory, EPFL. His actual research activities focus on power converters, where several solutions and applications of multilevel converters. (e-mail: Alfred.rufer@epfl.ch).

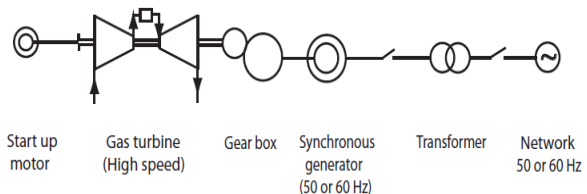

Fig. 1 Schematic of the electrical power generation system using gear box

B. Static Frequency Converter

To overcome this problem, many authors propose to replace the mechanical gearbox by a flexible electronic solution which offers the ability to operate with very high power, increases turbine efficiency by using variable speed. Fig. 2 proposes one schematic of the electrical power generation system using frequency converter. As shown in this figure the static converter can be used also to start the synchronous motor and the gas turbine [3]. Electronic solution presents then reduction in equipment and noise.

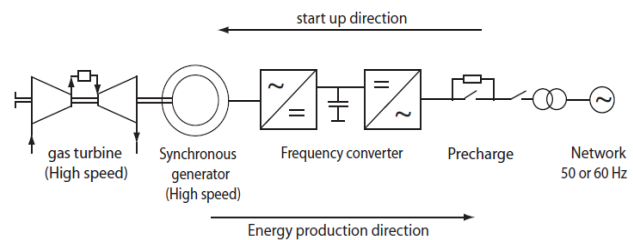

Fig. 2 Schematic of the electrical power generation system using frequency converter

The idea to replace the mechanical reducers by static converters existed for a long time because of the availability of the power electronic components and great flexibility of speed. There are two main groups of frequency converters:

The direct converters, that transform a given input electric power at frequency f_g directly into another power at frequency f_n . Typical examples are the cycloconverter as well as the matrix converter [4], [5], [6], [7]. Problems affect one or both types of direct converter: extra forced commutation at synchronous speed and poor quality converter currents [8], [9]. Moreover, cyclo-converters suffer from a limitation of the maximum output frequency to values smaller than half the mains frequency.

The indirect converters are characterized by a double frequency conversion AC to DC transformation followed by the DC to AC one. The intermediary circuit brings the advantage of decoupling of harmonics currents as well as of decoupling of reactive power between the generator and the

network. This type of converter is not common in high power application, because of very high switching losses due to the high frequency of the PWM technique normally used for its control [10], [11].

C. Proposed Control Strategy

In this contribution the authors propose a new control strategy for the three level Neutral Point Clamped converters, characterized by its high efficiency due to the use of square-wave modulation. The main advantage of this mode is the quasi absence of switching losses. In this mode, only the frequency can be varied between the input and the output voltage, but their magnitudes are not freely controllable. The produced active and reactive power can be controlled by the generator excitation as well as both the angle shift between the generator and rectifier voltages, and between the inverter and network voltages. A control method is also proposed to resolve some problems incurred by using square wave Modulation, in particular to reduce the harmonics distortion of the output inverter voltage and current. This can be achieved by selecting the switching angle in three level converter.

This paper is organized as follows: the principle of three level NPC inverter in SWM is introduced in section II, Power Flow Control is described in section III, and section IV, shows simulation and verification results. Finally section V concludes the paper.

II. THREE LEVEL NPC INVERTER IN SWM

Because of the limited blocking voltage value of the power semiconductors, the traditional two levels inverters cannot any more to be used. Indeed, in two levels inverter the supported voltage by a switch is the maximum voltage which can be appeared at the borders of the capacitors in the input of the inverter.

Unfortunately, until now this voltage value remains lower than a few kV. However, in high power area, the voltage used is much larger than the acceptable voltage by the semiconductors. With the NPC topology, three or multilevel converters allow to spread the output voltage on three or more levels and thus increase it above the voltage limits of classical semiconductors.

The earliest development of this technology dates to the late 1970s, where the diode clamped concept was introduced [12]. This evolved into the 3L-NPC known today [13], [14] and later became the first multilevel converter that made it into industrial application [15]. This topology features many outstanding advantages such as:

- a superior harmonic performance and doubled output voltage range compared to the two-level VSC.
- a high efficiency due to the quasi absence of switching losses offered by using SWM.

A. Superior Harmonic Performance

Fig. 3 shows the schematic diagram of three level three phases NPC inverter. In this figure, the DC side of three level inverter may be connected to the midpoint N via diodes to provide the third level for the output waveform [16].

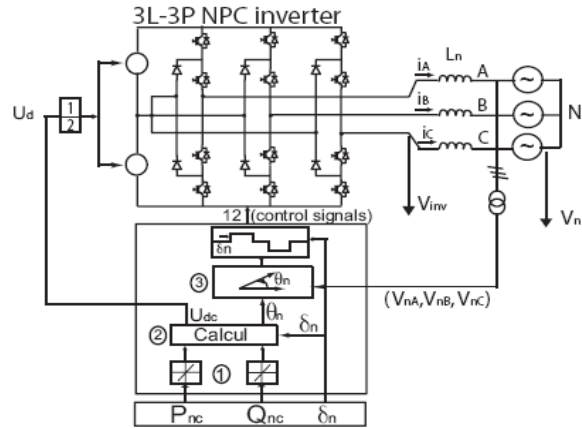

Fig. 3 Schematic diagram of 3L3P NPC

An output-voltage's waveform of a three-level converter operated in square-wave mode (SWM) is shown in Fig. 4. In this figure, δ_n represents a selected switching angle, which depends on the harmonics component according to (1) [17].

$$v \hat{U} = \frac{1}{\pi} \int_{-\pi}^{\pi} V_{AO} \sin(\omega t) d\omega t = \frac{4}{\pi} U_d \cos(\nu \delta_n) \quad (1)$$

The advantage of this method with SWM is that the specific harmonics can be cancelled simply by selecting the switching angle δ_n .

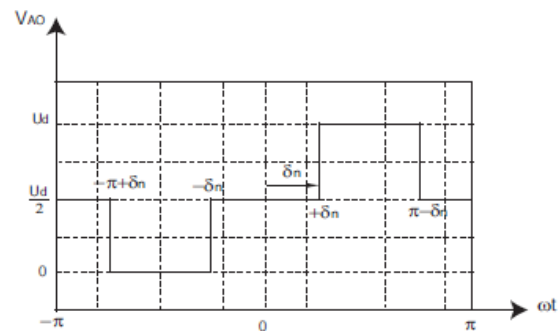

Fig. 4 Output-voltage's waveform of a three-level converter operated in SWM

Two important criteria must be taken into consideration when selecting the switching angle: fundamental voltage evolution and harmonic distortion (THD) of the output voltage. To illustrate this point, Fig. 5 presents in function of the switching angle, the ratio between the fundamental wave ${}^1\hat{U}$ and the DC voltage U_d given by (2). The THD of the output voltage according to (3) is also represented.

$$\frac{{}^1\hat{U}}{U_d} = \frac{2}{\pi} \cos \delta_n \quad (2)$$

$$\text{THD} = \frac{100}{\cos \delta_n} \sqrt{\sum_{v=5}^{\infty} \left(\frac{\cos(\nu \delta_n)}{\nu} \right)^2} \% \quad (3)$$

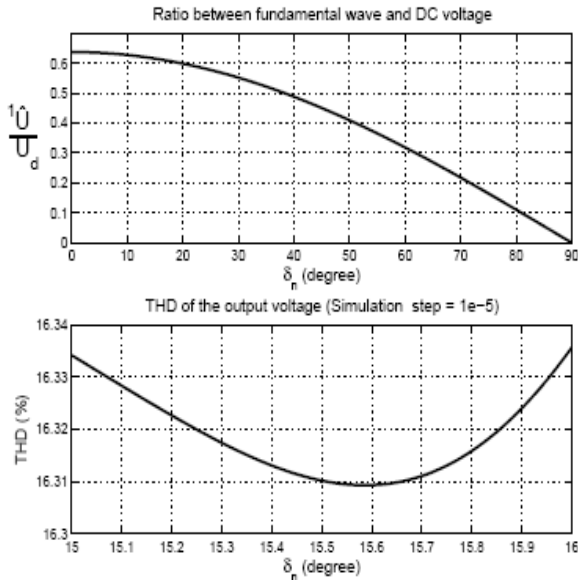

Fig. 5 The fundamental and the THD of the output voltage as a function of the switching angle δ_n

The curve in Fig. 5 shows that the ratio in (2) hardly changes, as a function of δ_n , in the range between 0° and 20° . In this range the output voltage's THD presents a minimum value, exactly when $\delta_n = 15.58^\circ$. The switching angle δ_n can also be optimized to eliminate some harmonics. For example, the 5th harmonic disappears when $\delta_n = 18^\circ$. By choosing the switching angle, the minimum of harmonics can be obtained ($\delta_n = 15.58^\circ \Rightarrow \text{TDH} = 16.31\%$). The traditional two level converter has more harmonic contents, which corresponds to ($\delta_n = 0^\circ \Rightarrow \text{TDH} = 31\%$). The advantage of this method with SWM is that the lower harmonics are reduced or eliminated without increasing the higher-order harmonics, contrary to what occurs in many PWM techniques. The disadvantage is that the fundamental output voltage is not freely controllable; it must be controlled by varying the DC link voltage. This point will be described in section III.

B. High Energetic Efficiency

In order to have an estimation of the converter efficiency, the model in Fig. 3 has been simulated using the following characteristics: $V_n=3\text{kV}$ is the network voltage. $I_n=1.5\text{kA}$ is the line current. $L_n = 1.3\text{mH}$ is the inductance. $S_n = 3/2 V_n I_n = 6.75\text{MVA}$ is the apparent power. $U_d = 5\text{kV}$ is the DC voltage at the input of the inverter. The semiconductors used in this model are: IGBT (5SNR20H2500) [18], they are driven first by using Pulse-Width Modulation and then in Square Wave Modulation. To make a comparison, Fig. 6 and 7 plot our results: the active and reactive powers are represented, together with total losses calculated using two solutions. In comparison with a maximal power (6.75 MW), the total losses in 3L3P NPC converter with PWM control, represent 9.7% which means approximately 90% efficiency (see Fig. 6). However in 3L3P NPC converter with SWM, the total losses represent only 0.2%, which means approximately 99.79%

efficiency. This high efficiency is achieved by the use of Square Wave Modulation which yields a quasi-absence of switching losses.

It is important to notice that for a complete back to back frequency converter, the produced power is affected twice by this efficiency value, i.e. 99.58%. [16]

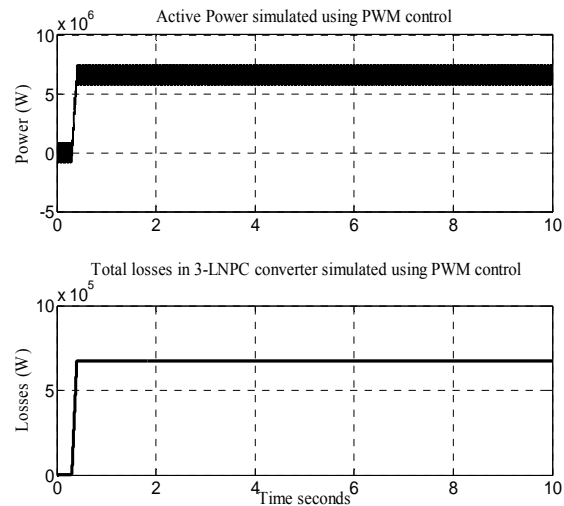

Fig. 6 Simulation results using PWM control

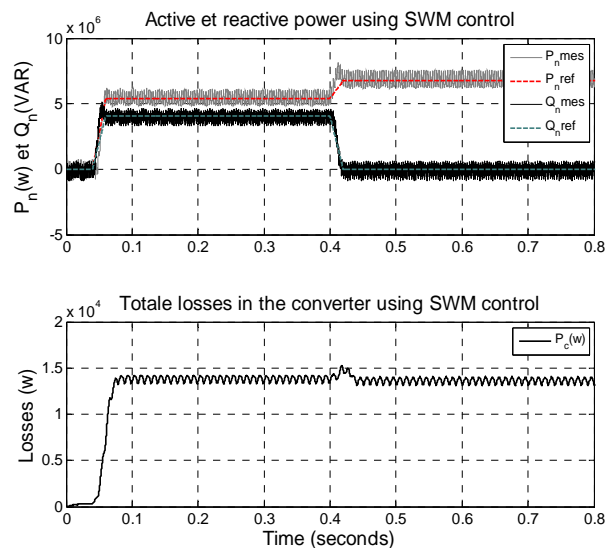

Fig. 7 Simulation results using SWM control

For high power applications, high voltage IGBTs are needed. To achieve the required output voltages, the use of three level technology with the available 2.5 kV and 2 kA devices [16], is not sufficient, so an internal series connection is necessary. In addition, to fulfill the demands of high power applications, it is necessary to use several leg modules in parallel [19]. This solution allows the output voltage and current to increase above the semiconductors limits, so that it can be used for high power applications.

III. POWER FLOW CONTROL

The present section describes a proposed control strategy preferably for a three level converter with neutral point Clamped (NPC) topology. Fig. 7 illustrates the schematic diagram of such a frequency converter used as an interface between a fast running synchronous generator, driven by a gas turbine and the network, in this application, the converter can be designated as a “frequency only converter”, due to the fixed ratio between the input and output voltage magnitude. Voltage adaptation, which is used for the power flow control through the network, can be achieved by changing the generator’s excitation. Both input and output converters are controlled in the same manner.

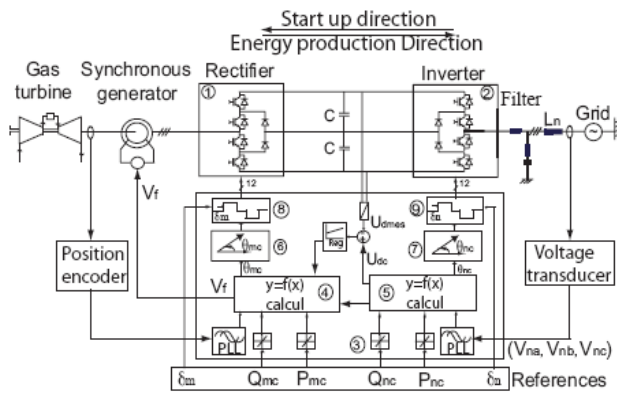

Fig. 8 Schematic diagram of the frequency converter used as an interface between a fast running synchronous generators and the grid

A. Line Side Properties

To simplify, and as shown in Fig. 3, the generator and its rectifier will be replaced with an adjustable DC voltage source at the input of the inverter.

Starting from the active and reactive powers references, the system runs initially in no load operation, with active and reactive powers equal to zero (Fig. 8-a). Both inverter and network voltages have the same phase where the amplitude is equal to nominal. Therefore the line current is very small (Fig. 13).

In the first transition at ($t = 0.4$ s), the network active and reactive powers are ramped to $P_{ref} = S_n \times \cos \varphi$ and to $Q_{ref} = S_n \times \sin \varphi$ respectively. Consequently, the angle shift and the DC voltage change from (θ_{n0}, U_{d0}) to (θ_{nc}, U_{dc}) (Fig. 8-b). Their values depend on the active and reactive power-references according to (4).

In the second transition, at ($t = 10$ s), the reactive power ramps down to zero, as shown in Fig. 13. Consequently, the angle shift and the DC voltage must change from (θ_{nc}, U_{dc}) to (θ_{nc}, U_{dc}) . Then the reactive power can be compensated and the system can be operated using a unity power factor (Fig. 13).

On the other hand, as depicted in (Fig. 13), the transition of the active and reactive power can be done in small and well

defined period, without generating the continuous component in the line or machine current [20], [21].

$$\left\{ \begin{array}{l} \theta_{nc} = \arctan \left(\frac{P_{nc}}{\frac{3}{2} \frac{V_n^2}{X_n} - Q_{nc}} \right) \\ U_{dc} = \frac{\pi}{2 \cos \delta_n} \sqrt{\left(V_n - \frac{2}{3} \frac{X_n}{V_n} Q_{nc} \right)^2 + \left(\frac{2}{3} \frac{X_n}{V_n} P_{nc} \right)^2} \end{array} \right. \quad (4)$$

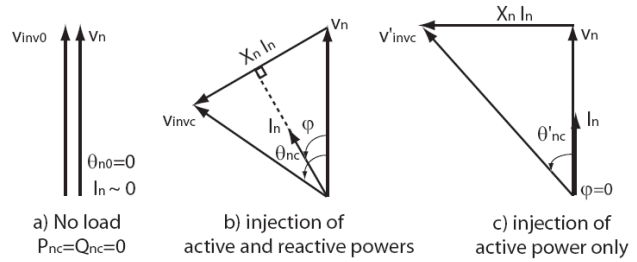

Fig. 9 Diagrams of voltage and current line side

B. Machine Side Properties

In this section the authors present some converter’s properties, in comparison with diodes rectifier circuit presented in Fig. 10, the proposed converter allows to improve machine current and voltage quality.

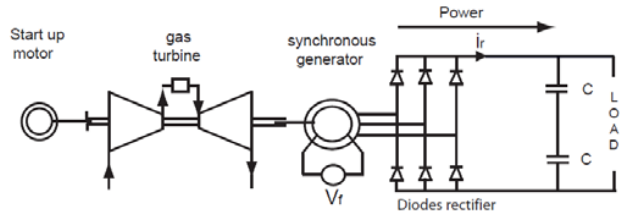

Fig. 10 Diode rectifier circuit connected to the synchronous machine

In spite of its performances as: a natural switching of diodes and its easy installation, the diode rectifier circuit does not allow the operation of the machine with low voltage and the start up motor is necessary.

Fig. 11 shows the proposed converter, as described in this figure, the IGBT rectifier circuit can be used also to start the synchronous motor and the gas turbine. Its control must be in Pulse Width Modulation PWM.

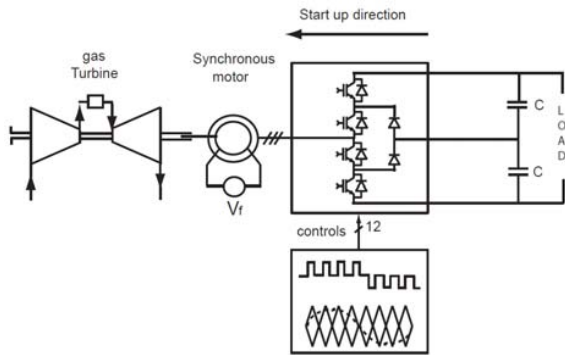

Fig. 11 IGBT rectifier circuit connected to the synchronous machine

However PWM techniques present high switching losses, for this reason, once turbine's start up process is achieved, the control with PWM of machine side converter is switched to SWM. To avoid current spikes, a good timing transition between PWM and SWM must be detected. (see Fig. 13).

In addition, the proposed machine side converter is controlled in the same manner as the line side converter, it presents then a high efficiency due to the use of SWM control, a high power factor and allows to improve machine current and voltage quality (see section II).

IV. SIMULATION AND PRACTICAL VERIFICATION RESULTS

In order to validate the proposed control strategy, the system depicted in Fig. 8, has been simulated in PLECS [22] using the following characteristics: $V_n = 1\text{pu}$ is the network voltage. $X_n = 1.2\text{ pu}$: inductance between inverter and network. $S_n = 1.5\text{pu}$: is the apparent power.

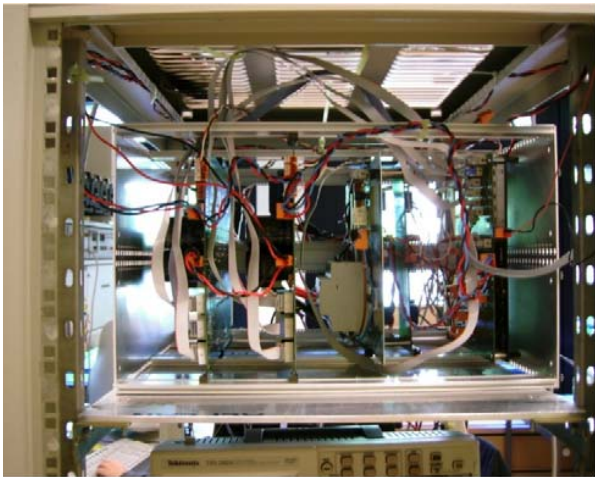

Fig. 12 A low voltage laboratory prototype

The same system as shown in Fig. 8 has been built and tested using a low voltage laboratory prototype. To replace the gas turbine a Direct Current Machine is used as power source, it is directly connected to the synchronous generator, which is

connected to the grid through an indirect static frequency converter with an intermediary DC circuit (see Fig. 12).

Fig. 13 to 15 and fig. 16 to 18 show respectively the simulated and the measured results, as well during transition between PWM and SWM controls, as in steady-state. In comparison with simulation results, the measured curves shown in Fig. 16, highlight a current spikes occurred when PWM and SWM controls switch together. This due to the difficulty of choosing well-defined transition timing. These spikes can be suppressed by an improved timing of the switching controls. This phenomenon has disappeared in simulation result (see Fig. 13), because it's very easy to detect a good timing during transition in simulation model than in real time model.

Fig. 14 and 17 show a simulated and respectively a measured active and reactive power for different operation modes. The line current is in phase with the network voltage when the reactive power is null.

Fig. 15 shows the simulated harmonic spectrum of the line and the generator current. As described in section II, by choosing the switching angles, the minimum of harmonics can be obtained at line side. The fifth harmonics can be disappeared in machine side. This advantage of decoupling of harmonics between the generator and the network currents is brought by the capacitive intermediary circuit.

V. CONCLUSION

In this paper a special frequency converter is proposed, that can be used for high power application and is characterized by a high efficiency. This efficiency is achieved by using a square wave modulation, which has the advantage of a quasi-absence of switching losses. In this mode, only the frequency can be varied between the input and the output voltage, but their magnitudes are not freely controllable. A voltage magnitude adaptation can be done by the generator's excitation. The produced active and reactive power can be controlled then by the generator excitation as well as both the angle shift between the generator and rectifier voltages and between the inverter and network voltages. The capacitive intermediary circuit brings the advantage of decoupling of harmonics between the generator and the network currents. Simulation and experimental results for different operating points and transitions between them highlight the capabilities of the proposed control strategy. These include the ability to operate high power application with unity power factor and better current quality with fewer harmonic.

A. Simulation Results

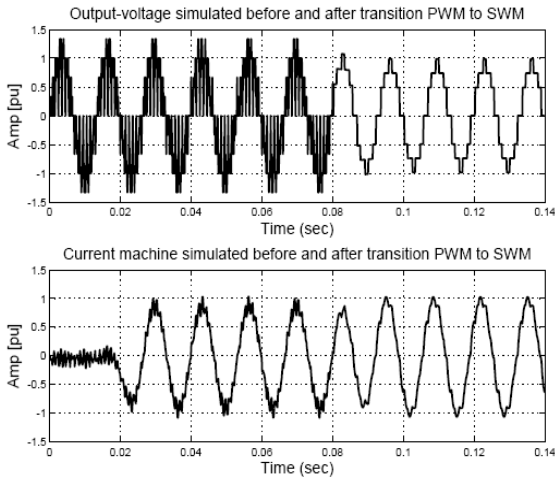

Fig. 13 Simulation results during transition between PWM and SWM

B. Practical Verification Results

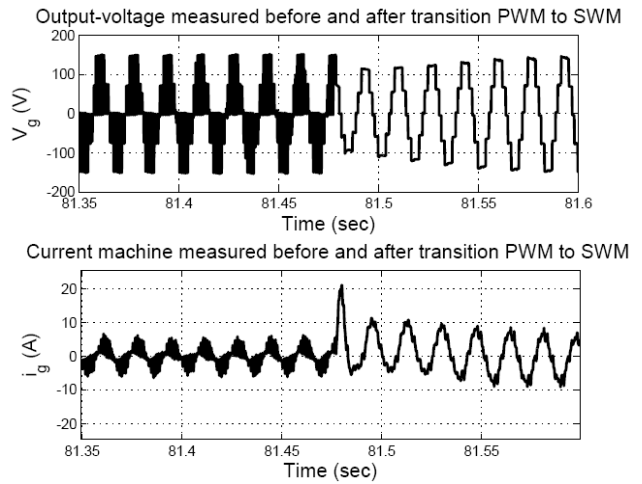

Fig. 16 Practical verification results during transition between PWM and SWM

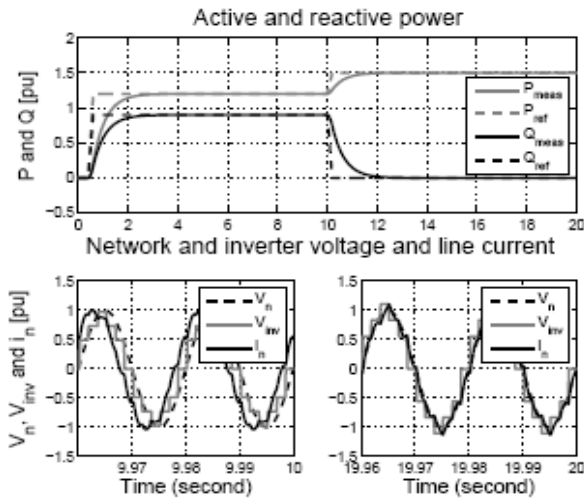

Fig. 14 Simulation results: (cos $\phi = 0.8$) and (cos $\phi = 1$)

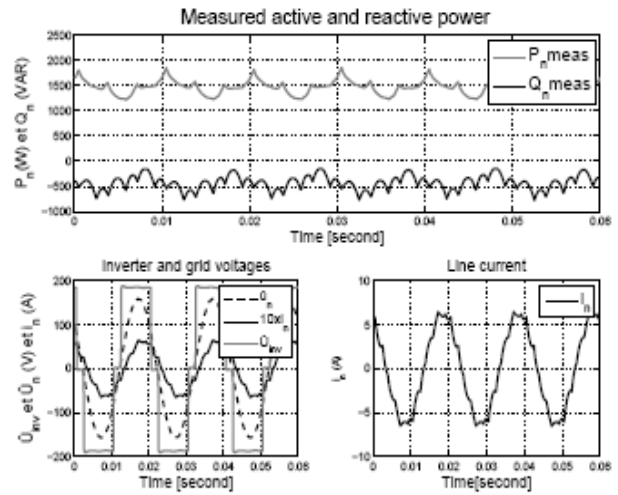

Fig. 17 Practical verification results: (cos $\phi = 0.8$)

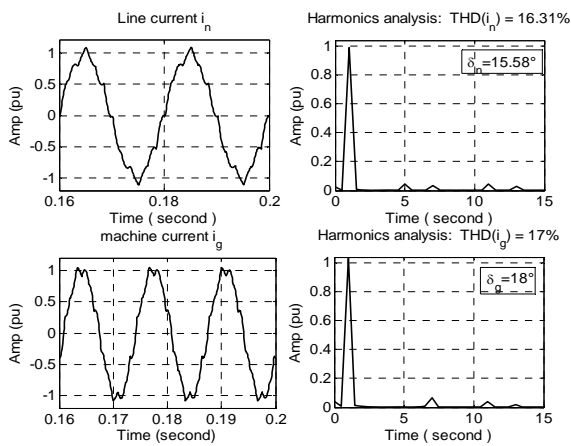

Fig. 15 Simulated currents in the line and in the machine side and its harmonic spectrum

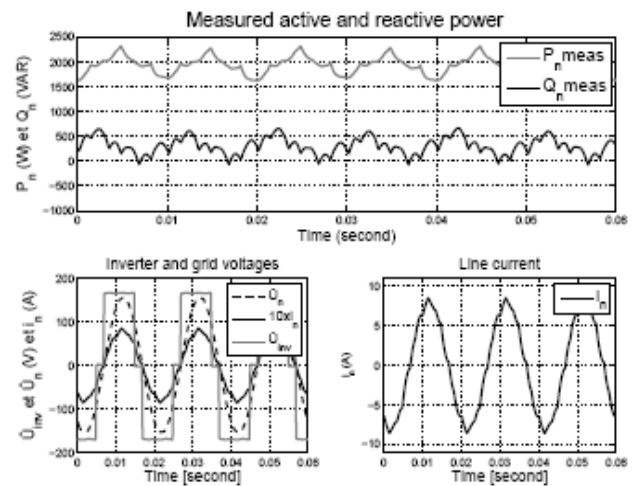

Fig. 18 Practical verification results: (cos $\phi = 1$)

REFERENCES

- [1] H. Winter and F. Rossig, "Entwicklung der Getriebe bei zu erwartenden Leistungssteigerungen" Allianz report, no.2, pp. 71-78, 1998.
- [2] Highly reliable and efficient turbo gear units", MAAG Gear AG: www.maa-gear.com, 2004.
- [3] F. Peneder, R. Lubasch, and A. Voumard, " Dispositif statique de demurrage pour centrales de pompage, compensateurs et turbogroupes à gaz", Rev. Brown Boveri 440-447, 9/10- 1974.
- [4] H. Stemmler, High-power industrial drives, proceeding of the IEEE, vol. 82, Issue 8, 1994, pp 1266-1286.
- [5] H. Stemmler, Variable speed, 3 phase drives fed by static frequency changers, state of the art and applications, Brown Boveri, Revue vol 67, issue 1 pp. 55-63, 1980.
- [6] C. Schauder, "Theory and design of 30-hp matrix converter", IEEE Transactions on industry Applications, vol.28 no 3, pp 546-551, 1992.
- [7] A. Schuster, "A matrix converter without reactive clamp elements for an induction motor drive system" PESC 98 Rec, 29th Annual IEEE 17-22 May 1998, vol.1 pages: 714 – 720.
- [8] S. Turri, "Etude d'un alternateur desynchrone" Thèse de Doctorat, U.F.R. des Sciences Techniques et Gestion de l'industrie de l'Université des Franche-Comte, Belfort, 03.11.2000.
- [9] M. Visintin, "The active generator principle for high power electric supply: properties and limitations", these EPFL, no. 3324, 2005.
- [10] O. Carlson and J. Hylander, "Variable speed AC-generators in wind energy converters", MELECON'89 Mediterranean, pp. (91-94), 11- 13 April 1989.
- [11] M. Dahlgren, "Production à grande échelle d'électricité d'origine éolienne », Revue ABB, pp. 31-37, Mars 2000.
- [12] R. H. Baker, "High-voltage converter circuit," U.S. Patent 4 203 151, May 13, 1980.
- [13] R. H. Baker, "Bridge converter circuit," U. S. Patent 4 270 163, May 26, 1981.
- [14] A. Nabae, I. Takahashi, and H. Akagi, "A neutral-point-clamped PWM inverter," in Conf. Rec. IAS Annu. Meeting, Cincinnati, OH, sep. 28-Oct.3, 1980, vol 3, pp. 761-766.
- [15] S. Kourou, J. Rodriguez, B. Wu, S. Bernet and M. Perez, "Powering the future of industry, High-power adjustable speed drive topologies", IEEE industry applications magazine 10 May 2012. Volume 18, pp. 26-39.
- [16] A. Benaboud, "convertisseur de fréquence indirect à rapport de tension fixe: interface entre turbo-alternateurs à haute vitesse et réseau électrique » Thèse n3733 EPFL, Lausanne 2007.
- [17] H. Bühler, Convertisseurs statiques. Lausanne: presses Polytechniques et Universitaires Romandes, 1991.
- [18] « ABB stakPak, H Series Press-pack IGBT 5SNR 20H2500, » ABB Industry : brochure and datasheet, Switzerland Ltd, 02 May 2004.
- [19] A. Benaboud, A. Rufer «A closed loop control strategy for a frequency-only converter with high efficiency », Proceeding of the seventh IASTED international conference, Power and energy systems, august 29-31,2007, palma de Mallorca, Spain. p.p:407- 412.
- [20] A. Benaboud, A. Rufer « New control strategy for three level NPC converter connected to the grid », proceedings of the Sixth IASTED International Conference, European power and energy systems, June 26-28, 2006, Rhodes, Greece, pp 400-405.
- [21] A. Benaboud, A. Rufer « Method of controlling a three level converter» patent n°US 7,800,926B2 sep.21, 2010.
- [22] PLECS, Piece-Wise Linear Electrical Circuit Simulation for simulink. User Manual GmbH, Zürich (ch) 2002, (<http://www.plexim.com>).