

# Optimal Criteria for Non-Minimal Phase Plants

Z. Nemeč, R. Matoušek

**Abstract**—The paper describes the evaluation of quality of control for cases of controlled non-minimal phase plants. Control circuits containing non-minimal phase plants have different properties, they manifest reversed reaction at the beginning of unit step response. For these types of plants are developed special criterion of quality of control, which considers the difference and can be helpful for synthesis of optimal controller tuning. All results are clearly presented using Matlab/Simulink models.

**Keywords**—control design, non-minimal phase system, optimal criteria, power plant, heating plant, water turbine, Matlab, Simulink.

## I. INTRODUCTION

THE choice of controller parameters tuning is an important part of solution of control circuit. Tuning of the controller should be optimal or at least quasi-optimal from the point of view of the chosen qualitative requirements. The requirements for quality of control can be defined by differently depending on the objective of the control.

Control quality criterion is often based on step response. In the simplest cases it can be evaluated the time of control, overshoot and so on. For more objective evaluation of control quality there are used integral criteria which consider whole step response. Examples of basic performance integral criteria for optimal control design are in Table I., where  $\mathbf{k}$  is the controller parameters vector.

TABLE I  
COMMON INTEGRAL OBJECTIVE FUNCTIONS (INTEGRAL CRITERIA)

Index	Caption	Formula
ISE	<i>Integral of Squared Error</i>	$f_{ISE}(\mathbf{k}) = \int_0^t e^2(t) dt$
IAE	<i>Integral of Absolute Error</i>	$f_{IAE}(\mathbf{k}) = \int_0^t  e(t)  dt$
ITSE	<i>Integral of Time multiply Squared Error</i>	$f_{ITSE}(\mathbf{k}) = \int_0^t te^2(t) dt$
ITAE*	<i>Integral of Time multiply Absolute Error</i>	$f_{ITAE}(\mathbf{k}) = \int_0^t t e(t)  dt$

\* This control error criteria was used in our experiments as  $J_p$ .

All authors are from Brno University of Technology, Faculty of Mechanical Engineering, Dept. of Automation and Applied Computer Science, Technická 2896/2, 61669 Brno, Czech Republic, corresponding author have e-mail matousek@fme.vutbr.cz.

This work was supported by the research projects of MSM 0021630529 "Intelligent Systems in Automation", GACR No.: 102/091668 "Evolutionary Control Design", and IGA (Internal Grant Agency of Brno University of Technology) FSI-S-11-31 "Application of Artificial Intelligence".

This paper deals with the issue of evaluation of quality of control with controlled systems designated as systems with non-minimum phase. Control circuit with non-minimal phase plants have different behavior compared with circuits with classic controlled systems, which we denoted in this context as minimum phase systems. Analyzed circuits have at the beginning of unit step response an interval of negative action, which can be called as the effect of under-control. Common criteria of quality (Table I.) evaluate this interval with the same weight as other intervals of the response. However such practice is not suitable because this interval is very important and it is advisable to take it into account with higher priority (weight) in the quality evaluation.

However such practice is not suitable because this interval is very important and it is advisable to take it into account with higher priority (weight) in the quality evaluation. Usage of presented criterion of quality is similar to common integral criteria. Such methods are useful in computer aided optimization for controller parameters tuning, as optimal it is considered the values of parameters to give the minimal value of quality criterion (1), where the vector  $\mathbf{k}^*$  corresponds to find optimum controller parameters, e.g. in PID controller it is represent three parameters (proportional, derivative and integral constants).

$$\mathbf{k}^* = \arg \min_{\mathbf{k} \in \mathbb{R}^3} J(\mathbf{k}) \quad (1)$$

## II. INDUSTRIAL EXAMPLES OF NON-MINIMAL PHASE PLANTS

The performance of a PID controller which are use in common industrial applications degrades for plants exhibiting non-minimum phase behaviour.

There can be found different cases of non-minimal phase plants in the real industry [1], [2], [3] and [8]. In this paper we will present examples of controller designs for plants from the area of power engineering. Right in applications of power engineering the non-minimal phase plants occur very often. An inverse response can be also find in some aircraft regarding the step response of the elevator deflection to pitch angle [4].

### A. Tank boiler in power plant or heat station

A specific inverse response is found in tank boiler level control systems. If the controlled variable is level of water in tank boiler with pressure steam and input (action variable) is inflow of feeding water then step response has typical shape of a non-minimal phase plant according to Fig 1.

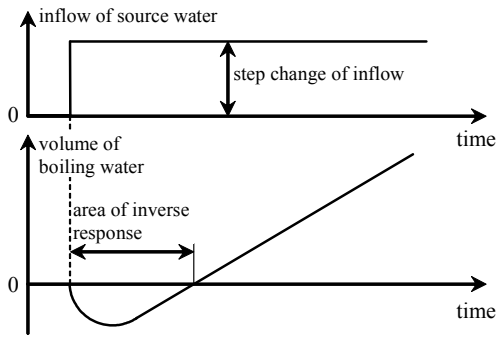

Fig. 1 Negative (inverse) response of tank boiler level control system. An inverse response occurs when the flow rate of the feed water is increased by a step change, and the total volume of boiling water decreases for a short period

**B. Water turbine**

If the controlled variable is active power and machine unit is connected to electric system, the input is opening of turbine and step response contains quite spiky interval of negative (inverse) response according to Fig. 2.

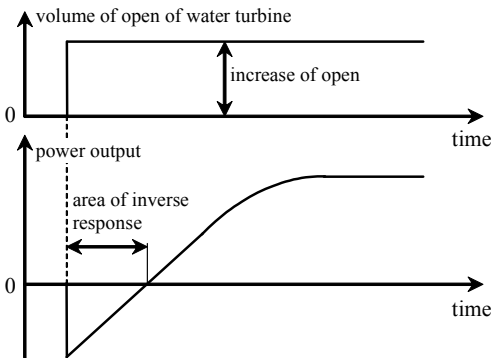

Fig. 2 Negative (inverse) response of water turbine power control system. An inverse response occurs when the water turbine is activated, i.e. connected to power system

If  $Y(s)$  and  $U(s)$  are Laplace's images of output and input of plant and  $\tau$  time constants of plants, then respective step responses have shape  $G_{TankBoiler}$  and  $G_{WaterTurbine}$  by (2) and (3).

$$G_{TankBoiler}(s) = \frac{Y(s)}{U(s)} = \frac{(1 - \tau_1 s)}{(1 + \tau_2 s) \cdot \tau_3 s} \quad (2)$$

$$G_{WaterTurbine}(s) = \frac{Y(s)}{U(s)} = \frac{(1 - \tau_1 s)}{(1 + \tau_2 s)} \quad (3)$$

Inclusion of controlled plants according to (2) or (3) into control circuits will manifest also in step response of closed control loop.

**III. DESIGN OF OPTIMAL INTEGRAL CRITERIA**

Design of control quality criterion have to be complex, i.e. it must consider improper shapes of step response and their importance, Fig. 3. Based on the experiments and theoretical and practical experience we have developed for the plants according to (2) and (3) the criterion considering whole control process, under-control in the beginning of control and also shape of action variable.

$$J(\mathbf{k}) = J_p(\mathbf{k}) + J_N(\mathbf{k}) + J_U(\mathbf{k}) \quad (4)$$

Where  $J_p(\mathbf{k})$  is factor which evaluates positive area of step response,  $J_N(\mathbf{k})$  is factor which evaluates negative area of step response and  $J_U(\mathbf{k})$  is factor which evaluates change of action variable, i.e. penalty of extensive control changes.

Objective function (4) is created as sum of penalizing functions, whereas compound  $J_p(\mathbf{k})$  is considered base and other compounds are weighted using coefficient  $w$  and relevant power coefficient  $m$ .

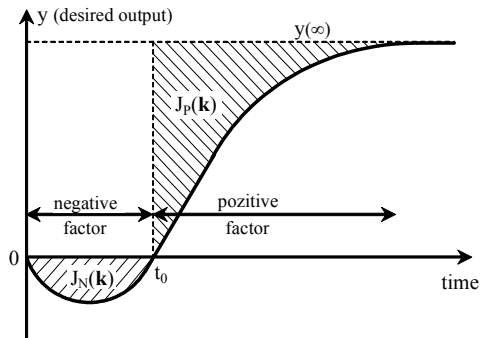

Fig. 3 An example of unit step response and sketch for definitions of optimal integral criteria  $J_N(\mathbf{k})$  and  $J_p(\mathbf{k})$ .

Evaluation of positive area  $J_p(\mathbf{k})$  is proposed (5) likewise as for common criteria according to Table I, concretely  $f_{ITAE}$ , but time interval starts form  $t_0$ .

$$J_p(\mathbf{k}) = \int_{t_0}^{\infty} |y(\infty) - y(t)|^{m_p} (t - t_0) dt \quad (5)$$

Newly is included factor  $J_N(\mathbf{k})$  considering atypical negative part of step response (6). Important is the restricted effect of this criterion from the beginning of process to the time  $t = t_0$

$$J_N(\mathbf{k}) = w_N^{m_N} \cdot \int_0^{t_0} |y(t)|^{m_N} dt \quad (6)$$

Third factor  $J_U(\mathbf{k})$  of the criterion (4) penalizes changes of action variable and it is computed for whole time response (7).

$$J_U(\mathbf{k}) = w_A^{m_A} \cdot \int_0^{\infty} \left| \frac{du(t)}{dt} \right|^{m_A} dt \quad (7)$$

Robustness of presented criteria to deviation of given estimation parameter is designated by power parameter  $m$ . For example for common integral criterion ITAE would be  $m_P = 1$ . Effect of this coefficient to robustness of estimation including other properties can be found in [6].

As you can see by criterion function (4) the result of optimization of parameters  $k$  can be influenced by choice of weights  $w$  and powers  $m$ . Right choice of weights  $w_N, w_A$  and powers  $m_P, m_N, m_A$  requires certain experience and wider analytical skills in area of understanding control tasks.

Combined weight coefficients  $w_N$  and  $m_N$  designates the scale of magnitude of under-control to overall quality of control and so it is for given analysis the most important. Therefore it is proper in setting of suitable weight parameters to choose  $w_N$  as last free parameter and to set the  $w_N$  for obtaining  $J_N(k)$  in comparable size to  $J_P(k)$ , as can be seen in Table II.

Weight  $w_U$  is chosen considering the magnitude of action variable factor. For example if changes of size of action variable cause mechanical movements and it results in higher amortization of technology, then higher weight is proper. However if frequent and big changes of action variable does not matter then the weight can be chosen small or zero as in the example further presented.

IV. MATLAB/SIMULINK IMPLEMENTATION

For simulation modeling and verification of effectiveness of designed criteria is chosen the environment Matlab/Simulink which is in the area of control design and model design commonly used.

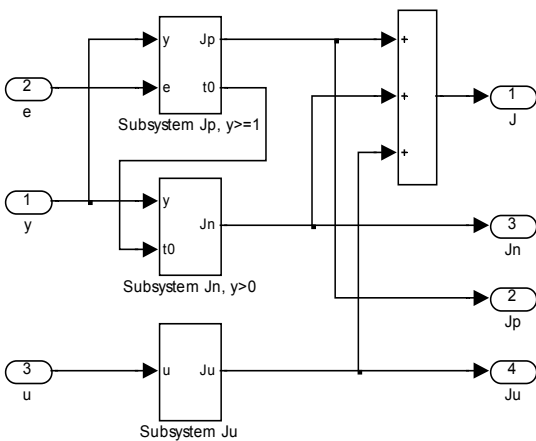

Fig. 4 Simulink model of complete objective function  $J(k)$

To objective functions given by (5), (6) and (7) from previous section has been developed model schemas. Model representing optimal criteria (4) is hierarchically organized, higher level is demonstrated in Fig. 4, lower levels with detailed schemas are for individual objective functions in Fig. 5. To input designated  $y$  is from control circuit supplied the change of controlled value, to input  $e$  is supplied control

error (difference of set point and real value of controlled variable) and to input  $u$  is supplied change of action variable as output from the controller. It is assumed at the beginning of response all values are zero.

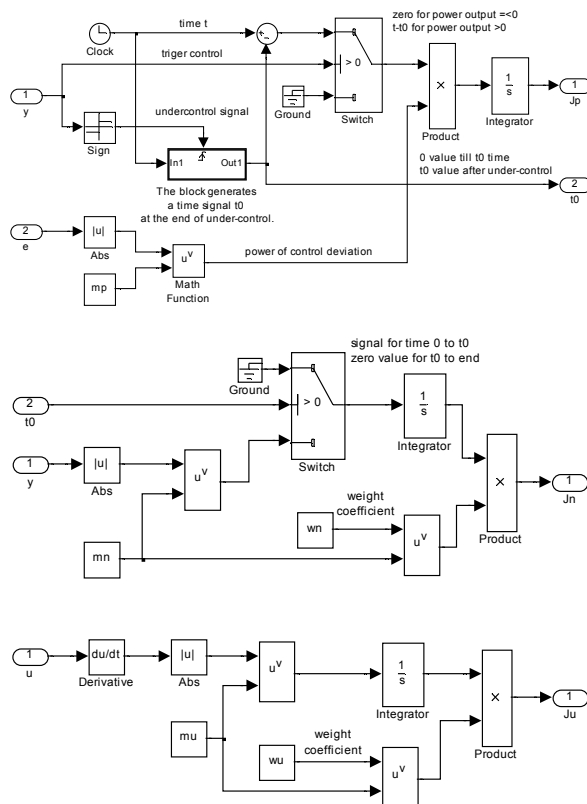

Fig. 5 Details of Simulink model implementations which are use like optimal criteria.  $J_P$  objective function is standard integral criteria for positive part of step response (top).  $J_N$  objective function is integral criteria for negative part of step response (middle).  $J_U$  objective function is penalization of inapt control action, this criteria does not important for presented industrial plant and given control design (bottom)

V. TESTS AND RESULTS

For our experiment we consider control of level of water in tank of power plant, heat station or incinerator boiler. Action variable is inflow of feeding water to boiler, error variable (variable which inauspiciously affects controlled level) is the take of steam. Respective schema of regulation circuit is in Fig. 6. Transfer functions of controlled plants and given parameters are partially simplified which is acceptable for purposes of presentation of criterion.

TABLE II  
PROPERTIES OF CONTROL DEPENDING ON CHOSEN WEIGHT OF UNDER-CONTROL (WHERE  $m_p=2, m_n=3, w_u=0$ )

weight $v_n$ for negative part	optimal parameters tuning*		under-control (9%) (input = 100%)	objective functions values		show in Fig. 8
	$T_1$ (s)	$K_p$ (-)		$J_n$	$J_p$	
0	0	1.32	-29.2	0	597	✓
100	3	1.2	-25.4	602	794	
150	10	1.1	-20.8	1186	1242	
200	20	1.02	-16.4	1459	2171	✓
300	25	0.9	-13.2	2689	3362	
350	30	0.88	-12.0	3298	4064	
500	40	0.80	-9.6	5019	6627	
700	50	0.75	-8.0	8220	9694	
1000	60	0.65	-6.2	11534	16698	✓

\* There was used Nelder-Mead algorithm by Matlab.

By more detailed analysis can be found out the usage of classic PID controller (transfer proportionally integrally derivative) is in this case improper. Derivative factor would increase the magnitude of under-regulation and integration factor is not very suitable considering integral character of controlled plant. Therefore we consider PT1 type controller, i.e. proportional controller with inertia of first order. So for controller can be set two variables – proportional gain  $K_p$  and time constant of inertia  $T_1$ . In process of optimization we search for such values of parameters the quality criterion function have the lowest possible value.

In Table II are results of optimization of transfer of controller tabled in rows for different values of weight  $w_N$  according to (6) (negative area of step response). First row is close to classic solution according to  $f_{ITAE}$  which does not distinguish negative and positive part of step response. Optimization process of variables  $K_p$  and  $T_1$  is reached only with contribution of function  $J_p$ . However the last row of table corresponds to optimization with great emphasis to demanded low value of under-regulation. Of course the most advantageous is a compromise between presented extremes.

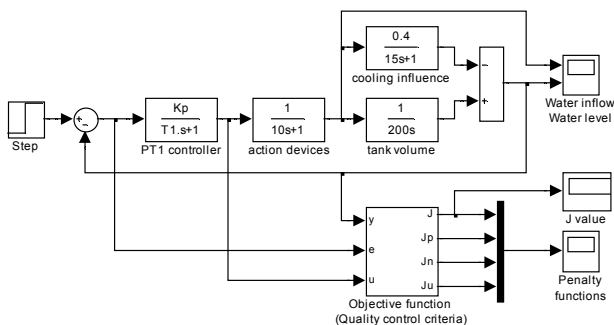

Fig. 7 Complex model of control loop system including controller, plant and objective function block as optimal criteria for control design

Approximately in the middle of the table we can search for suitable compromise where value of factor  $J_p$  is increased but size of extreme of under-control of water level is decreased from 29.2% to 16.4%.

Let's note for optimization of parameters were used basic solvers from Matlab/Simulink, e.g. non linear solver fminsearch which use Nelder-Mead algorithm. Also another most sophisticated soft-computing algorithm as differential evolution, HC12 etc. can be used, [7] and [9].

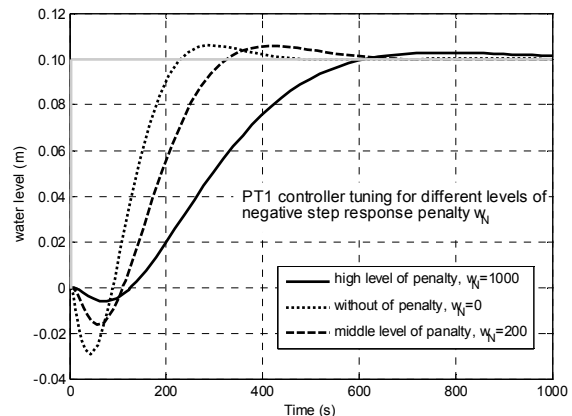

Fig. 8 Optimal step responses of water level control for different values of under-control factor weights

In Fig. 8 are three step responses with optimal values of  $K_p$  a  $T_1$ . Those responses correspond to three levels of penalties of under-control according to Table II. It is obvious that by means of choice of weight  $w_n$  can be reduced the effect of under-control in big enough interval. This is the goal in design of modified quality criterion. By reducing unwanted effect in the beginning of characteristics is paid for by decreasing quality in the rest of the (positive) area of step response.

## VI. RESULTS

There are many methods for controller circuit synthesis [5]. Lately the solutions with computer aided design are in favor. Apart from the efficiency of work there are other conceptual advantages – to solution can be easily included optimization of parameters and it is possible to use numerical methods or soft-comof solution which widens possibilities of more complex nonlinear quality criterions.

For optimization of controller tuning is necessary to specify criteria for optimum searching and evaluation of results in the process of optimization. Presented paper dealt with problem of choice of suitable control quality criterion for plants which are difficult to control – non-minimal phase plants. For this group of plants it is proper to extend the common integral criterion of quality with a factor for specific effect of under-control. For the ease of verification and further usability was in the paper presented whole schema of models created in the Matlab/Simulink environment. Benefit of presented criterion is apparent from Fig. 8.

## APPENDIX

All stable Linear Time Invariant (LTI) systems, which can be described using the transfer function  $G(s) = N(s)/D(s)$  and which don't have zeros in the right (positive) half  $s$  plane are denoted as minimum phase systems. There is the reality that for a known amplitude response  $A(\omega) = |G(j\omega)|$  in the range of  $\omega \in [0, \infty)$  the corresponding phase response  $\varphi(\omega)$  can be calculated from  $A(\omega)$  and that the value of  $\varphi(\omega)$  determined has its minimum modulus for given  $A(\omega)$ .

If the transfer function has one or more zeroes in the right (positive) half  $s$  plane then the system represent non-minimum phase behaviour. The modulus of the phase response is then always larger than for a system with minimum phase behaviour, which has the same amplitude response.

In case of to illustrate the non-minimum phase behaviour two systems would be considered by (8). There are examples of transfer functions  $G_1(s)$  as minimum phase system and  $G_2(s)$  as non-minimum phase system.

$$G_1(s) = \frac{1+sT}{1+sT_z} \quad G_2(s) = \frac{1-sT}{1+sT_z} \quad 0 < T < T_z \quad (8)$$

The amplitude response of the corresponding frequency responses is in the both cases similar by (9) but the phase response is different by (10) and Fig. 9.

$$A_1(\omega) = A_2(\omega) = \sqrt{\frac{1+(\omega T)^2}{1+(\omega T_z)^2}} \quad (9)$$

$$\varphi_1(\omega) = -\arctan \frac{\omega(T_z - T)}{1 + \omega^2 T_z T} \quad \varphi_2(\omega) = -\arctan \frac{\omega(T_z + T)}{1 + \omega^2 T_z T} \quad (10)$$

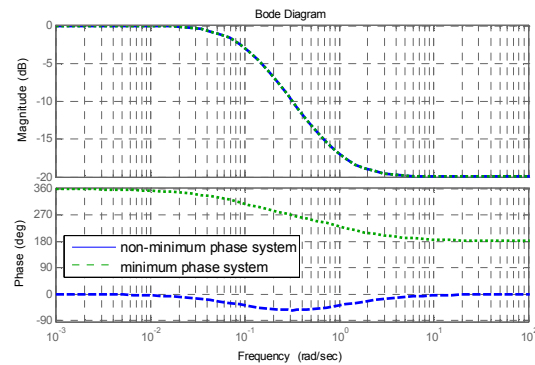

Fig. 9 The phase responses of transfer functions  $G_1(s)$  and  $G_2(s)$  with identical amplitude but with minimum and non-minimum phase behaviour  $|\varphi_1(\omega)| < |\varphi_2(\omega)|$

## REFERENCES

- [1] M. Fliess, H. Ramirez, R. Marquez, "Regulation of non minimum phase outputs: a flatness approach", In *Perspectives in Control Theory & Applications*, Colloquium in Honor of I. D. Landau, Paris, Springer-Verlag, Berlin 1998
- [2] K. J. Astrom, "Direct methods for non-minimum phase systems", In *19th IEEE Conference on Decision and Control including the Symposium on Adaptive Processes*, vol.19, pp.611-615, Dec. 1980
- [3] M. Benosman, F. Liao, K.-Y. Lum and J. Liang Wang, "Nonlinear Control Allocation for Non-Minimum Phase Systems", In *IEEE Transactions on Control Systems Technology*, vol.17, no.2, pp.394-404, Mar. 2005
- [4] G. F. Franklin, D. G. Powell, A. Neini, *Feedback Control of Dynamic Systems*, 6th edn, Prentice Hall PTR, Upper Saddle River, USA, 2010.
- [5] K. J. Astrom, "Direct methods for non-minimum phase systems", In *19th IEEE Conference on Decision and Control including the Symposium on Adaptive Processes*, vol.19, pp.611-615, Dec. 1980
- [6] R. Matousek, Z. Karpisek, "Exotic Metrics for Function Approximation", In *17th International Conference on Soft Computing - MENDEL 2011*, pp. 560 565, June 2011
- [7] P. Popela, J. Dupacova, "Melt Control: Charge Optimization via Stochastic Programming". In *W. Zieamba. et al. (eds.): Applications of Stochastic Programming*, Chapter 15, pp. 277-289, SIAM, 2005
- [8] R. Grepl, J. Vejluppek, V. Lambersky, M. Jasansky, F. Vadlejch, P. Coupek, P. "Development of 4WS/4WD Experimental Vehicle: platform for research and education in mechatronics". *IEEE International Conference on Mechatronics. ICM 2011-13-15, 2011.*
- [9] Z. Oplatkova, R. Senkerik, I. Zelinka, "Synthesis of Control Rule for Synthesized Chaotic System by means of Evolutionary Techniques", in *16th Int. Conference on Soft Computing*, pp.91-98, Brno, 2010.