

The Comparison Study of Harmonic Detection Methods for Shunt Active Power Filters

K-L. Areerak and K-N. Areerak

Abstract—The paper deals with the comparison study of harmonic detection methods for a shunt active power filter. The %THD and the power factor value at the PCC point after compensation are considered for the comparison. There are three harmonic detection methods used in the paper that are synchronous reference frame method, synchronous detection method, and DQ axis with Fourier method. In addition, the ideal current source is used to represent the active power filter by assuming an infinitely fast controller action of the active power filter. The simulation results show that the DQ axis with Fourier method provides the minimum %THD after compensation compared with other methods. However, the power factor value at the PCC point after compensation is slightly lower than that of synchronous detection method.

Keywords—Harmonic detection, shunt active power filter, DQ axis with Fourier, power factor.

I. INTRODUCTION

POWER systems connected nonlinear loads can generate the harmonics into the systems. These harmonics cause a lot of disadvantages such as loss in transmission lines and electric devices, protective device failures, and short-life electronic equipments in the system [1]. Therefore, it is very important to reduce or eliminate the harmonics in the system. It is well known that the harmonic elimination via an active power filter (APF) [2] as shown in Fig.1. There are three main parts for using the active power filter. The first is the harmonic detection method to identify harmonic quantity in the system. The second part is the active power filter structure and the last one is the control technique to control the injecting current to the power system.

The active power filter provides higher efficiency and more flexible compared with a passive power filter. In Fig.1, the three-phase bridge rectifier feeding resistive and capacitive loads ($R=3.37 \text{ k}\Omega$ and $C=4.7 \text{ }\mu\text{F}$) behaves as a nonlinear load into the power systems. An ideal current source is used to represent the active power filter by assuming an infinitely fast controller action of the active power filter. Therefore, the compensating currents from the active power filter are equal to the reference currents calculated from the harmonic detection methods. The aim of this paper is to present the comparison study of the various harmonic detection methods with the ideal

current source. There are three harmonic detection approaches in the paper that are synchronous reference frame (SRF) method [3], synchronous detection (SD) method [4], and DQ axis with Fourier (DQF) method [5]. The DQF algorithm has been reported since 2007 [5] in which it confirms that the DQF method is the best approach compared with SRF and SD methods to achieve the minimum %THD of the source current after compensation. In this paper, the power factor at the PCC point after compensation is taken into account with %THD for the comparison between the DQF method and other harmonic detection methods.

The paper is structured as follows. The reviews of harmonic detection method used in the paper are addressed in section II. Performance indexes for the comparison are described in section III. The simulation results of the harmonic elimination with the various harmonic detection methods including discussion are presented in section IV. Finally, section V concludes the advantages and disadvantages of the DQF approach to calculate the reference currents for the active power filter.

II. REVIEWS OF HARMONIC DETECTION METHODS

A. Synchronous Reference Frame (SRF)

The transformation from 3-axis to 2-axis is mainly used for the SRF method. There are five steps to calculate the reference currents for a shunt active power filter using the SRF method.

Step 1: Transform the three-phase load currents (i_{La} , i_{Lb} , i_{Lc}) to $\alpha\beta 0$ frame ($i_{L\alpha}$, $i_{L\beta}$, i_{L0}) by:

$$\begin{bmatrix} i_{L\alpha} \\ i_{L\beta} \\ i_{L0} \end{bmatrix} = \sqrt{\frac{2}{3}} \begin{bmatrix} 1 & -\frac{1}{2} & -\frac{1}{2} \\ 0 & \frac{\sqrt{3}}{2} & -\frac{\sqrt{3}}{2} \\ \frac{1}{\sqrt{2}} & \frac{1}{\sqrt{2}} & \frac{1}{\sqrt{2}} \end{bmatrix} \begin{bmatrix} i_{La} \\ i_{Lb} \\ i_{Lc} \end{bmatrix} \quad (1)$$

Step 2: Transform the $i_{L\alpha}$ and $i_{L\beta}$ to the dq-axis by:

$$\begin{bmatrix} i_{Ld} \\ i_{Lq} \end{bmatrix} = \begin{bmatrix} \cos(\omega t) & \sin(\omega t) \\ -\sin(\omega t) & \cos(\omega t) \end{bmatrix} \begin{bmatrix} i_{L\alpha} \\ i_{L\beta} \end{bmatrix} \quad (2)$$

K-L. Areerak and K-N. Areerak are with the Power Quality Research Unit, School of Electrical Engineering, Institute of Engineering, Suranaree University of Technology, 111 University Avenue, Muang District, Nakhon Ratchasima 30000, Thailand.

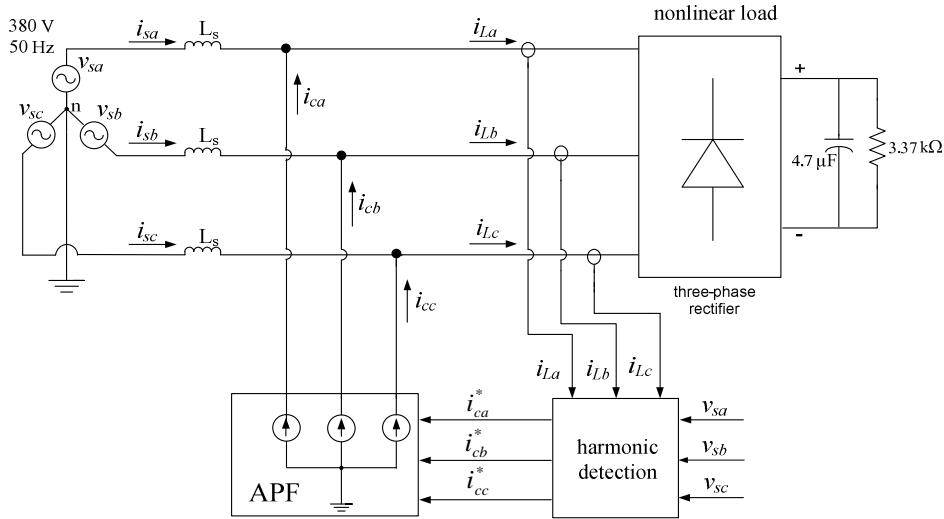

Fig.1 Power system considered

when ω is the fundamental frequency of the system (rad/s). The vector diagram for dq-transformation is depicted in Fig.2.

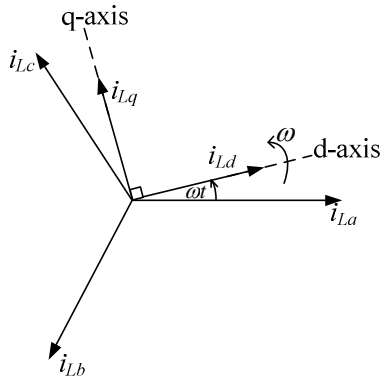

Fig.2 Vector diagram for dq-transformation of load currents

In Fig.2, the i_{Ld} and i_{Lq} consists of two terms, the fundamental and harmonic terms. For harmonic terms, it means all harmonics are included behaving as an AC component, while the fundamental terms behave as a DC component. The equations to explain these load current on dq-frame are:

$$\begin{bmatrix} i_{Ld} \\ i_{Lq} \end{bmatrix} = \begin{bmatrix} \bar{i}_{Ld} + \tilde{i}_{Ld} \\ \bar{i}_{Lq} + \tilde{i}_{Lq} \end{bmatrix} \quad (3)$$

when \bar{i}_{Ld} , \bar{i}_{Lq} and \tilde{i}_{Ld} , \tilde{i}_{Lq} are the DC components and AC component of the load currents on dq-frame, respectively.

Step 3: From Step 2, it is shown that the dq load currents consist of two terms. For this step, the high-pass filter (HPF) is

used to separate the harmonic components (\tilde{i}_{Ld} , \tilde{i}_{Lq}) from the dq load currents (i_{Ld} , i_{Lq}) as shown in Fig.3.

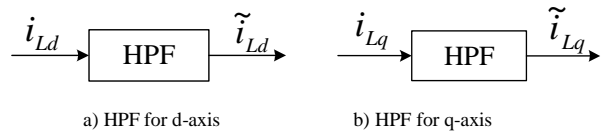

Fig.3 Separation of harmonic components on dq-frame

Note that the idea for selecting the cutoff frequency of the HPF can be found in [6].

Step 4: Transform the harmonic currents on dq-frame (\tilde{i}_{Ld} , \tilde{i}_{Lq}) from Step 3 to $\alpha\beta$ -frame ($\tilde{i}_{L\alpha}$, $\tilde{i}_{L\beta}$) by:

$$\begin{bmatrix} \tilde{i}_{L\alpha} \\ \tilde{i}_{L\beta} \end{bmatrix} = \begin{bmatrix} \cos(\omega t) & -\sin(\omega t) \\ \sin(\omega t) & \cos(\omega t) \end{bmatrix} \begin{bmatrix} \tilde{i}_{Ld} \\ \tilde{i}_{Lq} \end{bmatrix} \quad (4)$$

Step 5: Calculate the three-phase reference currents (i_{ca}^* , i_{cb}^* , i_{cc}^*) for a shunt active power filter (SAPF). These currents are then used as the input for SAPF to compensate the harmonic of the power system as shown in Fig.1. The purposed reference currents can be determined from the harmonic currents on $\alpha\beta$ -frame ($\tilde{i}_{L\alpha}$, $\tilde{i}_{L\beta}$) from Step 4 and the zero current (i_{L0}) from Step 1 by:

$$\begin{bmatrix} i_{ca}^* \\ i_{cb}^* \\ i_{cc}^* \end{bmatrix} = \sqrt{\frac{2}{3}} \begin{bmatrix} 1 & 0 & \frac{1}{\sqrt{2}} \\ -\frac{1}{2} & \frac{\sqrt{3}}{2} & \frac{1}{\sqrt{2}} \\ -\frac{1}{2} & -\frac{\sqrt{3}}{2} & \frac{1}{\sqrt{2}} \end{bmatrix} \begin{bmatrix} \tilde{i}_{L\alpha} \\ \tilde{i}_{L\beta} \\ i_{L0} \end{bmatrix} \quad (5)$$

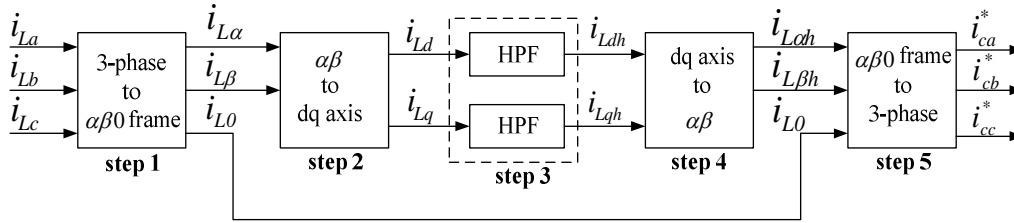

Fig.4 SRF harmonic detection

The SRF harmonic detection method can be reasonably summarized as a block diagram as shown in Fig.4.

B. Synchronous Detection (SD)

There are four steps of the SD approach for a harmonic detection as follows:

Step 1: The assumption of SD method is that the source currents (i_{sa}, i_{sb}, i_{sc}) after compensation are balanced as given by:

$$\begin{bmatrix} i_{sa} \\ i_{sb} \\ i_{sc} \end{bmatrix} = \begin{bmatrix} I_s \sin(\omega t + \phi) \\ I_s \sin(\omega t + \phi - 120^\circ) \\ I_s \sin(\omega t + \phi + 120^\circ) \end{bmatrix} \quad (6)$$

where I_s is the amplitude of a source current (A), ω is the fundamental system frequency (rad/s), and ϕ is the phase angle of the source current (degree).

Step 2: Calculate the three-phase reactive power as follow:

$$\begin{bmatrix} p_a \\ p_b \\ p_c \end{bmatrix} = \frac{P_{dc}}{V_{tot}} \begin{bmatrix} V_{sa} \\ V_{sb} \\ V_{sc} \end{bmatrix} \quad (7)$$

where V_{sa}, V_{sb} , and V_{sc} are the amplitude of three-phase voltage source, V_{tot} is the summation of the amplitude of three-phase voltage source ($V_{tot} = V_{sa} + V_{sb} + V_{sc}$), and P_{dc} is the fundamental component of the active power separated from the harmonic components by using the low pass filter as shown in Fig.5.



Fig.5 Separation of fundamental component from harmonic components

In Fig.5, the three-phase active powers ($P_{3\phi}$) can be calculated by:

$$P_{3\phi} = v_{sa}i_{La} + v_{sb}i_{Lb} + v_{sc}i_{Lc} \quad (8)$$

Step 3: Calculate the three-phase source currents by:

$$i_{sa} = \frac{2v_{sa}P_a}{V_{sa}^2} \quad (9)$$

$$i_{sb} = \frac{2v_{sb}P_b}{V_{sb}^2} \quad (10)$$

$$i_{sc} = \frac{2v_{sc}P_c}{V_{sc}^2} \quad (11)$$

Step 4: Calculate the reference currents ($i_{ca}^*, i_{cb}^*, i_{cc}^*$) for the active power filters by:

$$i_{ca}^* = i_{La} - i_{sa} \quad (12)$$

$$i_{cb}^* = i_{Lb} - i_{sb} \quad (13)$$

$$i_{cc}^* = i_{Lc} - i_{sc} \quad (14)$$

From Step 1 to Step 4, the SD approach can be summarized as the block diagram as shown in Fig. 6.

C. DQ axis with Fourier method (DQF)

The harmonic detection via DQF method [5] is developed from the SRF method. This algorithm is a combination of the advantages of the SRF method [3] and the sliding window Fourier analysis (SWFA) [7]. The DQF method can be explained as a block diagram in Fig.7.

In Fig. 7, it can be seen that the SWFA method is used to separate the harmonic currents ($\tilde{i}_{Ld}, \tilde{i}_{Lq}$) from the fundamental currents ($\bar{i}_{Ld}, \bar{i}_{Lq}$). There are five steps for DQF method to calculate the reference currents for the shunt active power filter.

Step 1: Three phase harmonic currents are transformed to the $\alpha\beta 0$ frame by (1).

Step 2: Only the currents on α and β axes are then transformed to the synchronously rotating dq frame by (2). Note that the Step 1 and Step 2 of the DQF method are the same as those of SRF method.

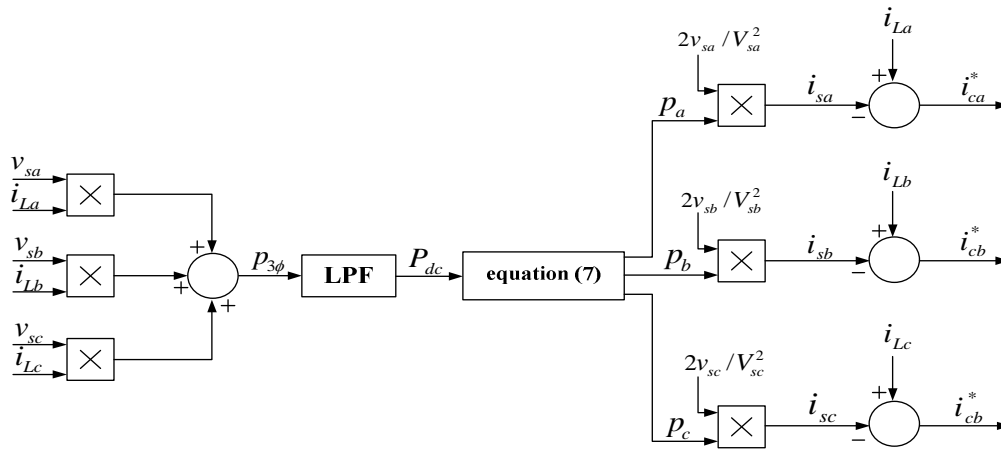

Fig. 6 SD method

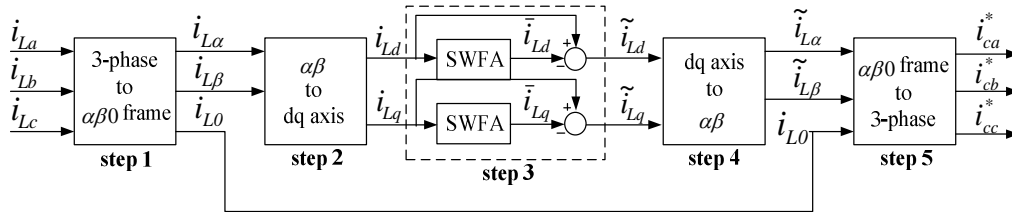

Fig.7 DQF method

Step 3: The harmonic currents are separated from the fundamental current by using SWFA method. The first step of SWFA technique considers the Euler-Fourier formulas as given by:

$$i_L(kT) = \frac{A_0}{2} + \sum_{h=1}^{\infty} [A_h \cos(h\omega_0 kT) + B_h \sin(h\omega_0 kT)] \quad (15)$$

where A_0 , A_h , and B_h are the coefficients of Fourier series, ω is the fundamental frequency (rad/s), h is the harmonic orders ($h=1$ for fundamental component), T is a sampling interval (s), and k is a time index. It can be seen that the current in (15) consists of DC component (fundamental current) and AC components (harmonic current). In Fig. 7, the SWFA method is used to determine the fundamental currents on dq frame ($\bar{i}_{Ld}, \bar{i}_{Lq}$). Therefore, the only A_0 coefficient in (15) is calculated to achieve the fundamental components by using (16) with setting h equal to 0.

$$A_h = \frac{2}{N} + \sum_{n=N_0}^{N_0+N-1} i_L(nT) \cos(nh\omega_0 T) \quad (16)$$

As a result, the fundamental currents on dq frame ($\bar{i}_{Ld}, \bar{i}_{Lq}$) from the SWFA method can be calculated by:

$$\bar{i}_{Ld}(kT) = \frac{A_{0d}}{2} \quad (17)$$

$$\bar{i}_{Lq}(kT) = \frac{A_{0q}}{2} \quad (18)$$

The A_{0d} and A_{0q} in (17) and (18) can be easily obtained by:

$$A_{0d} = \frac{2}{N} + \sum_{n=N_0}^{N_0+N-1} i_{Ld}(nT) \quad (19)$$

$$A_{0q} = \frac{2}{N} + \sum_{n=N_0}^{N_0+N-1} i_{Lq}(nT) \quad (20)$$

In (16)-(18), N_0 is the starting point for computing, N is the total number of sampled points in one cycle, and k is the time index. A_{0d} and A_{0q} for the first period can be calculated as given in (19) and (20), respectively so as to achieve the initial value for the DQF algorithm. For the next period, these values can be calculated by using (21) in which this approach called SWFA. The more details of SWFA can be found in [7].

$$\begin{bmatrix} A_{0d}^{(new)} \\ A_{0q}^{(new)} \end{bmatrix} = \begin{bmatrix} A_{0d}^{(old)} \\ A_{0q}^{(old)} \end{bmatrix} - \frac{2}{N} \begin{bmatrix} i_{Ld}(N_0 - 1)T \\ i_{Lq}(N_0 - 1)T \end{bmatrix} + \frac{2}{N} \begin{bmatrix} i_{Ld}(N_0 + N)T \\ i_{Lq}(N_0 + NT) \end{bmatrix} \quad (21)$$

According to Fig. 7, the harmonic currents on dq frame (\tilde{i}_{Ld} , \tilde{i}_{Lq}) can be calculated from the fundamental components (from SWFA method) by using (22) and (23) as follow:

$$\tilde{i}_{Ld} = i_{Ld} - \bar{i}_{Ld} \quad (22)$$

$$\tilde{i}_{Lq} = i_{Lq} - \bar{i}_{Lq} \quad (23)$$

Step 4: Transform the harmonic currents on dq-frame (\tilde{i}_{Ld} , \tilde{i}_{Lq}) from Step 3 to $\alpha\beta$ -frame ($\tilde{i}_{L\alpha}$, $\tilde{i}_{L\beta}$) by using (4).

Step 5: Calculate the three-phase reference currents (i_{ca}^* , i_{cb}^* , i_{cc}^*) for a shunt active power filter (SAPF). The purposed reference currents can be determined from the harmonic currents on $\alpha\beta$ -frame ($\tilde{i}_{L\alpha}$, $\tilde{i}_{L\beta}$) from Step 4 and the zero current (i_{L0}) from Step 1 by using (5). The Step 4 and Step 5 of the DQF method are the same as those from SRF method.

III. PERFORMANCE INDEXES FOR THE COMPARISON OF HARMONIC DETECTION METHOD

The performance indexes for the comparison of this paper are %THD of the source current after compensation and the power factor (pf) at PCC point (source). %THD can be calculated by:

$$THD_I = \frac{1}{I_1} \sqrt{\sum_{h=2}^{\infty} I_h^2} = \sqrt{\left(\frac{I_{rms}}{I_{1,rms}}\right)^2 - 1} \quad (24)$$

and power factor at PCC point can be determined by:

$$pf = \frac{P}{S} = pf_{disp} \cdot pf_{dist} \quad (25)$$

pf_{disp} in (25) is the displacement power factor calculated by:

$$pf_{disp} = \frac{P}{S_1} \quad (26)$$

where p is the real power (W), s_1 is the apparent power at the fundamental frequency (VA).

In addition, pf_{dist} in (25) is the distortion power factor calculated by:

$$pf_{dist} = \frac{S_1}{S} = \frac{1}{\sqrt{1+THD_V^2} \cdot \sqrt{1+THD_I^2}} \quad (27)$$

where THD_V and THD_I are the total harmonic distortion of the voltage and current at the PCC point, respectively.

The %THD and the power factor value explained in this section will be used as the performance index for the comparison between three methods that are described before in Section II.

IV. SIMULATION RESULTS

The aim of this paper is to compare the different harmonic detection methods. Therefore, the structure of the active power filter is not concerned. To achieve the perfect compensation, the ideal current source is used as the active power filter for the comparison study in this paper. This is because the ideal current source can perfectly compensate the harmonic current. Due to the active power filter behaving as the ideal current source (perfectly injection), the compensating currents as shown in Fig.1 (i_{ca} , i_{cb} , i_{cc}) are equal to the reference currents (i_{ca}^* , i_{cb}^* , i_{cc}^*) under this assumption.

From Fig.1, the three-phase rectifier feeding the parallel RC loads ($R = 3.37 \text{ k}\Omega$ and $C = 4.7 \text{ }\mu\text{F}$) behaves as a nonlinear load to the power system. For the comparison, the SRF, SD, and DQF methods are used as the harmonic detection block as shown in Fig.1. The compensating currents directly inject via the ideal active power filter at $t = 0.04 \text{ s}$. All compensating currents are determined from the reference currents calculated from the three harmonic detection methods. The results of the compensated currents for phase a using the different harmonic detection methods, here are SRF, SD, and DQF are illustrated in Fig.8 to Fig.10, respectively. From Fig.8 to Fig.10, it can be seen that the source current (i_{sa}) is equal to the load current (i_{La}) before compensation time ($t < 0.04 \text{ s}$). In addition, in Fig.10, the DQF method needs the time for calculating the initial value during the first period ($t = 0.04\text{-}0.06 \text{ s}$). In Table I, the %THD of uncompensated current is 71.01%. This value is extremely greater than the IEEE std.519-1992 and the pf before compensation is equal to 0.77. Note that the pf value can be calculated from pf_{disp} and pf_{dist} by using (25). After compensation, the source currents are nearly the sinusoidal waveform. As a result, the %THD of the source currents after compensation is decreased. However, it can be seen from Fig.8 to Fig.10 that it is very difficult to compare the results from the different harmonic detection techniques. Therefore, the source current waveforms after compensation from the different harmonic detection methods are used to calculate the performance index as mentioned before in Section III. The comparison results are given in Table I. From the comparison results, it can be summarized that the DQF method can provide the best result in terms of %THD (0.003%) compared with others. However, the pf value at PCC point after compensation when we use the DQF method ($pf = 0.96$) is slightly less than the SD method ($pf = 1$). In the future, the authors will improve the DQF method to achieve the unity power factor at the PCC point, while the %THD after compensation still be the best compared with other harmonic detection methods.

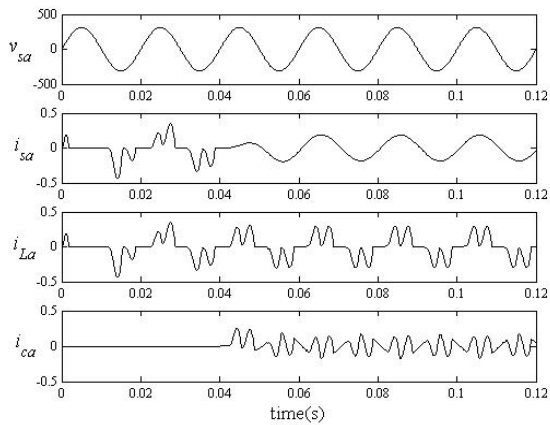

Fig. 8 The results of the SRF method

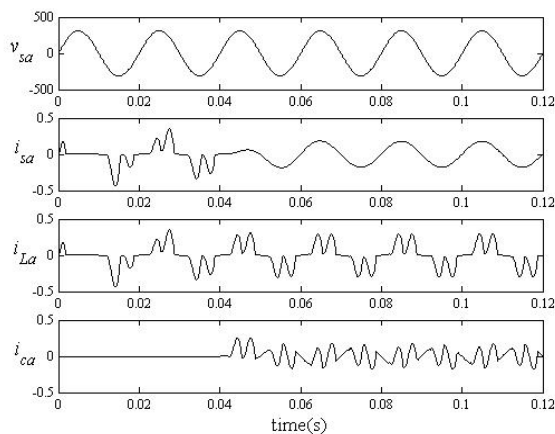

Fig. 9 The results of the SD method

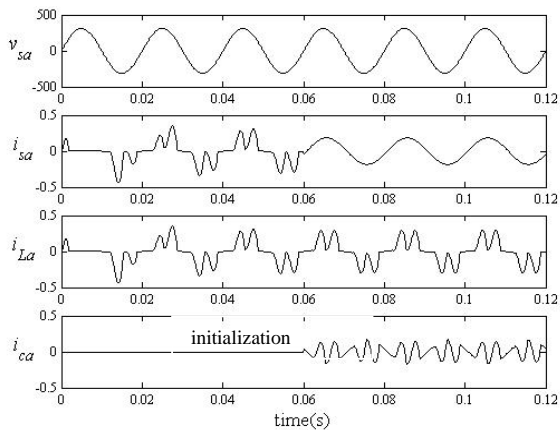

Fig.10 The results of the DQF method

TABLE I
THE COMPARISON RESULTS OF THE VARIOUS HARMONIC DETECTION METHODS

Harmonic Detection Method	%THD (i_{sa})	Power Factor		
		Pf_{disp}	Pf_{dist}	Pf
Before Compensation				
SRF	71.01%	0.96	0.81	0.77
SD				
DQF				
After Compensation				
SRF	0.42%	0.96	1	0.96
SD	0.41%	1	1	1
DQF	0.003%	0.96	1	0.96

V. CONCLUSION

This paper presents the comparison study of the various harmonic detection methods called SRF, SD and DQF methods. The %THD and the power factor value at the PCC point are used as the performance indexes for the comparison. The ideal active power filter is used with the harmonic detection method for the comparison study. The results show that the DQF method provides the minimum %THD after compensation compared with other methods. However, the power factor value at the PCC point after compensation is slightly lower than that of the SD method. In the future, the authors will improve the DQF method to achieve the unity power factor at the PCC point, while the %THD after compensation still be the best compared with other harmonic detection methods.

ACKNOWLEDGMENT

The author would like to thank Mr. Tosaporn Narongrit for his valuable discussions and Suranaree University of Technology for financial support.

REFERENCES

- [1] IEEE Std. 519-1992 ,IEEE Recommended practices and requirement for harmonic control in electrical power system.
- [2] F. Zhuo , J. Yang, J. Hu, and Z. Wang, "Study on Active Power Filter used in Three-Phase Four Wire System", *IEEE Power Electronics and Motion Control Conference*, vol.3, 2000, pp. 1037-1040.
- [3] M. Takeda, K. Ikeda, A. Teramoto and T. Aritsuka, "Harmonic Current and Reactive Power Compensation with an Active Filter," *IEEE Conference on Power Electronics Specialists (PESC '88)*, 1988, pp. 1174-1179.
- [4] C.L. Chen, C.E. Lin, and C.L. Huang, "An Active Filter for Unbalanced Three-Phase System Using Synchronous Detection Method," *IEEE Conference on Power Electronics Specialists (PESC '94)*, 1994, pp. 1451-1455.
- [5] S. Sujitjorn, K-L. Areerak, and T. Kulworawanichpong, "The DQ Axis With Fourier (DQF) Method for Harmonic Identification," *IEEE Transactions on Power Delivery*, 2007, pp. 737-739.
- [6] P. Santiprapan and K-L. Areerak, "Performance Improvement of Harmonic Detection using Synchronous Reference Frame Method", *2010 International Conference on Advances in Energy Engineering (ICAEE 2010)*, Beijing, China, 19-20 June 2010, pp. 52-55.
- [7] M. El-Habrouk, and M. K. Darwish, "Design and Implementation of a Modified Fourier Analysis Harmonic Current Computation Technique for Power Active Filter Using DSPs," *IEE Proc.-Electr. Power Appl*, 2001, pp. 21-28.