

System Reliability by Prediction of Generator Output and Losses in a Competitive Energy Market

Perumal Nallagownden, Ravindra N. Mukerjee, and Syafrudin Masri

Abstract—In a competitive energy market, system reliability should be maintained at all times. Power system operation being of online in nature, the energy balance requirements must be satisfied to ensure reliable operation the system. To achieve this, information regarding the expected status of the system, the scheduled transactions and the relevant inputs necessary to make either a transaction contract or a transmission contract operational, have to be made available in real time. The real time procedure proposed, facilitates this. This paper proposes a quadratic curve learning procedure, which enables a generator's contribution to the retailer demand, power loss of transaction in a line at the retail end and its associated losses for an oncoming operating scenario to be predicted. Matlab program was used to test in on a 24-bus IEE Reliability Test System, and the results are found to be acceptable.

Keywords—Deregulation, learning coefficients, reliability, prediction, competitive energy market.

I. INTRODUCTION

IN a competitive energy market consisting of a number of generation providers, a number of transmission system operators (TSO), a number of retailers who serve the customers, and also an independent system operator (ISO) overseeing coordinated operation between these elements and carrying out arbitration when required, system stability and reliability are being increasingly perceived as important criteria for the smooth transition of the energy market from regulated to deregulated operation.

The reliable operation of power system must satisfy the energy balance requirements in real-time periods. A feasible operating system is one in which the level of supply and demand lies within the limits of the system capabilities. [1].

The operation of power system involves transmission losses which are unique to location and depends on the system state, or current operating point and cannot be forecast precisely. Load varies in a stochastic manner and cannot be estimated accurately. Information regarding the expected status of the system and the scheduled transactions are necessary to system

reliability and stability.

It is required to predict generations participating in meeting a retailer's future demand, predict capacity utilization of the generation providers involved in meeting a demand and capacity utilization of alternate bulk transmission paths supplying this future demand, to achieve this, the paper proposes a quadratic curve learning procedure, which enables learning of the relationship between a demand and the contributions to this demand through each possible flow path at both ends of the path. The procedure further enables the learning of the relationship between a line flow and a generation's contribution to this flow. Based on the current and few past operational scenarios, once these learning factors are obtained, they can be used to predict contribution of each generation to a future retailer demand, contribution of each line at its both ends to a future retailer demand and contribution from each generation to a line flow corresponding to a future retailer demand. By predicting the flows at both ends of a line to meet a retailer demand, it's possible to predict the power loss in a line for carrying a certain portion of a retailer's future demand. The learning coefficient can be kept updated, as and when new operational scenarios come up.

II. APPROACH AND METHODS

A. Tracing Power Flow Review Stage

Transmission loss in a line depends on power flow through it, and power flow in any line is additive over supplies from generators connected to the line. Thus, portion of the transmission loss attributed to a generator depends on the way its power flow shares the lines in the network with the supplies from other generators [2].

The large transmission network provides large number of possible routes for electricity to flow. Tracing the flow of electricity using conventional load flow is impossible due to the changing demand which will affect the operation of the systems.

The proposed electricity tracing can only be applied to a system if Kirchoff Current Law is satisfied in all the nodes. The tracing principle works on the proportional sharing principle.

Perumal is with the Electrical and Electronic Engineering Department, University Technology Petronas, Perak. Malaysia (phone: 605 3687820; fax: 605 3657443; e-mail: perumal@petronas.com.my).

Ravindra N. Mukerjee is with the Department of Energy Technology, Alburg University, Denmark (e-mail: rnm@iet.aau.dk).

Syafruddin Masri is with the Electrical Engineering Department University sains Malaysia, Penang. Malaysia (e-mail: syaf@org.usm.my).

B. Tracing Generator Power Flow

P_i , the outflow to the i^{th} bus, is the sum of all the outflows through the lines connected to the bus and the local bus load

$$P_i = \left(\sum_{l \in \mu} |P_{l-i}| \right) + P_{Li} \quad \text{for } i=1,2,\dots,n \quad (1)$$

Where μ is the set of nodes directly supplied from node i , implying power flow from i^{th} node. If the line losses are neglected, then $|P_{l-i}| = |P_{i-l}|$. Equation (1) can be further expanded into:

$$P_i = \left(\sum_{l \in \mu} \left| \frac{P_{l-i}}{P_{li}} P_l \right| \right) + P_{Li} \quad \text{for } i=1,2,\dots,n \quad (2)$$

Defining $c_{li} = \frac{|P_{l-i}|}{P_l}$ expressing relationship between line flow and the nodal flow at the l^{th} node and using proportional sharing principle, $|P_{l-i}| = c_{li} P_l$.

Substituting this in (2) yields $\left(P_i - \sum_{l \in \mu} c_{li} P_l \right) = P_{Li}$ or $A_d P = P_L$.

P is the vector of net nodal powers. P_{Li} is the vector of nodal load demands. By applying this formula to a 4 bus system, the formula $A_d P = P_L$ can be expanded as shown below:

In order to generalize the elements of A_d , it is important to recall equation $c_{li} = \frac{|P_{l-i}|}{P_l}$.

For the diagonal element c_{11} , c_{22} , c_{33} and c_{44} the values will always equal to 1 because $c_{ll} = \frac{|P_{l-l}|}{P_l} = \frac{P_l}{P_l} = 1$.

For the off diagonal element it is important to know whether there is any connection between 2 buses.

If there is any connection between the buses, then $c_{li} = \frac{|P_{l-i}|}{P_l}$ or else $c_{li} = 0$. The elements of A_d matrix can be summarize:

$$[A_d]_{il} = \begin{cases} 1 & \text{for } i = j \\ -c_{li} = -\frac{|P_{l-i}|}{P_l} & \text{for } j \in \mu \\ 0 & \text{otherwise} \end{cases} \quad (3)$$

The i^{th} element of $P = A_d^{-1} P_L$ shows the distribution of the i^{th} nodal power between all the loads in the system. The i^{th} element of the equation is given by:

$$P_i = \sum_{k=1}^n [A_d^{-1}]_{ik} P_{Lk} \quad \text{for } i=1,2,\dots,n \quad (4)$$

Nodal generation also an inflow at the i^{th} bus is given by:

$$P_{Gi} = \frac{P_{Gi}}{P_i} P_i \quad \text{or} \quad P_{Gi} = \left(\frac{P_{Gi}}{P_i} \sum_{k=1}^n [A_d^{-1}]_{ik} \right) P_{Lk} \quad (5)$$

from $i=1,2,\dots,n$

Equation (5) shows share of the output of the i^{th} generator used to supply the k^{th} load demand. It can be used to trace where the power of a generator goes to.

C. Tracing Power Flow from a Load

P_i , the inflow to the i^{th} bus, is the sum of all the inflows through the lines connected to the bus and the local bus injection

$$P_i = \left(\sum_{j \in \eta} |P_{i-j}| \right) + P_{Gi} \quad \text{for } i=1,2,\dots,n \quad (6)$$

Where η is the set of nodes directly supplying node i , implying power flow towards i^{th} node. If the line losses are neglected, then $|P_{j-i}| = |P_{i-j}|$. Equation (6) can be further expanded to become:

$$P_i = \left(\sum_{j \in \eta} \left| \frac{P_{j-i}}{P_j} P_j \right| \right) + P_{Gi} \quad \text{for } i=1,2,\dots,n \quad (7)$$

By defining $c_{ji} = \frac{|P_{j-i}|}{P_j}$ expressing relationship between

line flow and the nodal flow at the j^{th} node, using proportional sharing principle $|P_{j-i}| = c_{ji} P_j$, substituting this in

(7) yields $\left(P_i - \sum_{j \in \eta} c_{ji} P_j \right) = P_{Gi}$ or $A_u P = P_G$, P is the vector of gross nodal flows.

Gross nodal flow is the sum of the actual demand and the allocated part of the losses to the demand. P_G is the vector of nodal generations.

By using the same 4 bus system that was applied at the earlier section, the equation $A_u P = P_G$ can be further expanded as shown below:

In order to generalize the elements of A_u , it is important to recall equation $c_{ji} = \frac{|P_{j-i}|}{P_j}$.

For the diagonal element c_{11} , c_{22} , c_{33} and c_{44} the values will always equal to 1 because $c_{jj} = \frac{|P_{j-j}|}{P_j} = \frac{P_j}{P_j} = 1$.

For the off diagonal element it is important to know whether there is any connection between 2 buses. If there is any connection between the buses, then $c_{ji} = \frac{|P_{j-i}|}{P_j}$ or else $c_{ji} = 0$. The elements of A_u matrix can be summarized:

$$[A_u]_{ij} = \begin{cases} 1 & \text{for } i = j \\ -c_{ji} = -\frac{|P_{j-i}|}{P_j} & \text{for } j \in \eta \\ 0 & \text{otherwise} \end{cases} \quad (8)$$

The i^{th} element of $P = A_u^{-1}P_G$ shows the participation of the k^{th} generation to the i^{th} nodal flow and determines the relative participation of the nodal generations in meeting a retailer's demand and is given by

$$P_i = \sum_{k=1}^n [A_u^{-1}]_{ik} P_{Gk} \quad \text{for } i=1,2,\dots,n \quad (9)$$

Load demand at the i^{th} bus is given by

$$P_{Li} = \frac{P_{Li}}{P_i} P_i \quad \text{or} \quad P_{Li} = \left(\frac{P_{Li}}{P_i} \sum_{k=1}^n [A_d^{-1}]_{ik} \right) P_{Gk} \quad (10)$$

from $i = 1, 2, \dots, n$

Equation (10) shows contribution of the k^{th} generator to the i^{th} load demand. It can be used to trace where the power of a specific load comes from.

D. Share of a Transaction in a Line-Flow

A line outflow in line $i - \ell$ from node i , using the proportional sharing principle and using equation (10) can be given by:

$$|P_{i-\ell}| = \frac{|P_{i-\ell}|}{P_i} P_i = \frac{|P_{i-\ell}|}{P_i} \sum_{k=1}^n [A_d^{-1}]_{ik} P_{Gk} \quad (11)$$

Where $D_{i-\ell,k}^G = \frac{|P_{i-\ell}|}{P_i} [A_u^{-1}]_{ik}$ with $i \in \mu$ the set of nodes supplied directly from node i , are the topological distribution

factors and give the share of the k^{th} generation in the total line flow in line $i - \ell$.

Inflow to node i from line $i - j$ is calculated using the proportional sharing principle as

$$|P_{i-j}| = \frac{|P_{i-j}|}{P_i} P_i = \frac{|P_{i-j}|}{P_i} \sum_{k=1}^n [A_d^{-1}]_{ik} P_{Lk} \quad (12)$$

$$P_{Lk} = \sum_{k=1}^n D_{i-j,k}^L P_{Lk} \quad \text{for all } j \in \eta$$

Where $D_{i-j,k}^L = \frac{|P_{i-j}|}{P_i} [A_d^{-1}]_{ik}$ is the topological load distribution factor giving portion of the k^{th} load demand that flows in line. $i - j$

$$\text{Using} \quad D_{i-j,k}^G = \frac{|P_{i-j}|}{P_i} [A_u^{-1}]_{ik} P_{Gk} \quad \text{and}$$

$D_{i-j,m}^L = \frac{|P_{i-j}|}{P_i} [A_d^{-1}]_{im} P_{Lm}$ a part of a specific transaction between k^{th} generation provider and the m^{th} retailer using a transmission circuit $i - j$ can be determined.

III. PREDICTING FUTURE DEMAND

Generalized quadratic relationships between (i) a retailers demand and share of generations meeting this demand, (ii) a retailers demand and the power loss in a transaction, (iii) a retailers demand and the share of the part of the transactions in a line and (iv) a retailer's demand and the losses pertaining to each of the transactions in a line, are proposed, to facilitate the generation of these learning coefficients. Four types of learning coefficients $(\alpha_1, \beta_1, \gamma_1)$, $(\alpha_2, \beta_2, \gamma_2)$, $(\alpha_3, \beta_3, \gamma_3)$ and $(\alpha_4, \beta_4, \gamma_4)$ need to be generated at each demand node of the network. Thus, there will be $(ng \times npq)$ sets of $(\alpha_1, \beta_1, \gamma_1)$, $(ng \times npq)$ sets of $(\alpha_2, \beta_2, \gamma_2)$, $(ng \times npq \times n\ell)$ sets of $(\alpha_3, \beta_3, \gamma_3)$ and $(ng \times npq \times n\ell)$ sets of $(\alpha_4, \beta_4, \gamma_4)$ to be generated using real time operating scenarios, during learning exercise. 'ng' represents number of generations. (npq) represents number of retail or demand points and 'nl' represents number of active links in an operating scenario.

A. Learning Relationship between a Generator's Contribution to a Retailers Demand at the Receiving End

$$\frac{\alpha_1}{P_d} + \beta_1 + \gamma_1 P_d = P_{gd} \quad (13)$$

Where P_d is the total demand at a retailer's point of receipt

in per unit (p.u.), P_{gd} = a generator's contribution to a retailers demand at the point of receipt in p.u.

B. Learning Relationship between a Retailer's Demand and the Associated Loss in a Transaction

$$\frac{\alpha_2}{P_d} + \beta_2 + \gamma_2 P_d = Loss_t \tag{14}$$

Where P_d = the total demand at a retailer's point of receipt in p.u., $Loss_t$ = loss in a transaction in p.u. (The difference between a generation's contribution to a demand at the generation end and a generation's contribution to a demand at the load bus).

C. Learning Relationship between a Retailer's Demand and the Share of Transactions in a Line at a Point of Receipt

$$\frac{\alpha_3}{P_d} + \beta_3 + \gamma_3 P_d = P_{ld} \tag{15}$$

Where P_d = the total demand at a retailer's point of receipt p.u., P_{ld} = the share of transactions in a line at a point of receipt in p.u.

D. Learning Relationship between a Retailer's Demand and the Line Losses in Each Line Used by a Transaction

$$\frac{\alpha_4}{P_d} + \beta_4 + \gamma_4 P_d = Loss_{ld} \tag{16}$$

Where P_d = the total demand at a retailer's point of receipt in p.u., $Loss_{ld}$ = losses for each of the transactions in a line in p.u.

presented in Table I. The predicted values of upstream trace and the loss associated with a transmission for oncoming operating scenario are also shown in the table.

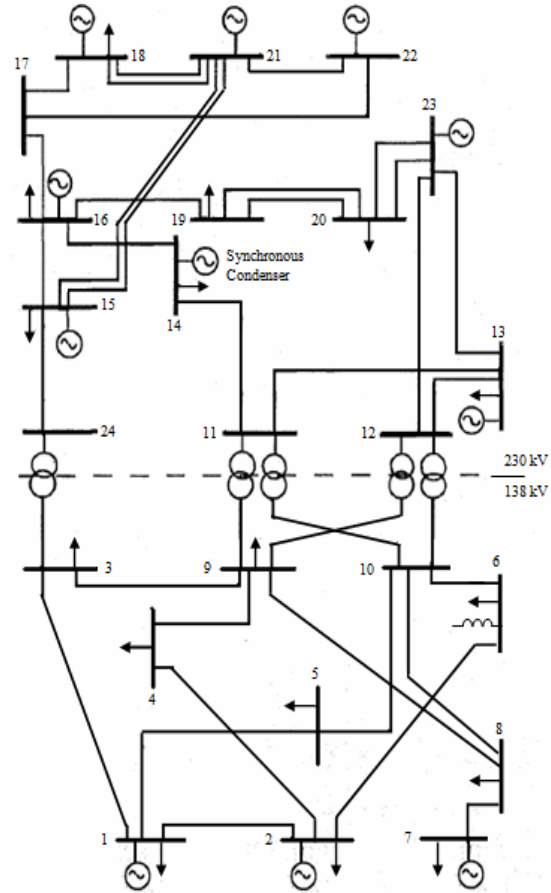

Fig. 1 24-Bus IEEE Test System

IV. RESULTS

The simulation was done on a 6-bus and a 24-bus IEEE Reliability test system shown in Fig. 1. The different transactions required and their associated losses for 4 different values of retailer's demand for a 24-bus system are

TABLE I
24-BUS IEEE RELIABILITY TEST SYSTEM
DOWNSTREAM TRACE (GENERATION END) & UPSTREAM TRACE (RETAIL END) LOAD AT BUS 4 FOR CURRENT AND ONCOMING SCENARIO

	Generator	Actual value									Actual value			Predicted value		
		Load = 0.77 p.u.			Load = 0.7 p.u.			Load = 0.63 p.u.			Load = 0.84 p.u.			Load = 0.84 p.u.		
		Gen	Retail	Loss	Gen	Retail	Loss	Gen	Retail	Loss	Gen	Retail	Loss	Gen	Retail	Loss
Bus 4		End	End		End	End		End	End		End	End		End	End	
	1	0.0499	0.0491	0.0008	0.0404	0.0398	0.0006	0.0327	0.0323	0.0004	0.0593	0.0583	0.001	0.06	0.0599	1E-04
	2	0.3271	0.322	0.005	0.3081	0.3038	0.0044	0.2914	0.2875	0.0039	0.3439	0.3382	0.0057	0.3528	0.3468	0.006
	13	0.0489	0.048	0.0009	0.0467	0.0459	0.0008	0.0437	0.043	0.0007	0.0497	0.0487	0.001	0.0593	0.0496	0.0097
	16	0.0085	0.0081	0.0003	0.0073	0.0071	0.0003	0.0085	0.0064	0.0021	0.0095	0.0091	0.0004	0.0098	0.0095	0.0003
	18	0.0108	0.0103	0.0005	0.0094	0.0089	0.0004	0.0081	0.0077	0.0004	0.0121	0.0115	0.0006	0.0123	0.0117	0.0006
	21	0.0322	0.0303	0.0019	0.0276	0.0261	0.0016	0.0238	0.0225	0.0013	0.0364	0.0343	0.0022	0.0372	0.035	0.0022
	22	0.0357	0.0334	0.0023	0.0308	0.0289	0.002	0.0267	0.025	0.0017	0.0402	0.0375	0.0027	0.0411	0.0384	0.0027
23	0.2893	0.2771	0.0122	0.2522	0.2419	0.0103	0.2199	0.2111	0.0088	0.3228	0.3087	0.0141	0.33	0.3156	0.0144	

V. CONCLUSION

The paper extends the power tracing method proposed in [2,7] to come out with a methodology which, based on the current and past operating scenarios, could help in learning the relationships between a retailer's demand and (i) a path through learning coefficients. These learning coefficients can be stored in the computer memory.

Through the related learning coefficients, for an oncoming transaction it is possible to predict a generation's participation to a retailer's likely demand, losses associated with this likely transaction, share of the likely transaction in a line at the retailer's end and also the share of losses in a line associated with a likely transaction. The results obtained confirm the accuracy of the method proposed.

REFERENCES

- [1] Fernando.L, Alvarado, Robert J camfield, Rajesh Rajaraman. Proc. 30th Hawaii International Conference on System Sciences: Advanced Technology Track - Volume 5. pg 571.
- [2] Bialek JW, P.A.Kattuman, Abi Samra.N, Electricity Tracing and Co-operative Game theory. Proc. 13th power System computation Conference. June 28-July 2. 1999.pp 238-243.
- [3] Strbac G, Kirschen D, Ahmed S. Allocating Transmission System Usage on the Basis of Traceable Contributions of Generators and Loads to Flows. IEEE Transactions on Power Systems, 1998; 13 (2): 527-534.
- [4] Bialek J. Identification of Source-Sink Connections in transmission Networks. Proceedings of Power systems Control and Management, 1996; pp. 200-204.
- [5] Bialek J. Tracing the Flow of Electricity. IEE proc. Gener. Trans. Distrib, 1996; 143 (4): 313-320.
- [6] Kirschen D, Allan R, Strbac G. Contribution of Individual Generators to Loads and Flows. IEEE Transactions on Power Systems, 1997; 12 (1): 52-60.
- [7] Bialek JW, Ziemianek S, Wallace R. A Methodology for Allocating Transmission Losses Due to Cross-Border Trades. IEEE Transaction on Power systems, 2004; 19 (3): 1255-1262.C. J. Kaufman, Rocky Mountain Research Lab., Boulder, CO, private communication, May 1995.
- [8] Bialek JW, Kattuman PA. Proportional sharing assumption in Tracing Methodology. IEE Proc. Gener. Transm. Distrib, 2004; 151 (4): 526-532.
- [9] Sabastian P.Rosada, Nouredine Hadj Said. Tracing the Path of Electric Power Flow – A Study for Deregulated Power Systems.