

Friction Stir Welding Process: A Green Technology

Esther T. Akinlabi, and Stephen A. Akinlabi

Abstract—Friction Stir Welding (FSW) is a solid state welding process invented and patented by The Welding Institute (TWI) in the United Kingdom in 1991 for butt and lap welding of metals and plastics. This paper highlights the benefits of friction stir welding process as an energy efficient and a green technology process in the field of welding. Compared to the other conventional welding processes, its benefits, typical applications and its use in joining similar and dissimilar materials are also presented.

Keywords—Dissimilar materials, Friction Stir Welding, Green technology, similar materials.

I. INTRODUCTION

FRICITION Stir Welding (FSW) is considered to be the most significant development in joining over the past two decades. FSW was invented and validated by Dr Wayne Thomas and his team in 1991 at The Welding Institute (TWI), of the United Kingdom, as a solid-state joining technique. FSW has become increasingly popular in applications in aviation, manufacturing, electrical and automobile industries owing to the energy efficiency, the environmental friendliness and versatility of the FSW technique [1]. The number of applications is anticipated to grow exponentially as fabricators learn of the ease of application and property benefits attributed to FSW. The FSW process is remarkably simple but however involves thermal and material flow dynamics. Many weld configurations are achievable using the FSW process. The FSW process involves plunging a non-consumable tool between the abutting edges of the two plates to be butt-welded, traversing the tool along the joint line (at a predetermined rotational speed and feed rate), and at the end, the tool is retracted from the weld. The fundamental difference between conventional welding techniques and the solid-state Friction Stir Welding (FSW) technique is that no heat is added to the 'system'; instead heat is generated internally by means of friction between the tool-material interface resulting in the plastic deformation of the material around the stir zone.

The tool is the fundamental component of Friction Stir Welding (FSW) and has evolved empirically based on observations of forces, weld defects, rotational speeds, transverse speeds and material flow [2]. Tool attributes that

could alter the characteristics of a FSW joint are the shoulder diameter and the pin size (length, thickness and shape). Since its invention, the process has been continually improved and its scope of application expanded. The relative motion between the tool and the substrate generates frictional heat that creates a plasticised region around the immersed portion of the tool and the tool shoulder prevents the plasticised material from being expelled from the weld, forcing the plasticised material to coalesce behind the tool to form a solid-phase joint. A schematic of the process is presented in Fig. 1.

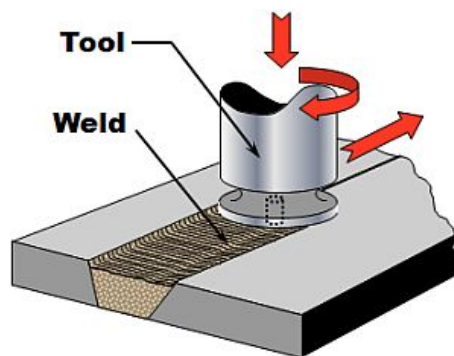

Fig. 1 Schematic diagram of the Friction Stir welding Process [3]

TABLE I
BENEFITS OF THE FSW PROCESS [4]

Metallurgical benefits	Environmental benefits	Energy benefits
1. Solid-phase process.	1. No shielding gas required for materials with low melting temperature.	1. Improved materials use (e.g. joining different thickness) allows reduction in weight.
2. Low distortion.	2. Minimal surface cleaning required.	2. Only 2.5% of the energy needed for a laser weld.
3. Good dimensional stability and repeatability.	3. Eliminates grinding wastes.	3. Decreased fuel consumption in lightweight aircraft, automotive, and ship applications.
4. No loss of alloying elements.	4. Eliminates solvents required for degreasing.	
5. Excellent mechanical properties in the joint area.	5. Consumable materials saving.	
6. Fine recrystallized microstructure.	6. No harmful emissions.	
7. Absence of solidification cracking.		
8. Replaces multiple parts joined by fasteners.		

Friction Stir Welding (FSW) can be considered as a green technology because no gases are evolved during the process. Also, there are no toxic fumes or smoke produced during or

E. T. Akinlabi is a lecturer in the Department of Mechanical Engineering Science, University of Johannesburg, Auckland Park, Johannesburg, South Africa, 2006. (Phone: +2711-559-2137; e-mail: etakinlabi@uj.ac.za).

S. A. Akinlabi is a doctorate candidate in the Department of Mechanical Engineering Science, University of Johannesburg, South Africa, 2006. (Phone: +277984-77095; e-mail: saakinlabi@uj.ac.za).

after the welding process. The process is energy efficient and environmentally friendly. Compared to other conventional fusion welding methods, FSW offers a number of advantages: the benefits of the process in respect of metallurgy, the environment and energy saving are presented in Table I.

II. TYPICAL APPLICATIONS OF FRICTION STIR WELDING

FSW is becoming the choice of many industries for structurally demanding applications, because the process is devoid of severe distortion. Currently, FSW is being used for joining similar and dissimilar alloys in ship building, marine industries, aerospace, rail industries, container and fuel tank industries. The replacement of fastened joints with friction stir welded lap joints has been observed to lead to significant weight reduction and cost savings for many industries and the weight savings can be achieved as a result of the elimination of the fasteners. The cost savings can be realised by a decrease in design, manufacturing, assembly and maintenance times, and improved corrosion performance by eliminating the fasteners as a source of dissimilar metal contact [6]. Furthermore, the technology provides significant advantage to the aluminium industry; and automotive suppliers are already using the technique for wheel rims and suspension arms. The railway industry is also not left out of the loop with the rapid development of high-speed rail cars. The FSW process has been used to manufacture high quality joints in the rail car body, window, side wall and coupling gears [7]. The use of robot in FSW is also becoming popular. Typical applications of the FSW process are presented in Table II.

TABLE II
TYPICAL APPLICATIONS OF FSW [PARTIALLY ADAPTED FROM SMITH ET AL]

Industry category	Specific applications	Present process	Advantages of using FSW
Electrical	Heat sinks – welded laminations	Gas Metal Arc Welding (GMAW)	Higher density of fins – better conductivity.
Electrical	Cabinets and enclosures	GMAW	Reduced cost, weld through corrosion coatings.
Batteries	Leads	Solder	Higher quality.
Military	Shipping pallets	GMAW	Reduced cost
Extrusions	Customized extrusions	Not done today	Can be customized to reduce need for large presses.
Boats and ship building	Keel, tanks and the hull	Rivets and GMAW	Stronger, Less Distortion
Golf Cars, Snowmobiles	Chassis, Suspension	GMAW	Less distortion, better fatigue life properties.
Tanks, Cylinders	Fittings, Long & Circumferential Seams	GMAW	Higher quality - less leaks, higher uptime.
Aerospace	Floors, wing and fuselage.	Rivets	Higher quality, cheaper (no rivets and holes).
Automotive	wheel rims and suspension arms	GMAW, MIG	Better joint integrity.
Rail industry	Rail car body, window, side wall and coupling gears	GMAC	High quality joints

The next section in this paper highlights some successful joining of similar materials using the FSW process.

III. FRICTION STIR WELDING OF SIMILAR MATERIALS

FSW has been successfully used to weld similar materials. Research studies conducted on friction stir butt welds of similar aluminium alloys have been reported by many researchers [8-10] in which process windows were successfully established and being applied in the industry. Similar copper plates have also been friction stir welded by Sun and Fujii; and Hwang *et al* [11], the appropriate processing parameters and temperature for joining copper plates were also achieved. Magnesium plates had also been joined using friction stir welding by Suhuddin *et al* [12], good quality welds were produced and it was concluded that FSW has a very good potential for the joining of magnesium and its alloys. The next section of this paper focuses on the application of FSW in joining dissimilar materials

IV. FRICTION STIR WELDING OF DISSIMILAR MATERIALS

Research studies on dissimilar metal friction stir welds are hereby highlighted and presented. Yoshikawa [13] established a joining criterion for lap welding of dissimilar aluminium and stainless steel and Fukumoto *et al* [14] achieved good weld joint efficiency in dissimilar joints between normal carbon steel (S45C) and 6063 aluminium alloy. Other successful dissimilar joining using the FSW process include Aluminium and Brass by Esmaeili *et al* [15], Aluminium and Titanium by Wei *et al* [16]; Aluminium and Magnesium by Yan *et al* [17] and Magnesium and Titanium by Aonuma and Nakata [18]. Successful welds of aluminium and copper with good joint integrities have also been reported by Akinlabi [19]. These studies revealed that a lot of potential exists to successfully join dissimilar materials using the FSW process.

V. CONCLUSION

Friction stir welding process as a green technology has been reviewed, analysed and presented. The metallurgical, environmental and energy benefits of the process compared to the conventional arc welding processes had also been presented. The process is increasingly becoming popular and is being embraced by many industries. It can be concluded that FSW is a green technology.

ACKNOWLEDGMENT

The current research work on friction stir welding of aluminium and copper is being supported by the Tertiary Education Support Program of ESKOM and South Africa. The financial support of the University of Johannesburg Research fund is also acknowledged.

REFERENCES

- [1] Thomas WM, Nicholas ED, Needham JC, Murch MG, Templesmith P & Dawes CJ. (1991). Improvements relating to Friction Welding. International Patent Application. PCT/GB92/02203 (Patent).

- [2] Akinlabi E (2011). Characterisation of dissimilar friction stir welds between aluminium and copper. Lambert Academic Publishing, Germany. ISBN 978-3-8443-9042-1. p. 12-17
- [3] Friction stirs welding process. www.engineering.und.edu/research/aemc/fswprocess.php Assessed on 8th June 2012.
- [4] Mishra RS & Mahoney MW. Introduction. In: Friction stir welding and processing. Mishra RS, Mahoney MW (ed.) Materials Park Ohio: ASM International; 2007.
- [5] Smith CB, Hinrichs JF & Ruehl PC (2012). Friction Stir and Friction Stir Spot Welding - Lean, Mean and Green. Available online from: www.frictionstirlink/Pub14AwssmcLeanMeanGreen-UnitedStates accessed on 30th July 2012.
- [6] Khaled T. An outsider looks at Friction stir welding. Federal Aviation Administration. Report number: ANM-112N-05-06, 2005.
- [7] Friction Stir Welding Products for industrial Applications. Available from: www.cfswt.com/en/uploadpic/2010102216396671.pdf accessed on 30th July 2012.
- [8] Lakshminarayanan A K, Malarvizhi, S & Balasubramanian V (2011). Developing friction stir welding window for AA2219 aluminium alloy. Transactions of Nonferrous Metals Society of China. 21, 2339-2347.
- [9] Xu WF, Liu JH, Chen DL, Luan GH and Yao JS (2012). Improvements of strength and ductility in aluminium alloy joints via rapid cooling during friction stir welding. Materials Science and Engineering A. 548, 89-98.
- [10] Zhang G, Su W, Zhang J, Wei Z and Zhang J (2010). Effects of shoulder on interfacial bonding during friction stir lap welding of aluminium thin sheets using tool without pin. Transactions of Nonferrous Metals Society of China. 20, 2223-2228.
- [11] Hwang YM, Fan PL & Lin CH (2010). Experimental study on Friction Stir Welding of copper metals. Journal of Material Processing Technology. 210, 1667-1672.
- [12] Suhuddin UFHR, Mironov S, Sato YS, Kokawa H & Lee CW (2009). Grain structure evolution during friction-stir welding of AZ31 magnesium alloy. Acta Materialia. 57, 5406-5418.
- [13] Yoshikawa K (2003). A joining criterion for lap welding of dissimilar metal materials of aluminium and stainless steel. 4th International FSW symposium, Park City, Utah. 14-16. TWI (UK). Retrieved: CD-ROM.
- [14] Fukumoto M, Yasui T, Shinoda Y, Tshubaki M & Shinoda T (2004). Butt welding between dissimilar metals by friction stirring. 5th International FSW symposium, Metz, France. 14-16. TWI (UK). Retrieved: CD-ROM.
- [15] Esmaeili A, Besharati Givi MK & Zareie Rajani HR (2011). A metallurgical and mechanical study on dissimilar Friction Stir welding of aluminium 1050 to brass (CuZn30). Materials Science and Engineering A. 528, 7093-7102.
- [16] Wei Y, Li J, Xiong J, Huang F Zhang F and Raza SH (2012). Joining aluminium to titanium alloy by friction stir lap welding with cutting pin. Journal of Material Characterization. 71, 1-5.
- [17] Yan Y, Zhang D, Qiu C & Zhang W (2010). Dissimilar frictions stir welding between 5052 aluminium alloy and AZ31 magnesium alloy. Transactions of Nonferrous Metals Society of China. 20, 619-623.
- [18] Aonuma M & Nakata K (2012). Journal of Materials Science and Engineering B. 177, 543-548.
- [19] Akinlabi ET (2012). Effect of shoulder size on weld properties of dissimilar metal friction stir welds. Journal of Materials Engineering Performance. DOI: 10.1007/s11665-011-0046-6. 21, 1514-1519.