

Evaluation of the Displacement-Based and the Force-Based Adaptive Pushover Methods in Seismic Response Estimation of Irregular Buildings Considering Torsional Effects

R. Abbasnia, F. Mohajeri Nav, S. Zahedifar, and A. Tajik

Abstract— Recent years, adaptive pushover methods have been developed for seismic analysis of structures. Herein, the accuracy of the displacement-based adaptive pushover (DAP) method, which is introduced by Antoniou and Pinho [2004], is evaluated for Irregular buildings. The results are compared to the force-based procedure. Both concrete and steel frame structures, asymmetric in plan and elevation are analyzed and also torsional effects are taking into the account. These analyses are performed using both near fault and far fault records. In order to verify the results, the Incremental Dynamic Analysis (IDA) is performed.

Keywords— Pushover Analysis, DAP, IDA, Torsion.

I. INTRODUCTION

A main challenge in performance-based design is to develop simple but accurate methods for estimating the seismic response of structures. In comparison with time-consuming and complex methods such as Incremental Dynamic Analysis (IDA), non-linear static (pushover) analyses are more practical and simple. Hence, pushover procedures have been extensively developed during the last decade.

Conventional pushover procedures, such as the Capacity Spectrum Method [1] and The Displacement Coefficient Method [2], only consider the dominant mode of structure. Hence, these methods rely on a pushover analysis using invariant lateral load patterns to estimate deformation demands under seismic loading. Based on these assumptions, conventional pushover methods are known to have major drawbacks [3].

In order to solve the problems of conventional methods, several researchers have proposed advanced pushover procedures [4], [5], [6]. Some advanced methods, such as MPA [4], retain the simplicity of invariant load patterns while

some other methods, such as AMC [5], are using variant load pattern.

In another aspect, advance pushover methods could be categorized into two main groups: displacement-based loading and force-based loading adaptive pushover methods. Antoniou and Pinho [2004] evaluated adaptive and non-adaptive pushover methods based on force load vectors. They concluded that force-based adaptive pushover methods cannot reach to acceptable results while non-adaptive methods using force-based loading vectors could give us more accurate results [7]. Based on these observations, they proposed the displacement-based adaptive (DAP) analysis which uses displacement loading vector instead of force loading vector [6].

Since non-adaptive pushover methods, with the triangular and uniform distributions, do not always provide curves that constitute a lower and an upper bound to the Incremental Dynamic Analysis (IDA) response points, it seems necessary to develop adaptive methods instead of non-adaptive ones [7].

From another point of view, the seismic response of asymmetric buildings in the inelastic range is very complex. Although extensive research has been performed world-wide in the field of inelastic torsional response, general conclusions are lacking. Unfortunately, until recently little attention has been paid to the most realistic but most complex case: multi-storey buildings with bi-axial eccentricity, subjected to bi-directional ground motion. An overview of recent research on torsion was made by Rutenberg [2002].

In this paper, the efficiency of the force-based and the displacement-based adaptive pushover procedures (FAP and DAP), introduced by Antoniou and Pinho [6], [7], is compared in irregular buildings. In order to consider the torsional effects, different structures with different kind of irregularities in plan and elevation are used. The results are compared with conventional procedure and IDA. Both near fault and far fault records are also used.

II. CONVENTIONAL PUSHOVER PROCEDURES

Conventional pushover analysis is the nonlinear incremental-iterative solution of the equilibrium equation

R. Abbasnia is with the Iran University of Science and Technology, Narmak, Tehran, Iran (e-mail: abbasnia@iust.ac.ir).

F. M. Nav, is with the Iran University of Science and Technology, Narmak, Tehran, Iran (corresponding author to provide phone: +989111851943; e-mail: foamdohajeri@civileng.iust.ac.ir).

S. Zahedifar is with the Iran University of Science and Technology, Narmak, Tehran, Iran (e-mail: saeedzahedifar@gmail.com).

A. Tajik is with the Iran University of Science and Technology, Narmak, Tehran, Iran (e-mail: A_tajik@civileng.iust.ac.ir).

$KU=P$ in a finite element formulation, where K is the nonlinear stiffness matrix, U is the displacement vector and P is a predefined load vector applied laterally over the height of the structure in relatively small load increment. This lateral load can be a set of forces or displacements that have a necessarily constant ratio throughout the analysis (fixed pattern). At the end of each iteration, the reaction vector of the structure is calculated from the assemblage of all finite element contributions. The out-of-balance forces are iteratively re-applied until convergence to a specified tolerance is reached [8].

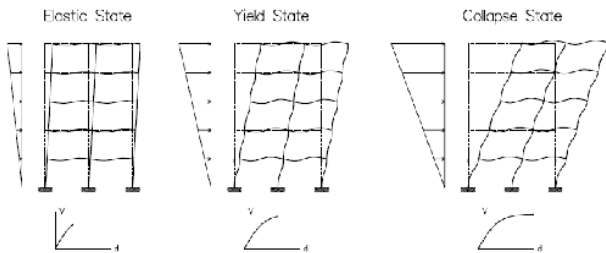

Fig. 1 Yielding sequence through conventional pushover analysis.

The procedure continues either until a predefined limit state is reached or until structural collapse is detected. This target limit state may be the deformation expected for the design earthquake in case of designing a new structure, or the drift corresponding to structural collapse for assessment purposes. Furthermore, it is presumed that the finite element code has been sufficiently verified, so that numerical collapse, as opposed to structural, is not operative. Generally, this procedure allows tracing the sequence of yielding and failure on the member and structure level, as well as the progress of the overall capacity curve of the structure. This process is shown in Fig. 1 [8].

The Displacement Coefficient Method (DCM-[2]) and the Capacity Spectrum Method (CSM-[1]) are the most widely known conventional methods. In the displacement coefficient method, top's maximum expected displacement is considered as structural performance point. The modified displacement of elastic response spectrum is used for estimating the maximum displacement of the equivalent nonlinear single degree of freedom system. The displacement demand of the method is determined from the elastic one by using a number of correction factors based on statistical analyses. According to FEMA 356, the target displacement, which is the maximum displacement occurring at the top of structures during a chosen earthquake, can be determined as

$$\delta_t = C_0 C_1 C_2 C_3 S_a \frac{T_e^2}{4\pi^2} g \quad (1)$$

where C_0 is the differences of displacements between the control node of MDOF (multi degree of freedom) buildings and equivalent SDOF systems, C_j is the modification factor for estimating the maximum inelastic deformation of SDOF

systems from their maximum elastic deformation, C_2 is the response to possible degradation of stiffness and energy dissipation capacity for structural members during earthquakes, C_3 is the modification factor for including the P- Δ effects, T_e is the effective periods of evaluated structures, S_a is the spectral value of acceleration response corresponding to T_e , and g is the acceleration of gravity [2].

The capacity spectrum method (CSM) was first introduced by Freeman [9], [10] as a rapid evaluated procedure for assessing the seismic vulnerability of buildings. Afterwards, ATC-40 [1] investigated CSM procedure in details. This procedure compares the structural capacity in the form of a pushover curve with demands on the structure in the form of an elastic response spectrum. The graphical intersection of the two curves approximates the response of the structure [9]–[11]. In order to account for the effects of nonlinear behavior of structures, equivalent viscous damping has been implemented to modify the elastic response spectrum. Implied in the capacity spectrum method is that the maximum inelastic deformation demand of a non-linear single-degree-of-freedom (SDOF) system can be approximately estimated by an iterative procedure of a series of linear secant representation systems. Therefore, it avoids dynamic analysis of inelastic systems [2].

III. ADVANCED PUSHOVER PROCEDURES

In order to account for higher modes effects, advanced pushover procedures have been developed. As a point of view, these advanced methods can be divided into two main groups: the procedures with invariant load patterns and the procedures with variant load patterns. Paret et al. [12] was the first one who suggested the Multi-Modal Pushover (MMP) procedure. MMP was trying to account for higher modes effects regarding to constant load pattern. MMP was then refined by Moghadam and Tso [13]. Chopra and Geol [4] have developed these methods and proposed a Modal Pushover Analysis (MPA) procedure.

Invariant load pattern cannot consider the changes in the dynamic characteristics of structures. Hence, adaptive pushover procedures have been developed. The first attempt which utilizes fully adaptive patterns was introduced by Bracci et al. [14]. Lefort [15] developed this method. A different adaptive methodology was proposed by Gupta and Kunnath [16], in which the applied load is constantly updated during the analysis. This concept has been developed and used in different versions of advanced pushover methods.

As mentioned before, Antoniou and Pinho [2003], [2004] investigated adaptive and non-adaptive pushover methods and concluded that force-based adaptive procedures cannot predict the seismic responses accurately. Based on these observations, they introduced the displacement-based adaptive pushover (DAP) procedure.

Afterwards, so many other advanced pushover procedures using the displacement-based loading vector are proposed [5] and it seems that the introduction of the displacement-based loading could be a turning point in development of pushover methods.

IV. THE DISPLACEMENT-BASED ADAPTIVE PUSHOVER PROCEDURE

The displacement-based adaptive pushover (DAP) procedure, which is introduced by Antoniou and Pinho [6], is based on using displacements instead of forces in order to make the load patterns. The DAP procedure can be implemented in four main stages; (a) definition of nominal load vector and inertia mass, (b) computation of load factor, (c) calculation of normalised scaling vector and (d) update of loading displacement vector. While the first step is implemented only once, at the start of the analysis, the three remaining parts are repeated at every stage during the analysis [6].

Since in adaptive pushover, in contrast to conventional one, the loading vector shape is automatically defined and updated at each analysis step, the nominal load vector, U_0 , must have a uniform (rectangular) distribution shape in height, in order to prevent from the distortion of the load vector configuration at any analysis step. Knowing the U_0 , the magnitude of the loading vector, U , at each step is calculated by the product of its nominal counterpart, U_0 , and the load factor λ (2). The load factor is automatically increased, by means of a load control or response control incremental strategy, until a predefined analysis target, or numerical failure, is reached.

$$U = \lambda U_0 \quad (2)$$

In order to determine the shape of the load vector (or load increment vector) at each step, the normalised modal scaling vector, \bar{D} is used. This normalised modal scaling factor is computed at the start of every load increment. In order to compute \bar{D} , firstly the scaling displacement vector, D , should be determined. The scaling displacement vectors, which reflect the actual stiffness state of the structure, are obtained directly from the eigen vectors, as described in (3), where i is the storey number, j is the mode number, Γ_j is the modal participation factor for the j th mode, ϕ_{ij} is the mass normalised mode shape value for the i th storey and the j th mode, and N stands for the total number of modes, calculated through an eigenvalue analysis. In the eigenvalue analysis, firstly modal shapes and modal participation factors and finally modal loads are calculated and then, SRSS or CQC combination rules are used to combine them.

$$D_i = \sqrt{\sum_{j=1}^N D_{ij}^2} = \sqrt{\sum_{j=1}^N (\Gamma_j \phi_{ij})^2} \quad (3)$$

The maximum displacement of a particular floor level (the relative maximum displacement between that floor and the ground), cannot be a good indication of the actual level of damage incurred by buildings subjected to earthquake loading.

On the contrary, interstorey drifts, obtained as the difference between floor displacements at two consecutive levels, feature a much clearer and direct relationship to horizontal deformation demand on buildings. Hence, based on interstorey drifts, Equation (3) could be written as:

$$D_i = \sum_{k=1}^i \Delta_k \quad (4)$$

$$\Delta_i = \sqrt{\sum_{j=1}^N \Delta_{ij}^2} = \sqrt{\sum_{j=1}^N [\Gamma_j (\phi_{i,j} - \phi_{i-1,j}) S_{ij}]^2}$$

where Δ_{ij} is the interstorey drifts for each mode and D_i is the displacement pattern at the i th storey which is obtained through the summation of the modal-combined interstorey drifts of the storeys below that level. Equation (4) also includes an additional parameter $S_{d,j}$ that represents the displacement response spectrum ordinate corresponding to the period of vibration of the j th mode, which is called *spectral amplification*. In other words, the modal interstorey drifts are weighted by the S_d value at the instantaneous period of that mode, so as to take into account the effects that the frequency content of a particular input time-history or spectrum have in the response of the structure being analyzed.

Although using the relative displacement between floors in order to determine the floor displacement leads to better results, however, Equation (4) is approximate, because it is assumed that the relative maximum displacement between floors in all storeys occurs at the same time.

Since only the relative values of storey displacements (D_i) are of interests in the determination of the normalised modal scaling factor \bar{D} , which defines the shape, not the magnitude of the load or load increment vector, the displacements obtained by (4) are normalised so that the maximum displacement remains proportional to the load factor:

$$\bar{D}_i = \frac{D_i}{\max D_1} \quad (5)$$

Once the normalised scaling vector \bar{D}_t has been determined, knowing the value of the initial nominal load vector U_0 , the loading displacement vector U_t at a given analysis step t should be updated. Updating the loading vector could be done using one of two alternatives; total or incremental updating.

With total updating, the load vector U_t at a given analysis step t is obtained through a full substitution of the existing balanced loads by a newly derived load vector, computed as the product between the current total load vector λ_t , the current normalised modal scaling vector \bar{U}_t and the nominal load vector U_0 , as shown in (6):

$$U_t = \lambda_t \cdot \bar{D}_t \cdot U_0 \quad (6)$$

With incremental updating, the load vector U_t at a given analysis step t is obtained by adding the load vector of previous step P_{t-1} a newly derived load vector increment, computed as the product between the current load factor increment $\Delta\lambda_t$, the current normalised modal scaling vector \bar{U}_t and the nominal load vector U_0 , as shown in (7) :

$$U_t = U_{t-1} + \Delta\lambda_t \cdot \bar{D}_t \cdot U_0 \quad (7)$$

The procedure of the force-based adaptive pushover (FAP) is the same but the only difference is the application of force-based loading vector instead of displacement. In this paper, both procedures will be investigated.

V. STRUCTURAL MODELS AND GROUND MOTIONS

A. Models

In order to compare the accuracy of DAP and FAP methods in seismic response estimation of irregular buildings, regarding to torsional effects, different types of irregular structures has been chosen. Using these models, an extensive study has been carried out, involving static and dynamic nonlinear analysis. In this section, the models will be introduced.

The ICONS Frame: This structure is tested in Ispra, Italy in May 1999 (Fig. 2). It is selected for its strong irregularity in plan and its varying in-plane stiffness. The structure was designed by Carvalho et al. [1999] with the objective of representing design and construction practice in many Southern European and Mediterranean countries in the 1950's and 60's. The design procedure followed regulation requirements that were in use then, and made use of materials



Fig. 2 The ICONS frame

typically employed at the time. A detailed description of the structure may be found in Carvalho et al. [1999]. The structure has been extensively studied analytically.

The four-storey frame consists of two bays of 5.0m span and one bay of 2.5m span. The inter-storey height is 2.7m, the slab thickness is 0.15m with a width of 4.0m. This structure has been modeled as a two dimensional frame. During the analyses, this model is known as M1.

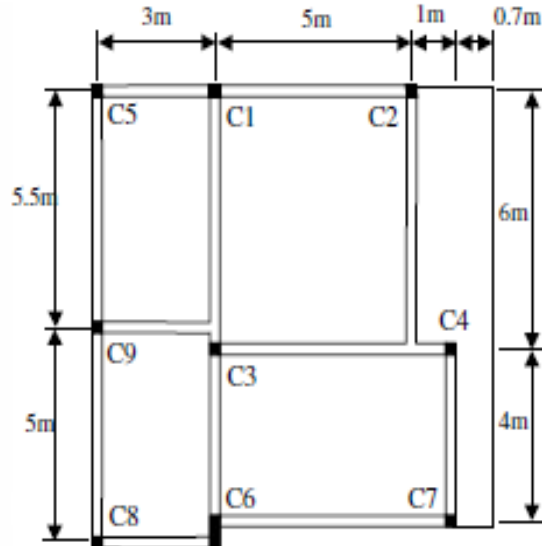

Fig. 3 The SPEAR frame, Plane.

The SPEAR frame: A three dimensional based on a full scale structure tested in 2002 within European network “Seismic Performance Assessment and Rehabilitation (SPEAR)”. It features irregularities both in plan and elevation (Fig. 3 and Fig. 4) [17].

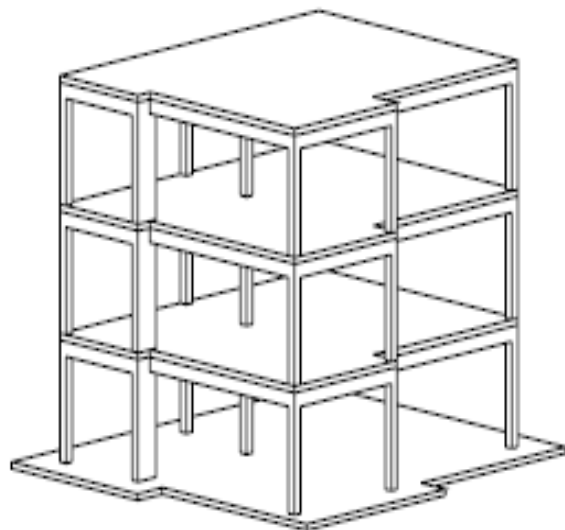

Fig. 4 The SPEAR frame, Actual Structure.

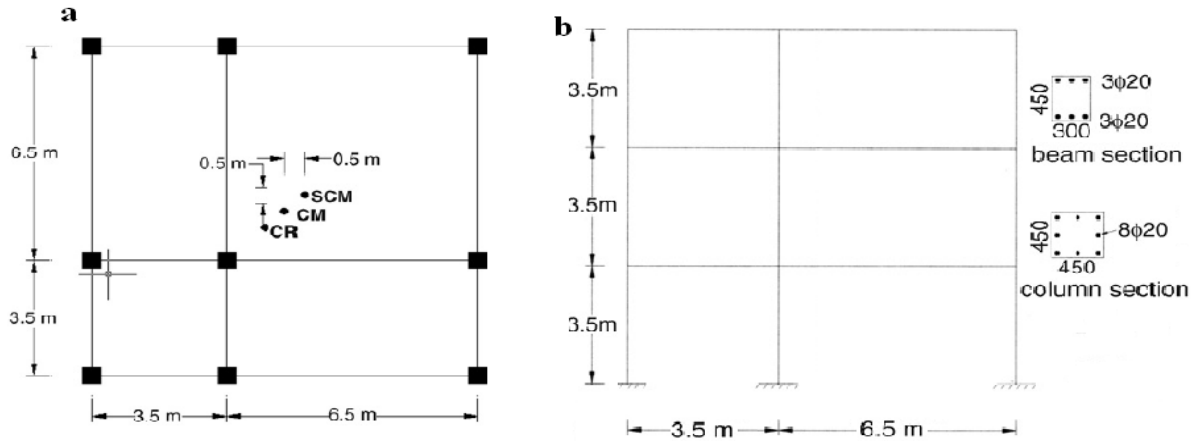

Fig. 5 The three storey bi-directionally eccentric system – M3 (a) Plan view (b) Elevation view and sections properties

The test building has been designed for gravity loads alone, using the concrete design code applied in Greece between 1954 and 1995. It was built with the construction practice and materials used in Greece in the early 70's. The structural configuration is also typical of non earthquake-resistant construction of that period [17]. During the analyses, this model is known as M2.

The third model is a 3 storey concrete frame building which has an asymmetrical structural plan. The system has a bi-directional eccentricity of 5% of the plan dimension in both directions. The description of this model is shown in Fig. 5 (a) and (b). All dimensions are in millimeter unless stated otherwise.

This model, which is adopted from Erduran [18], is a three dimensional model. During the analyses, this model is known as M3.

Next model is a 12 storey 2 dimensional steel frame building which is vertically irregular. The three dimensional form of this model is introduced in FEMA 451 [19], but here only the two dimensional model is investigated. Columns range in size from W24x146 at roof to W24x229 at ground level. Beams vary from W30x108 at roof to W30x132 at ground level. Fig. 6 shows the schematic description of the model. More details about the model could be found in [19]. This model is known as M4 during the analyses.

The last model, which is originally adopted and developed from Ray Chaudhuri and Villaverde [20], is a four storey steel frame building, which in plan and elevation is irregular. The building has a uniform mass distribution over the height and a non-uniform stiffness distribution. Fig. 7 (a) shows the plan of the framing system and Fig. 7 (b) shows the elevation of the frame. This model is referred as M5 during the analyses.

As mentioned above, different models with different kinds of irregularities and also different materials are chosen to perform a comparative study on efficiency of force-based and displacement-based adaptive procedures in seismic response estimation of buildings with considerable torsional effects.

Table I shows the brief descriptions of models M1 to M5.

TABLE I
REVIEW OF MODELS

Models	Number of Storeys	Irregularity		Modeling	Material
		Plan	Ele.		
M1	3	×	×	2D	concrete
M2	3	×	×	3D	concrete
M3	3	×	×	3D	concrete
M4	12		×	2D	steel
M5	4	×	×	3D	steel

The analyses have been implemented using the open source finite element platform, OpenSees [22].

B. Ground Motion Ensemble

In order to develop a set of benchmark responses against which to compare the results of analyses, a set of records having far-fault and near-fault characteristics were compiled.

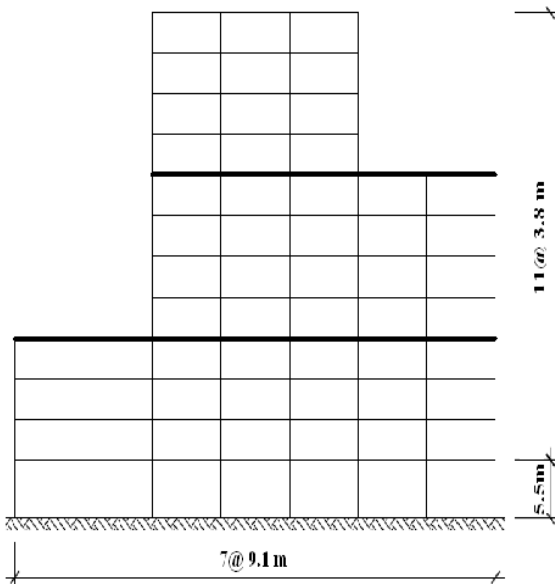

Fig. 6 The 12 storey steel frame

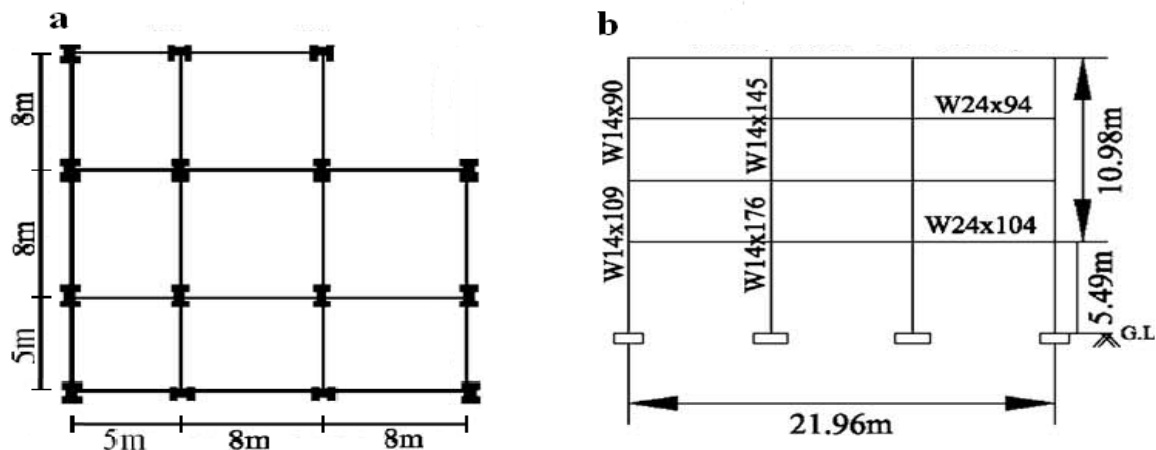

Fig. 7 The four storey steel frame – M5 (a) Plan View (b) Elevation

The characteristics of the records are summarized in Table II [21].

VI. RESULTS

For each one of the considered structures, the results are presented. Capacity curves for different models are depicted. In Fig. 8 and Fig 9, a series of top displacement versus base shear plots, comparatively illustrating static and dynamic results obtained for different models subjected to equally diverse earthquake records, is given. For each model, two pushover curves are presented, one resulted from using far-fault records and the other one is resulted from using near-fault records. In order to compare the results, for each model, pushover curves resulted from Adaptive pushover procedures (force-based and displacement-based), IDA and conventional pushover methods are depicted in the same graph.

It is observed that for structures with irregularity in plan and elevation, IDA points were different from pushover analyses results, adaptive or non-adaptive. In other words, it seems that adaptive pushover procedures, both force-based and displacement-based methods, cannot predict the seismic

responses of irregular structures precisely. Just for M4 which was only vertically irregular, the results seem to be better.

In structures with asymmetric plans, by increasing the irregularity, the accuracy of results is decreasing, as shown in Fig. 8 and Fig. 9.

For most of these analyses, results of the force-based and the displacement-based adaptive procedures were very close. Also there was not a significance difference between near fault and far fault results. Only in M1 (The ICONS Frame) which in plan and elevation was irregular, the results for far fault and near fault records were different.

Based on the results, it seems that for irregular structures, especially for three dimensional irregular buildings which torsional effects play an important role in the structure, the conventional pushover analysis gives better results rather than the displacement-based or force-based adaptive pushover procedures.

In addition to above, in structures with plan irregularity, such as M2 and M5, for both force-based and displacement-based, the difference between IDA and adaptive and conventional pushover analyses were more than others.

TABLE II
CHARACTERISTICS OF THE GROUND MOTIONS

Record	Year	Ground Motion		Magnitude	Distance ^a (km)	PGA (g)	PGV (cm/s)	PGD (cm)
		Far-fault	Near-fault					
Kobe	1995	×		6.9	26.4	0.345	27.6	9.6
Kobe	1995		×	6.9	0.3	0.611	127.1	35.77
Northridge	1994	×		6.7	19.3	0.290	19.7	7.45
Northridge	1994		×	6.7	7.1	0.455	92.8	56.64
Imperial Valley	1979	×		6.5	26.0	0.195	8.8	2.78
Imperial Valley	1979		×	6.5	7.6	0.235	68.8	39.53
Tabas	1978	×		7.4	17.0	0.406	26.5	8.75
Tabas	1978		×	7.4	3.0	0.852	121.4	94.58
San Fernando	1971	×		6.6	25.8	0.145	17.3	2.88
San Fernando	1971		×	6.6	2.8	1.226	112.5	35.5

^a Closest distance to fault

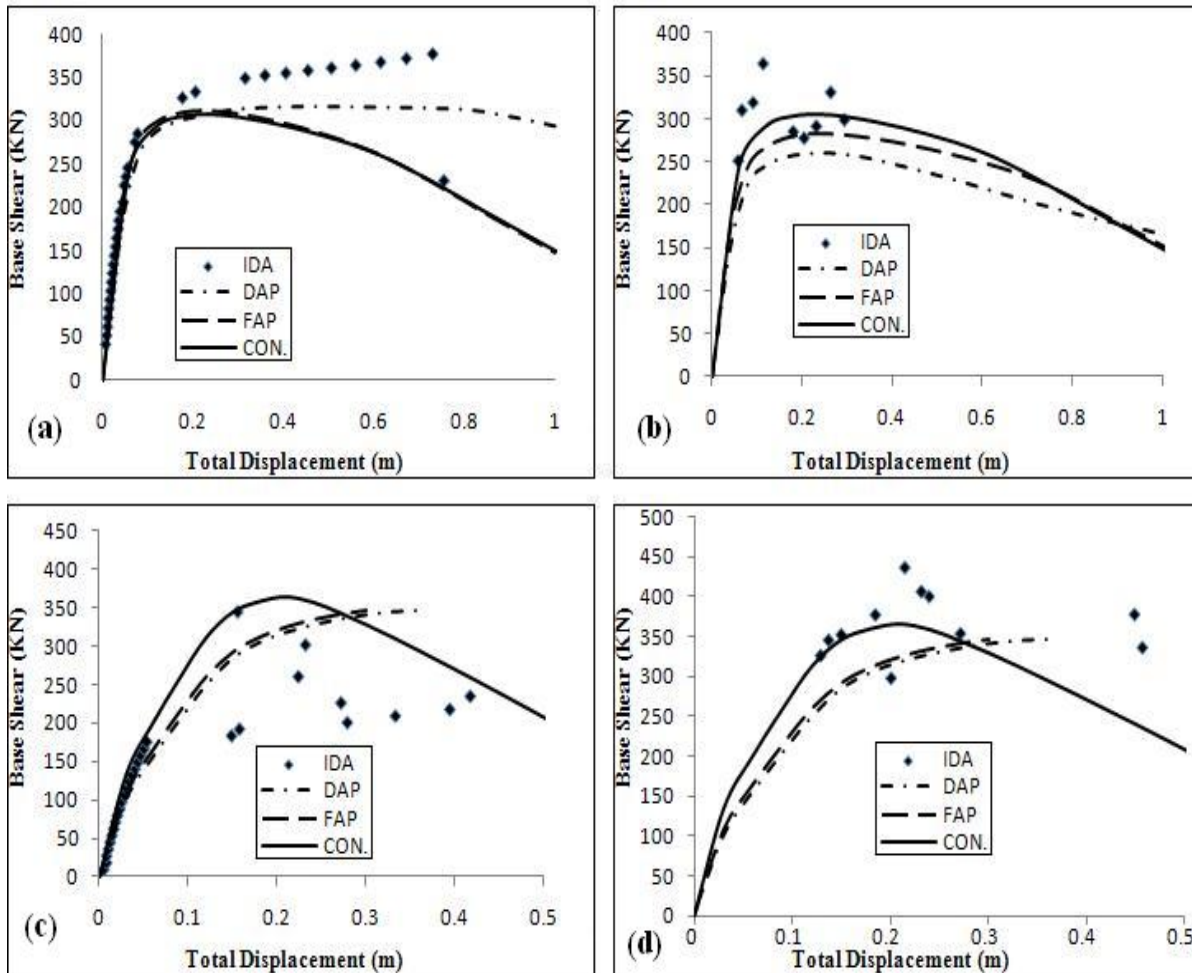

Fig. 8 Pushover Curves (a) M1, Far-fault record (b) M1, Near-fault record (c) M2, Far-fault record (d) M2, Near-fault record

VII. CONCLUSION

The accuracy of the displacement-based and the force-based adaptive pushover procedures (DAP and FAP) which were introduced by Antoniou and Pinho [2004], in seismic response estimation of irregular buildings, are investigated. Irregular structures in plan an elevation with considerable torsional effects have been analyzed.

Four different structures with plan irregularity and also a structure with elevation irregularity have been analyzed. Both far-fault and near-fault records have been used. To verify these analyses, the Incremental Dynamic Analysis (IDA) is used.

A summary of the main observations and general conclusions of the present study is presented below:

- Adaptive pushover methods, both the displacement based and force-based methods, cannot predict the seismic responses of irregular structures, especially the structures with plan irregularity.
- It seems that conventional pushover analysis can predict the seismic responses of irregular building

more accurate than adaptive methods.

- By increasing the irregularity of the structures, especially the irregularity of plan, the accuracy of results is decreasing.
- The difference between the displacement-based and the force-based adaptive procedures in three dimensional structures with considerable torsional effects is very low.
- In irregular structures, the conventional pushover analysis and adaptive procedures provide close results.

The above study indicates that further research work is required to compare the adaptive and non-adaptive and also the displacement-based and the force-based adaptive pushover procedures in seismic response estimation of irregular buildings. Different other irregular structures should be considered, especially buildings with considerable plan irregularity which torsional effects are noticeable. It seems that adaptive procedures need more improvements to for enhancing in irregular structures.

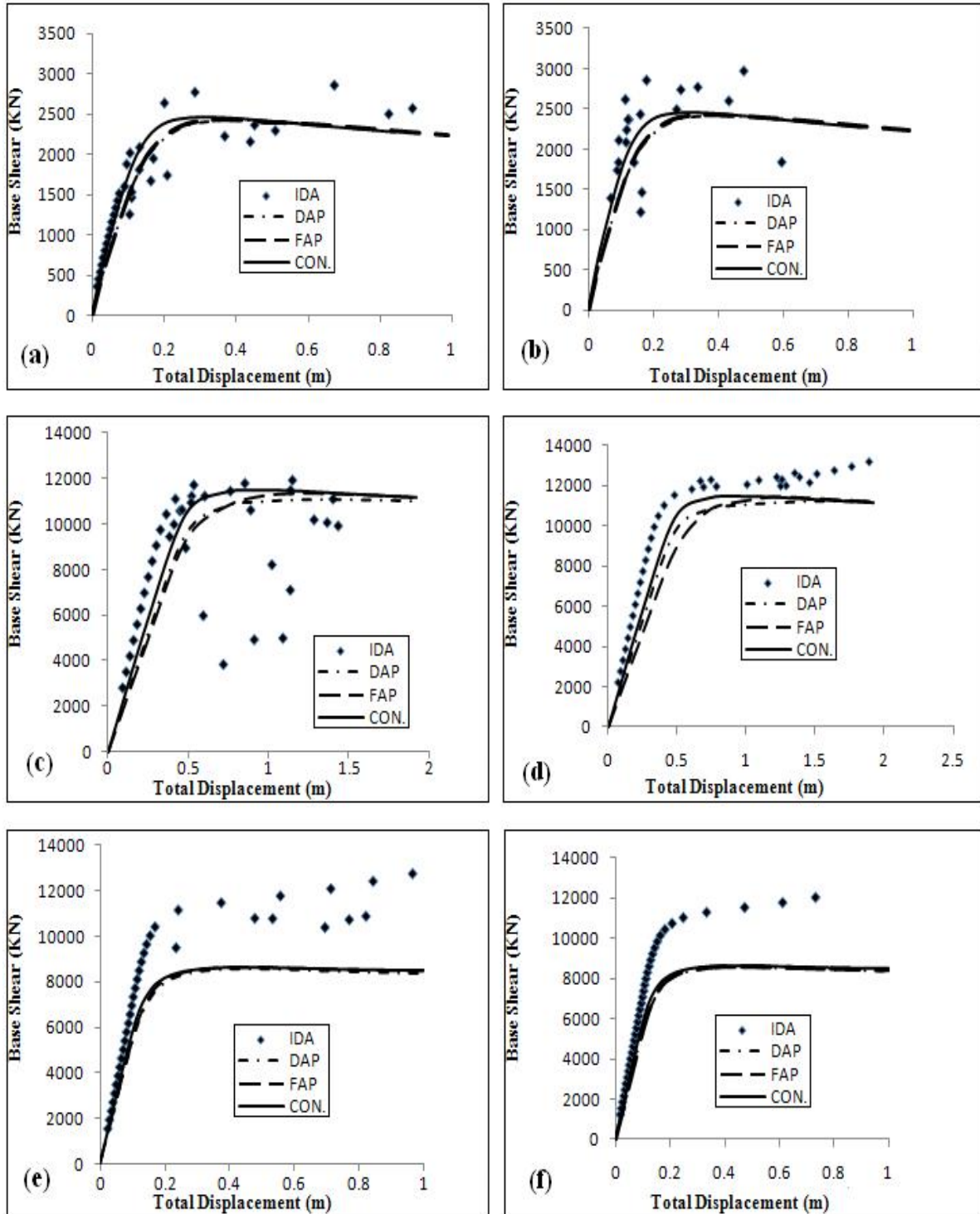

Fig. 9 Pushover Curves (a) M3, Far-fault record (b) M3, Near-fault record (c) M4, Far-fault record (d) M4, Near-fault record (e) M5, Far-fault record (f) M5, Near-fault record

ACKNOWLEDGMENT

The authors would like to acknowledge the financial support provided by the civil engineering department of Iran University of Science and Technology (IUST).

REFERENCES

[1] ATC-40, 1996, "Seismic evaluation and retrofit of concrete buildings," Applied Technology Council, Volume 1, Redwood City, Calif.

- [2] FEMA 356, 2000, "Prestandard and Commentary for the Seismic Rehabilitation of Buildings," Federal Emergency Management Agency, Washington, D.C.
- [3] Kunnath, S. K., and Kalkan, E. _2004_. "Evaluation of seismic demands using nonlinear procedures in multistory steel and concrete moment frames." *ASET J. Earthquake Technol.*, 41_1_, 159–182.
- [4] Chopra, A. K. and Goel, R. K., 2002, "A modal pushover analysis procedure for estimating seismic demands for buildings," *Earthquake Engineering and Structural Dynamics* 31, 561-582.
- [5] Kalkan, E., and Kunnath S. K., 2006, "Adaptive Modal Combination Procedure for Nonlinear Static Analysis of Building Structures," *J. Earthquake Eng.*, 132(11), 1721-1731.
- [6] Antonio, S., and Pinho, R., 2004, "Development and verification of a displacement-based adaptive pushover procedure," *J. Earthquake Eng.*, 8(5), 643–661.
- [7] Antonio, S., and Pinho, R., 2004, "Advantages and Limitations of Adaptive and Non-adaptive Force-Based Pushover Procedures" *J. Earthquake Eng.*, 8(4), 497–522.
- [8] Papanikolaou, V. K., and Elnashai, A. S., and Pareja, J. F., "Limits of Applicability of Conventional and Adaptive Pushover Analysis for Seismic Response Assessment," Mid-America Earthquake Center, Civil and Environmental Engineering Department University of Illinois at Urbana-Champaign.
- [9] Freeman, S. A., and Nicoletti, J. P., and Tyrell J.V., 1975, "Evaluations of existing buildings for seismic risk - A case study of Puget Sound Naval Shipyard, Bremerton, Washington," *Proceedings of the 1st U.S. National Conference on Earthquake Engineering*, p.p.113–122.
- [10] Freeman S. A., 1978, "Prediction of response of concrete buildings to severe earthquake motion," *American Concrete Institute*, Detroit, Publ. SP-55, 589–605.
- [11] Freeman S. A., 1998, "Development and use of capacity spectrum method," *The 6th US National Conference on Earthquake Engineering=EERI*, Seattle, Washington, Paper No. 269.
- [12] Paret, T. F., Sasaki, K. K., Eilbeck, D. H. and Freeman, S. A., 1996, "Approximate inelastic procedures to identify failure mechanisms from higher mode effects," *Proc. of the Eleventh World Conference on Earthquake Engineering*, Disc 2, Paper No. 966
- [13] Moghadam, A. S. and Tso, W. K., 2002, "A pushover procedure for tall buildings," *Proc. of the Twelfth European Conference on Earthquake Engineering*, London, United Kingdom, Paper No. 395.
- [14] Bracci, J. M., Kunnath, S. K. and Reinhorn, A. M., 1997, "Seismic performance and retrofit evaluation of reinforced concrete structures," *Journal of Structural Engineering* 123(1), 3-10.
- [15] Lefort, T., 2000, "Advanced pushover analysis of RC multi-storey buildings," *MSc Dissertation*, Department of Civil and Environmental Engineering, Imperial College London, United Kingdom.
- [16] Gupta, B. and Kunnath, S. K., 2000, "Adaptive spectra-based pushover procedure for seismic evaluation of structures," *Earthquake Spectra* 16(2), 367-391.
- [17] Fardis, M.N., 2002, *Design of an Irregular Building for the SPEAR Project - Description of the 3- Storey Structure*, University of Patras
- [18] Erduran, E., "Assessment of current nonlinear static procedures on the estimation of torsional effects in low-rise frame buildings," *Engineering Structures* 30 (2008) 2548–2558
- [19] FEMA 451, 2006, "NEHRP Recommended Provisions: Design Examples," Federal Emergency Management Agency, Washington, D.C.
- [20] Ray Chaudhuri S, Villaverde R. Effect of building nonlinearity on seismic response of nonstructural components: a parametric study. *ASCE Journal of Structural Engineering* 2008;134(4):661–70.
- [21] Pacific Earthquake Engineering Research Center, <http://peer.berkeley.edu/smcat>
- [22] OpenSees, (2008), "Open system for earthquake engineering simulation." (<http://opensees.berkeley.edu>)