

Research on IBR-Driven Distributed Collaborative Visualization System

Yin Runmin, and Song Changfeng

Abstract—Image-based Rendering (IBR) techniques recently reached in broad fields which leads to a critical challenge to build up IBR-Driven visualization platform where meets requirement of high performance, large bounds of distributed visualization resource aggregation and concentration, multiple operators deploying and CSCW design employing. This paper presents an unique IBR-based visualization dataflow model refer to specific characters of IBR techniques and then discusses prominent feature of IBR-Driven distributed collaborative visualization (DCV) system before finally proposing an novel prototype. The prototype provides a well-defined three level modules especially work as Central Visualization Server, Local Proxy Server and Visualization Aid Environment, by which data and control for collaboration move through them followed the previous dataflow model. With aid of this triple hierarchy architecture of that, IBR oriented application construction turns to be easy. The employed augmented collaboration strategy not only achieve convenient multiple users synchronous control and stable processing management, but also is extendable and scalable.

Keywords—Image-Based Rendering, Distributed Collaborative Visualization, Computer Supported Cooperative Work, Model and Simulation, Modular Visualization Environment.

I. INTRODUCTION

THE traditional approach for generating virtual views of a scene is to render directly an appropriately constructed 3-D model in geometry. More recently, image-based rendering (IBR) techniques using multiple images in different angle of view to generate a synthetic view develop rapidly as a promising research area. From Plenoptic function [1] to first commercial product 'QuickTimeVR' [2], IBR advance from theory to practical application. There appears many advance IBR techniques [3] [4] [5] to expend IBR apply region, to raise its running speed, and to improve its fidelity. In general, they often rely on image warping, image interpolation and image synthesis techniques.

IBR applications focus on two categories in technical usage: partial geometrical polygon replacement with dynamic texture image and direct display artificial image as scene model. Texture image replacement technique is widely applied for

Manuscript received June 21, 2006. This work was supported in part by the China Ten-Five years Pre-research under Grant 413090303.

Yin Runmin is with the School of Automation Science and Electric Engineering, Beijing University of Aeronautic and Astronautic, Beking, 100083 China (phone:+86 010 88527446; fax: +86 010 88527444; e-mail:yinrunmin@163.com).

Song Changfeng is with the School of Automation Science and Electric Engineering, Beijing University of Aeronautic and Astronautic, Beking, 100083 China (e-mail:bjscf@21cn.com).

decimation of triangle meshes and raising the speed of rendering task, while backbone in these visualization systems is graphics-based rendering. The latter as our interest and emphasis contrarily works on the ground of pure IBR supported application. It should be notice that current IBR oriented applications usually neither build in any distributed framework nor support anyhow complete collaborative job.

Distributed Collaborative Visualization (DCV) system aims at supporting multi-user uncertainly location and operation, vase data resource geographically distributing, and is referred as a prominent application with aid of Computer Support Cooperative Work (CSCW) [6] technology. This kind of system allows participants virtually work together in a virtual environment playing different role with special right and responsibility accordingly. They can handle diverse resource and identically operate on the appointed result.

In 1980s, many systems experience the pressing demand for supporting distributed processing. The loop of visualization task begins to lean to be placed in different processor as hard task fulfilled in server and easy work performed in client station, which optimizes the mathematical resource configuration. Yet these systems are designed for solo worker, thus distributed property of them is limited without user operation dispersing. Under this mode of system proceeding, collaboration can and just can show out when all participants cluster around a single workstation. In case of theoretical visualization environment, the definition of distributed property include: a)similar MVE(modular visualization environment) structure decomposing functional stage of visualization flow, such as input, analysis, filter, modeling, rendering, and respectively placing them in suitable client/server machine; b)bound of partly restored data and uncertain user dispersing.

Current powerful visualization systems such as IRIS Explorer, Application Visualization System (AVS), Khoros and IBM Data Explorer provide a range of services that only hold a single user interface. Users need to share their thought or image result by traditional network transmission tools. To enable a collaborative environment, designers of these systems expend their work to reach at this goal by introducing MVEs[11]. These MVEs allow users synchronously access to unique research object and visualize it by their convenient rendering tool, while their co-operations are constrained to obtain simple mirror of data or result, which is called shallow collaboration style (SCS) or outcome-shared style. The researches in CSCW act as a good director for collaboration

style extension, which enable multiple data and control channel connection. Style of that is refer as deep collaboration style(DCS).

Systems under SCS are looked on as an extension of single-user application. Only copy of the outcome from controller can be broadcast through network to others at one time. It is simple to implement SCS in visualization system, but the nodes with excellent capability may unskillfully hold in single visualization process, and simultaneously lead to a heavier burden on network when more users join in. With DCS grant, users can generate and keep their own control parameter through visualization process, other than directly achieve result image under share control. Nevertheless, control for sharing in current DCS applications need to be predefined and changeless, even under consideration of different object. So systems often solidify operable object for collaborating on that including outcome image and process control parameters corresponding to inflexible system model. FAST CFD[10] extended system with employing script-controlled visualization processing to make shared object changeable. Being an assistant control part across the whole system, the processing exactly works whenever each user keeps a full copy of database to ensure coherence at result.

The key problem of a collaborative visualization system is how to implement the visualization process when share object exist concurrently. Namely all systems need to notify each participant who can generate the share parameters and the time share object should be submitted, to assure that at any time other participants should know the process status and detail of the share object. The simple solution is to import token mechanism: participants are divided into two functional region administrator and partners or master and slaves. Only the administrator can appoint and handle the share object throughout the visualization process. As another approach, the event-driven collaboration policy relies on predefined event to trigger share module and decide the content of sharing. Participants unnecessary know what they send to others other than perform under guide of visualization pipeline.

Greg Johnson[7] categorized applications exist today that provide visualization capabilities in a collaborative context by the level of shared control they provide over the visualization process as local control, local control with share data, limited shared control and fully shared control. All type of realization face three challenges: refreshing share object data to guarantee the consistence so that each participant see the same and handle the same; avoiding control interurrence and make sure the control triggered implement consistently; optimizing latency and bandwidth usage by somehow flux management to reduce sum of data transmission, such as data compression, pre-fetching, database dynamic copy, interest domain management, pre-decided data mechanism etc.

COVISA [9] provides a model of collaborative visualization dataflow and allows users keep their private data and particular visualization tool. It supports synchronous and asynchronous work with regret that COVISA developed primarily for two user collaboration and its centralized service management mode is not suit for frequency login and logout

or collaboration operation shifting freely. The central server error may bring a deadly system corruption. Additionally COVISA does not take exception prevention and mistake recuperation into account with only single visualization processing supported.

Consequently, though visualization systems today support distributed resource combination, users control serialization, and modular visualization pipeline, they conceptually did not reach the demand for DCS.

It may be notice that current distributed visualization systems are on the basis of traditional graph-based rendering technique, which is base on graph-base rendering visualization dataflow and pipeline. In sense of IBR technology, next chapter describe an IBR-Driven visualization dataflow model and its extension for collaboration. The third chapter discusses a novel framework which embodies the virtue of introducing the model at detail and provides a prototype of realization. After that we outline some experimental result and the conclusion will be made at last with future work list.

II. IBR-DRIVEN VISUALIZATION DATAFLOW MODEL

Haber and McNabb [12] model for visualization in a dataflow environment describe visualization processes in categories: filter, map and render stages. Filtering involves taking some data from an input process and refining it. Mapping the filtered data converts it to a geometrical representation and finally the rendering stage generates a visible image from this geometrical information. Since IBR techniques are used for generating synthetic outcome by image series, the rendering metaphor turn to be image instead of geometrical meshes or other graphical information, IBR-Driven real-time application dataflow module(see Fig. 1) as sample, filter, setup, re-filter, rendering and post-position while IBR get a simple pipeline: sample, filter, setup, and rendering. After sampling a scene into series images with particular camera parameter and pre-defined position and orientation information, original controllable images are registered for rapid filtering. Users generally extract images at filter stage according to register information and setup them into another format, such panoramic, depth image. Rendering involves one or several image in special format using particular algorithms researched recently, such as interpretation, morphing, mosaic, blending etc. Application input call for a novel outcome which need to re-filter the medium format for real-time rendering. Finally post-position optimize next rendering round under current position information with prediction. In case of IBR techniques, it is notice that filtering involves extracting appropriate image under unique resolution and around interest domain and the result after setup become part of raw image for next sub pipeline with filter and setup, which lead to an overlapping pipeline as following:

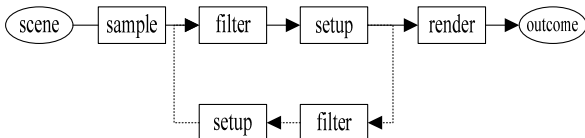

Fig. 1 IBR-Driven visualization pipeline

To extend Haber and Mcnabb model for collaboration, each stage needs an extra function body for data and control parameter sharing and acceptance. In collaborative IBR-Driven dataflow model (see Fig. 2), each participant holds its visualization pipeline which can exchange information and enable interaction with others as common function body moreover. Synchronization module existed in each pipeline would guarantee data consistency and control matching after the collaboration process. Optionally users are allowed for implementing each visualization module using local setting or simply download duplication from the other instead.

In collaboration environment, under an emphasis of flexibility, a visualization dataflow allow users process different visualization thread categorized as main thread and additional thread. The control master would manage main visualization thread of all participants while the additional thread executes locally and only be visible for native user as a tool for additional analysis. Similar to Haber and Mcnabb model extension, each stage in IBR-Driven visualization pipeline contains an exchange information pool supporting data and control parameter. Furthermore, medium image can be view if partners want to as extra data sharing between the same stages.

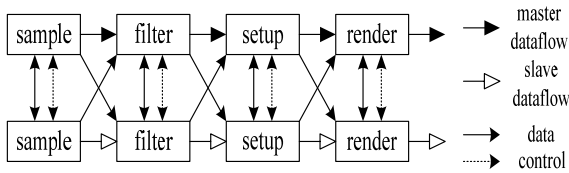

Fig. 2 Pipeline in collaboration mode

III. IBR-DRIVEN DCV SYSTEM FRAMEWORK

DCV systems apply to IBR-Driven applications need to maximum the convenience interaction between multi-users and support for resources/users in diverse location, without taking rendering stage techniques and consecution of result in single user station as the critical factor. Following provides an IBR-Driven DCV framework at detail; finally bring forward a prototype for IBR oriented applications.

1) System architecture and components

To achieve high flexibility of visualization process, a similar COVISE architecture is describe as triple hierarchy(see Fig. 3): central visualization server(CVS), local proxy server(LPS) and visualization aid environment(VAE), where LPS and VAE are placed together locally in client workstation. CVS unlike the central server in COVISE that there is loose relation between server and client station, and it only make

response to operations triggered by action from client workstation such as process register, user login and logout, process status record, visualization tool and resource register etc. CVS is careless for real-time collaboration interaction which would be realized by LPSs.

Referred to IBR-Driven dataflow model, the communication between any components within these three hierarchies can be remark as two usual categories: data and service code, control parameter and direct management manuscript so that restricts CVS to work with the first flow. The light weight architecture prevents system halt whenever occur any mistake in CVS.

There's status for task proceeding following the previous dataflow model controlled by the CVS, and the LPS can get a mirror for each task registered in CVS within own group. LPS will monitor the dataflow transaction and inform user by VAE.

Different users in heterogeneous network use uniform protocol defined in LPS to register in CVS. As the main controller over collaboration, LPSs need to localize user unique index, accept and reply request for collaborative operations from VAE or other LPS, interpret the request and interviewer index, finally interact with the LPS of interviewer or submit task to VAE. The maintenance of LPSs will be the most important issue taking the collaboration destination into account. Both the "sample" and the "filter" stages are implemented under guidance of LPSs by somehow data or service code.

VAE is the only interface to accept user input and provide outcome image and real-time information, which was regarded the last stage throughout the pipeline as "render", after implement visualization process locally. Except to generate just the consequence, VAE take more responsibility to explicitly interpret the medium after any setup, the only special stage for allow any useful coarse-to-refine IBR requirement. Emphasis the framework makes is to guarantee the localization of rendering in VAE not only isolates modules of the data acquisition and rendering to speed up visualization, but also decreases real-time network traffic.

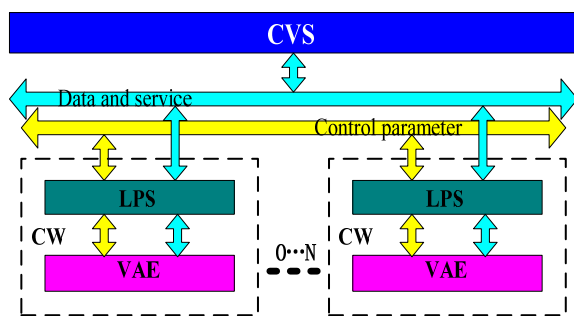

Fig. 3 Triple hierarchy distributed collaborative visualization framework

2) Parallel work

By focusing now at the process level, the system uses a group process policy to enable parallel work in the view of collaborative mode. Sponsor participant first registers a process in CVS through local LPS, and then CVS create a

group-work space and assign an index which is transparent to any on-liner. After any partner proposes to join in this group under allowance, CVS will inform existed LPSs in this group to build up connections to the freshman by scripting the information in CVS and configuring in each LPSs. At the same moment, any joiner still can sponsor a new group to perform other process. Group-oriented processes not only enable parallel work but also enable collaboration over multiple experts in a more clear and clean environment.

At the interest of maintenance of visualization dataflow in a group-to-group collaborative environment, rather than simple interaction with single group, a collaboration ware is provided to build up a connection between groups with share of data but control. This collaboration ware dispersed throughout any registered group in LPSs, where deal with the data exchange and other kind of communication such as process descriptions and definitions.

3) Extended token passing mechanism

The most eminent method to guarantee the consistency of data flow and process implementation is to divide participants into single master and slaves, which allow only one token passed within group process. Even in the current 'full share' mode, systems in visualization generally leave the token unchangeable cross all processes. This so-called SCS is unable to satisfy flexible collaboration. In this advanced visualization system, LPSs control the real-time token passing without any CVS work as taking account of non-central management. Token keeper can see all the shared data or control parameter any time, select a duplicate from some one include himself and then broadcast it throughout group.

Though the participant without token cannot decide current stage outcome, his personal data or control parameter still have chance to be used throughout its group. Furthermore, the slave can follow the unique pipeline, or close the door without any sharing and keep own data and control private, while it can not deny the share form from master within the main process. There is a virtual global token controller consist of token passing modules exist in each LPS with responsibility for distributing all share object so that synchronizes each visualization stage for the sake of capability exertion in station machines.

Token holder can not only decide the share form of stage outcome but also select the next token owner in a group. Furthermore, token's another function appears in the initial login register that group member in the other word is selected by the group sponsor or token owner if any token shifting happened before proposal to join. This member restriction actually prevents risk of private information leakage by avoiding stranger enter group work and improve the secrecy.

4) Free configured visualization operation

In collaborative visualization systems by far, participants only work under 'local control' mode without known about any visualization specification, which is against the collaboration attempt. Thus it is necessary to made all operations during visualization process transparent to any

partners. An interpreted script passing system applies to all kind of information is presented, where helps to register such as users information, visualization module, visualization tool and its descriptions, control parameters and its restriction, outcome style and count etc.

By using interpreted script, participants can share their visualization operations with data and control parameters and implemented tools from others. Firstly they need to register the operation as service contain information as name, size, site, input, output, description etc. in local LPS by which transmit to CVS where organize a tool list. On-liner can download registered service before gain the authorization of it. The authorization is generated by local LPS according to the privilege of user defined in CVS and appointed open level of service. It is notice that the output of services restrict to image or data structure contain coordinates and color value or density when we focus on IBR-Driven application.

It is obviously that the local visualization tool execution accelerates the visualization process. The modular collaborative visualization with aid of script motivates the flexibility of system.

5) Application framework

To achieve all key components presented above, an application framework is put forward where provides different type of resource and service functions described in special script format, such as register, query, and download etc. The collaboration core is embodied by LPS which take control of token passing, process direction, and interaction within group or between groups, under consideration of data secrecy and safety. CVS is light weight server with responsibility of only record registered information of resource, service and group member. DVE provide a visualization environment droved by different service with a service register virtual machine and download tool. As a result, script interpreter is place in CVS, LPS and VAE.

The prototype of IBR-Driven DCV system(see Fig 5) provides a integrated service that satisfy the requirement of maximum convenience and high quality with least user input and configuration. The application can be built on only two predefined script that one is about register user, service, and the other is about a group process activity. The collaboration with share of data and control parameter would be achieved by previous components in triple hierarchy.

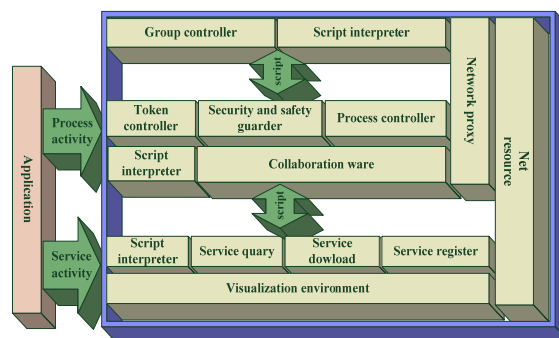

Fig. 4 prototype for IBR oriented applications

IV. EXPERIMENTAL RESULT

We made an experiment (see Fig. 5) that there is a CVS software component in a single machine and several local groupware copied dispersed in stations. The participants firstly need to connect to the CVS by registration and login that means to a new copy of manuscript describing user information was build up and distributed. Once CVS did not work properly, there will popup message needed to be conformed by user that local PVS will serve as an integrated CVS and recommend to keep scripts until any CVS appearance. System will shift all registration record to a new CVS automatically.



Fig. 5 Experimental VAE snap

After work group creation, participants can raise any task with any services supported. The services can be native or distant. Other participants can now join in and get the control token and share any tools as services provided, which under monitor by IBR-dataflow selected by token owner.

During the visualization collaboration, participant can create a new task as group container or join an existed one. Anytime the service including tools and data resource may be flexible to handle by CVS refreshing.

After the experimentally collaborative work, user can easily review the process and keep it as permanent record. Furthermore this visualization system also helps to build IBR-driven application such as walk-through and digital simulation etc.

IV. CONCLUSION AND FUTURE WORK

The original attempt of visualization is to provide a direct tool for analysis and observation on simulation result which is revealed as a team work. However current distributed visualization systems supporting collaboration exist following shortcomings:

- a) Changeless dataflow does not fit for diverse applications.
- b) Do not meet the requirement for full sharing with data, control parameter and service.
- c) Share management in multi-level collaboration is limited in server-client mode.
- c) Master in collaboration activity only serves as an outcome generator without any process co-operation.
- d) Visualization process generally appears in solo system,

and do not supports parallel work and collaboration in group.

e) Do not base on IBR and can not extend to IBR-Driven applications directly.

This paper considers the characters of recently hot area IBR in dataflow description. Then it presents a general model of visualization system using pure IBR technique, which was used for IBR-Driven applications construction. For the sake of collaborative visualization with IBR, a triple hierarchy model is put forward, where CVS, LPS and VAE function correlatively to enable a convenient DCV platform that is easy to employ to fulfill collaborative visualization tasks. Each stage of IBR oriented visualization process, including sample, filter, setup and render, supports interaction each other within the group member, who can obtain data and control parameters and medium outcome. Since the system architecture is light weight and enables non-central control and locally processing, applications based on it do guarantee the network low latency and system extendibility and scalability. The concept of group collaboration and extended token passing leads to a clear division of users as master and slave with different responsibility in a group. This architecture provides a scope for exchange data and control parameters and visualization service except allowing private resource, which meet the requirement of DCS, by which the prototype achieved distributed IBR-Driven collaboration visualization application construction easily.

In the distributed visualization system, image transmission will harden the overload on network. Li[8] points out that image compressing work can speed up the transmission several times. Thus, to modify the visualization quality, we are going to adopt a compressing algorithm directly or develop a new one. Furthermore, the system do not take common communication between participant into account, and even lack of result analysis tool for collaboration, which is another future challenge.

REFERENCES

- [1] E. Adelson and J. Bergen, "The plenoptic function and the elements of early vision", In M. Landy and J. A. Movshon, editors, *Computation Models of Visual Processing*, MIT press, 1991, pp. 3-20.
- [2] Chen, Shenchang Eric, "QuickTime VR - An Image-Based Approach to Virtual Environment Navigation", *Proceedings of SIGGRAPH 1995*, 1995, pp.29-38.
- [3] Peleg, Shmuel and Joshua Herman., "Panoramic Mosaics by Manifold Projection", *Proceedings of the Conference on Computer Vision and Pattern Recognition 1997*, pp. 338-343.
- [4] Shum, Heung-Yeung and Li-Wei He, "Rendering with Concentric Mosaics", *Proceedings of SIGGRAPH 1999*, pp. 299-306.
- [5] Aliaga, Daniel and I. Carlbom, "Plenoptic Stitching: A Scalable Method for Reconstructing 3D Interactive Walkthroughs", *Proceedings of SIGGRAPH 2001*, pp. 443-450.
- [6] Rogers, A.S, "An introduction to groupware and CSCW", *BT Technology Journal*, 1994, pp. 7-11.
- [7] Greg Johnson, "Collaborative Visualization", *ACM SIGGRAPH - Computer Graphics*, 1998, pp. 8-11.
- [8] Sheng Feng Li, Quentin Stafford-Fraser, Andy Hopper, "Integrating Synchronous and Asynchronous Collaboration with Virtual Networking Computing", *Proceedings of the First International Workshop on Intelligent Multimedia Computing and Networking*, Atlantic City, USA, 2000, pp. 717-721.
- [9] Wood JD, Wright H, Brodlie KW. In Earnshaw R , Vince J and Jones H (eds), "CSCV - Computer Supported Collaborative Visualization", *Visualization and Modelling Academic Press*, 1995, pp.13-25.

- [10] J.Clucas, "Interactive Visualization of Computational Fluid Dynamics Using Mosaic", Proceedings Second International WWW Conference '94, Chicago, 1994, <http://www.nas.nasa.gov/Software/FAST/FASTtreks/paper.html>.
- [11] Johnson, Greg and Steve Mock, "The San Diego Supercomputer Center presents: collaborative AVS", <http://www.sdsc.edu/PET/scivis/page01.html>.
- [12] R. B. Haber, D. A. McNabb." Visualization Idioms: A Conceptual Model for Scientific Visualization Systems", Visualization in Scientific Computing IEEE, 1990, pp. 74-93.



Yin Runmin is a PhD student in Beijing University of Aeronautic and Astronautic from 2003 to now. He received his BS in Industry Automation from the Beijing Institute of closing technology, Beijing China in 2001. His research interests include Virtual reality, image-based rendering, image and video analysis and editing, distributed collaborative visualization and simulation.