

X-Ray Intensity Measurement Using Frequency Output Sensor for Computed Tomography

R. M. Siddiqui, D. Z. Moghaddam, T. R. Turlapati, S. H. Khan, and I. Ul Ahad

Abstract—Quality of 2D and 3D cross-sectional images produced by Computed Tomography primarily depend upon the degree of precision of primary and secondary X-Ray intensity detection. Traditional method of primary intensity detection is apt to errors. Recently the X-Ray intensity measurement system along with smart X-Ray sensors is developed by our group which is able to detect primary X-Ray intensity unerringly. In this study a new smart X-Ray sensor is developed using Light-to-Frequency converter TSL230 from Texas Instruments which has numerous advantages in terms of noiseless data acquisition and transmission. TSL230 construction is based on a silicon photodiode which converts incoming X-Ray radiation into the proportional current signal. A current to frequency converter is attached to this photodiode on a single monolithic CMOS integrated circuit which provides proportional frequency count to incoming current signal in the form of the pulse train. The frequency count is delivered to the center of PICDEM FS USB board with PIC18F4550 microcontroller mounted on it. With highly compact electronic hardware, this Demo Board efficiently reads the smart sensor output data. The frequency output approaches overcome nonlinear behavior of sensors with analog output thus un-attenuated X-Ray intensities could be measured precisely and better normalization could be acquired in order to attain high resolution.

Keywords—Computed tomography, detector technology, X-Ray intensity measurement.

I. INTRODUCTION

COMPUTED tomography (CT) is a prevailing tool for production of 2D and 3D cross sectional images of an object. CT is being successfully employed in industry for nondestructive evaluation (NDE) and in health care as a medical imaging tool for production of tomographic images of specific patient body areas. In biomedical engineering, CT scan is used for various therapeutic and diagnostic procedures. The 3D cross sectional image reconstruction in CT is acquired by calculating attenuation coefficient of the object being examined. Attenuation coefficient is primarily a function of un-attenuated (primary) X-Ray intensity and attenuated (secondary) X-Ray intensity. Secondary X-Ray intensity is detected by flat panel scintillating detector. However the measurement of primary intensity is done through the uncovered areas (edges) of the scintillating detector [1]. This

Rafay Mehmood Siddiqui and Danial Zooroufchian Moghaddam are with the Biomedical Engineering Department, University of Bern, Switzerland (e-mail: bmengr@gmail.com, dan_zorouf@hotmail.com).

Tirumaleswara Rao Turlapati is with the University of Applied Sciences in Western Switzerland, Switzerland (e-mail: tr45bme@gmail.com).

Sana Hyder Khan and Inam Ul Ahad are with the Biomedical Engineering Department, Sir Syed University of Engineering and Technology, Karachi, Pakistan (e-mail: sanahyder@gmail.com, engrinam@gmail.com).

method is prone to errors as the same area is being exposed to scattered radiations and secondary intensity. The exposure of primary, secondary and scattered radiation at same area cause noisy X-Ray intensity detection, induce errors in attenuation coefficient calculation. Consequently these errors cause degradation of reconstructed images. In order to combat these errors, an X-Ray intensity monitoring device has been developed our group [2]. This system consists of a smart sensor which is placed before the testing object and a virtual system which acquires and transmits data to display screen. In this way, direct measurements of primary intensity have been performed with interruption of scattered radiation and secondary intensity. For this system, various sensors were developed which consist of different scintillation materials and various photodiodes in order to detect incoming X-Ray intensity [3]–[6]. These smart sensors provide a proportional signal in the form of current in response to incident electromagnetic rays. Since the output of the sensors is analog due to noise and analog to digital conversion (ADC), their linearity and operating ranges are limited. Comparatively considering frequency as the sensor output signal leads to increased linearity, wide operating range and lossless data transmission as no ADC required. In this work, previously developed X-Ray intensity monitor design is optimized by introducing frequency sensor and related hardware changes. For X-Ray intensity sensor construction TSL230 programmable light to frequency converter from Texas Advanced Optoelectronic Solutions is selected. TSL230 is coupled with scintillation material, thus X-Ray radiations convert into light and then into proportional frequency signal. A readout unit is designed using PICDEM FS USB Board. This unit is interfaced with Personal Computer (PC) via USB and measured intensities are displayed on HyperTerminal window.

II. MATERIALS AND METHODS

Fig. 1 shows the general description of the construction of the system designed for X-Ray intensity measurement. The X-Ray radiations strike scintillating material and convert into visible light photons. Cesium Iodide is used as scintillation material due to its high performance. Visible light falls on the photodiode array of TSL 230, which generate a flow of charge (current) in response to striking light photons. This current signal is delivered to integrated Current-to-Frequency converter in TSL230 resulting in frequency output in the range of 1 Hz – 1.2 MHz as per the configuration. This measured frequency signal is directed to timer port of the PIC18F4550

microcontroller mounted on PICDEM FS USB Board. Microcontroller counts administered frequency signal pulses. Another timer simultaneously measures the time period. This gives the frequency count of the incident X-Ray intensity on smart sensor. Once the frequency count is calculated, with the

help of Universal Serial Bus, it is displayed on HyperTerminal window. Frequency count on the HyperTerminal window can be displayed continuously as per requirement of Non-Destructive Testing imaging.

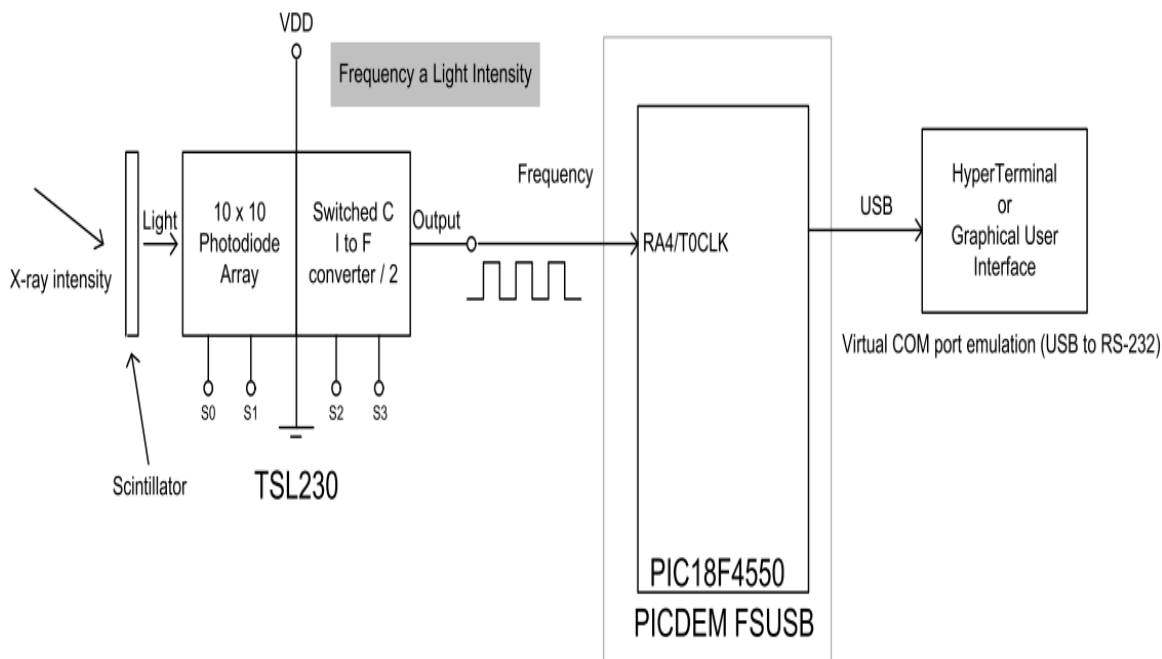

Fig. 1 Block diagram of X-Ray Io monitor device

III. RESULTS AND DISCUSSION

The Texas Advanced Optical Systems (TAOS) TSL230 consisted of a series of photodiodes aligned in array format. The output of TSL230 is principally a square wave. The frequency of this output wave is proportional to incident light exposed on the surface of the sensor. TSL230 is capable of measuring any light intensity due to provision of three level sensitivity.

In addition to that, an off state level is also available. The frequency band provided by this sensor ranges from 1Hz to 1MHz. The high frequency output is not measured by slower microcontroller; therefore frequency division provision is available in setting up the sensor for measuring incoming light intensity.

Since the room light may alter the detection of incident light on the photodiode by scintillator, the sensor is completely covered using an aluminum foil. The measurements are taken at the HyperTerminal window with no exposure of X-Ray intensity on an aluminum foil covered sensor. The HyperTerminal display zero counts showing isolation from the external environment as shown in Fig. 3. This small experiment somehow validates the sensor and system operation.

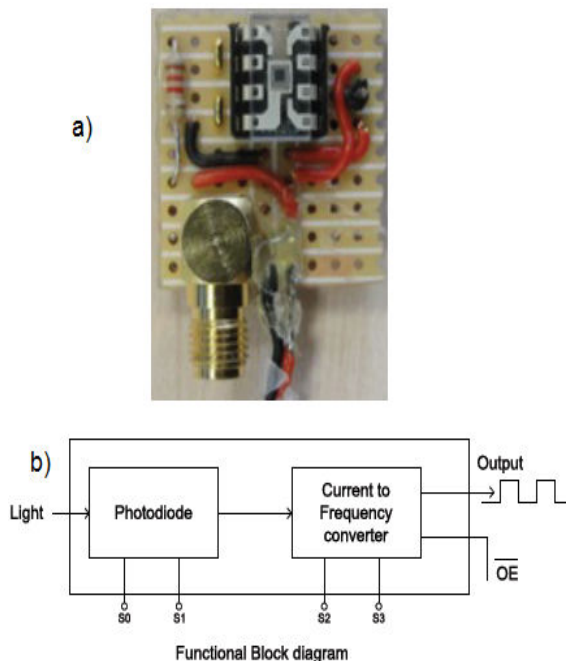

Fig. 2 a) TSL 230 Sensor b) Functional Block diagram of TSL 230

Once the instrument verified to be working for light intensity detection, aluminum foil is removed and X-Ray sensor is placed before the object being tested. Aluminum block is used as an object. X-Ray intensity measurements are recorded at constant X-Ray tube voltage and varied tube current as shown in Fig. 4. The output from the sensor can be displayed on digital oscilloscope and HyperTerminal window. The comparison between the two displays is helpful for verification of data processing and transmission by the microcontroller.

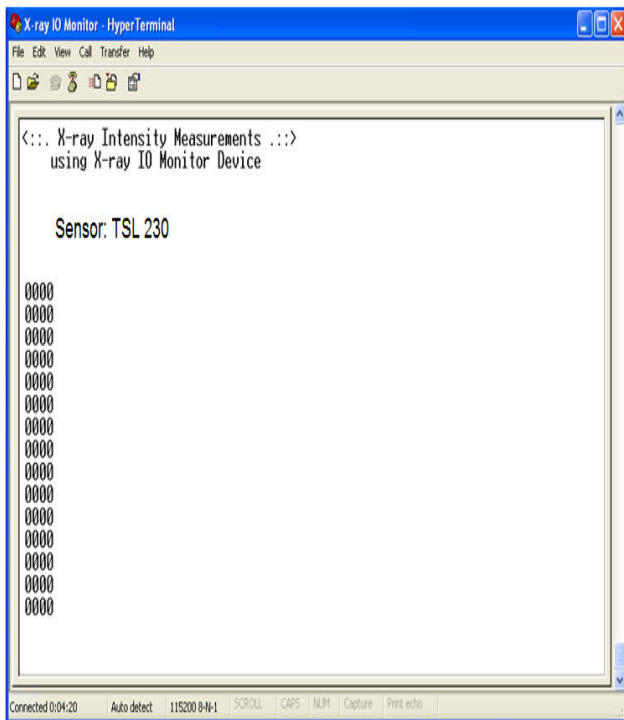

Fig. 3 Frequency output of TSL 230 sensor covered with aluminum foil

IV. NEW ADVANCEMENTS

Already developed X-Ray Io (intensity) monitoring device used photodiode based X-Ray sensors which produce output in the form of analog current. This process is prone to errors due to noisy data transmission and analog to digital conversion. In this study, X-Ray Io device design is optimized by introducing sensor with a frequency output. This technique doesn't require an analog to digital conversion and inherent noise and offset are eliminated by digital pulse train which provides noiseless data transmission. The hardware of the virtual instrument is also optimized for frequency input. This device can be integrated with any Computed Tomography (CT) machine and can interface with any personal computer.

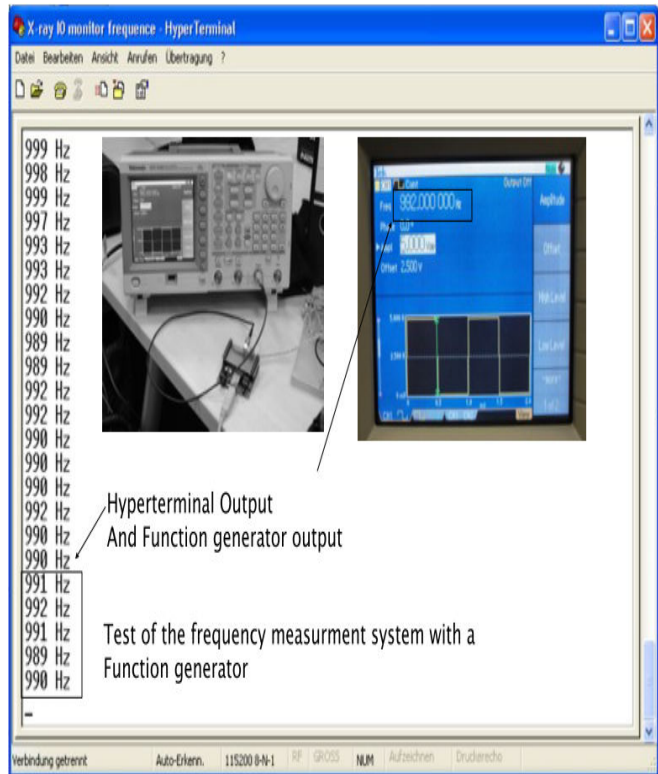

Fig. 4 Primary X-Ray intensity measurements on HyperTerminal window and digital oscilloscope

V. CONCLUSION

Primary (un-attenuated) X-Ray intensities coming from the X-Ray tube of a CT machine are measured using X-Ray Io monitoring device. This device consists of sensor with frequency output and a virtual instrument for acquisition and transmission of data. The behavior of tube parameters can be monitored in real time. A primary object of this system is to detect primary intensity precisely for calculation of attenuation coefficient. Accurate attenuation coefficient provides good quality images. Beside the improvement of image quality, X-Ray Io monitor device can also be used efficiently for monitoring of the fluctuations which may present in the X-Ray generation. This may lead to the characterization of X-Ray tube and detector.

REFERENCES

- [1] J. D. Bronzino, *Biomedical Engineering Handbook, Volume I*. CRC Press, 1999, p. 1656.
- [2] R. Siddiqui, I. U. Ahad, S. Amir, B. Aklan, and T. Uddin, "X-Ray IO Monitor Device for Primary Intensity Measurement in Computed Tomography (CT) Scanner," in *4th International Conference on Biomedical Engineering in Vietnam*, 2013, vol. 40, pp. 33–36.
- [3] I. U. Ahad, R. M. Siddiqui, and Z. Islam, "Cesium Iodide and Scheelite Coupled X-Ray Sensors Characterization for Industrial Applications of Computed Tomography (CT) as Non Destructive Testing (NDT)," in *Imaging and Signal Processing in Health Care and Technology / 772: Human-Computer Interaction / 773: Communication, Internet and Information Technology*, 2012.
- [4] R. M. Siddiqui, I. U. Ahad, S. S. Zehra, and Anurag, "Characterization of X-Ray Sensors and Io Monitor Device Testing for Primary and

Secondary Intensities Measurement,” in *4th International Conference on Biomedical Engineering in Vietnam IFMBE Proceedings*, 2013, vol. 40, pp. 37–40.

- [5] I. U. Ahad, R. Siddiqui, B. Aklan, and S. Zehra, “Scheelite Coupled Photodiode X-Ray Sensor Designing and Characterization,” in *4th International Conference on Biomedical Engineering in Vietnam*, 2013, vol. 40, pp. 41–44.
- [6] R. M. Siddiqui, I. U. Ahad, B. Aklan, A. Anurag, Z. Islam, S. S. Zehra, and H. S. J. Soto, “X-Ray Io Monitor Measuring Device for X-Ray Intensity for Industrial Testing Applications,” in *Biomedical Engineering / 765: Telehealth / 766: Assistive Technologies*, 2012.