

Dynamic Modeling of Intelligent Air-Cushion Tracked Vehicle for Swamp Peat

Altab Hossain, Aatur Rahman, A. K. M. Mohiuddin, and Yulfian Aminanda

Abstract—Modeling of the dynamic behavior and motion are renewed interest in the improved tractive performance of an intelligent air-cushion tracked vehicle (IACTV). This paper presents a new dynamical model for the forces on the developed small scale intelligent air-cushion tracked vehicle moving over swamp peat. The air cushion system partially supports the 25 % of vehicle total weight in order to make the vehicle ground contact pressure 7 kN/m^2 . As the air-cushion support system can adjust automatically on the terrain, so the vehicle can move over the terrain without any risks. The spring-damper system is used with the vehicle body to control the air-cushion support system on any undulating terrain by making the system sinusoidal form. Experiments have been carried out to investigate the relationships among tractive efficiency, slippage, traction coefficient, load distribution ratio, tractive effort, motion resistance and power consumption in given terrain conditions. Experiment and simulation results show that air-cushion system improves the vehicle performance by keeping traction coefficient of 71% and tractive efficiency of 62% and the developed model can meet the demand of transport efficiency with the optimal power consumption.

Keywords—Air-cushion system, ground contact pressure, slippage, power consumption.

I. INTRODUCTION

THE transportation operation in agriculture over the swamp peat terrain is considered as the biggest issue of the world. With increasing demands to the wide application of off-road vehicles over soft terrain and swamp peat such as agriculture, forestry, construction and the military, there is a need to increase the knowledge about intelligent air-cushion system of swamp peat vehicle. The performance of air-cushion tracked vehicles travelling in a straight motion with uniform ground pressure distribution is well understood. However, prepared or unprepared tracks inherently have uneven profile for situations of vehicles travelling on deformable road surfaces. The vehicle responses during off-road operation are dependent on the road conditions and vehicle parameters such

as clearance height, road roughness, vehicle speed, vehicle weight, and air-cushion pressure [1-3]. Many research works have been carried out and different types of vehicles are introduced to solve the transportation problems on moderate peat terrain [4-7]. But still no one offers any vehicle on low bearing capacity swamp peat terrain in Malaysia. The developed small scale vehicle could be useful for transporting the palm oil fresh fruit bunches over the swamp peat. A hybrid vehicle which combines intelligent air-cushion system with a driving mechanism has been proven to be an efficient solution for a heavy duty vehicle on severe working conditions [8]. However, the use of commercial intelligent air-cushion tracked vehicles to test the vehicle parameters is limited due to the difficulties in varying parameters as well as the control of the air-cushion pressure. A small scale hybrid electrical air-cushion tracked vehicle (HEACTV) was therefore developed which offered the possibility to vary vehicle parameters in simple way based on low bearing capacity of peat swamp [9]. The study has been focused based on the bearing capacity of the peat swamps in Sarawak that has been found as 7.7 kN/m^2 and it has poor trafficability due to the presence of submerged and undecomposed and partially decomposed materials such as woods, stumps and logs in the soil, that impede the movement of a farm workers and machinery in the field. Other important properties are the very high ground water table, and low bulk density [10-12]. The integrated mechanics had been introduced to understand the terrain nature and mechanics of track-terrain interaction and the interaction of air-cushion supporting system-terrain [13]. The overall system is linked with the loading of the vehicle dependent on the air-cushion pressure, ground contact forces and ground contact pressures. Therefore, the focus of the current study is on dynamical model for the developed intelligent hybrid electrical air-cushion tracked vehicle (HEACTV) which is used for transportation operation of agricultural and industrial goods on swamp peat.

II. VEHICLE MODELING

A. Description of Model

The vehicle configuration has been shown in Fig. 1 which is generally composed of two parts, one is the propulsion part

A. Hossain is with the Mechanical Engineering Department, International Islamic University Malaysia. He is also with the Mechanical Engineering Department, Universiti Industri Selangor (Tel: 603-3280-5122; Fax: 603-3280-6016; e-mail: altab75@unisel.edu.my).

A. Rahman is with the Mechanical Engineering Department, International Islamic University Malaysia (e-mail: arat@iiu.edu.my).

A.K.M.Mohiuddin is with the Mechanical Engineering Department, International Islamic University Malaysia (e-mail: mohiuddin@iiu.edu.my).

Y. Aminanda is with the Mechanical Engineering Department, International Islamic University Malaysia (e-mail: yulfian@iiu.edu.my).

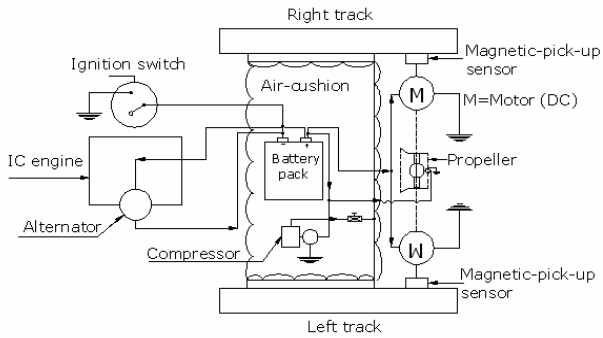

Fig. 1. Vehicle power transmission system.

and the other is air cushion part. The track mechanism is used as the driving system to overcome the rolling motion resistance and the air cushion system is used to increase the floatation capacity of the vehicle. The driving force is provided to each of the tracks by an individual DC motor. The air-cushion system of this vehicle was designed in such a way that it would not slide on the terrain with the vehicle movement. It only supports the partial load of the vehicle once the vehicle sinkage is closed to 70 mm and makes the vehicle ground contact pressure 7 kN/m². The additional thrust (or tractive effort) is provided to the vehicle by using a propeller to overcome the drag motion resistance of the air-cushion system. As the terrain is unprepared and different types of decomposed materials are on the terrain, the air-cushion system was protected by using a novel design auto adjusting supporting system using aluminium plate. It can adjust the air-cushion system on the terrain automatically by absorbing its longitudinal displacement with two horizontally attached shock absorbers and vertical displacement with four vertically attached springs [13-14].

As for simplification, there are some assumptions are made based on the physical models in order to allow the appropriate mathematical simplifications. The assumptions are:

- (i) The center of gravity of the vehicle body is located on the longitudinal axis of the vehicle.
- (ii) The swamp terrain surface is uniform before vehicle entering.
- (iii) Track-terrain contact area and air-cushion-terrain contact area are with uniform normal pressure distribution.
- (iv) The deformations of four vertical springs and dampers are same.
- (v) The simplest dynamics occurs when the vehicle moves with low speed over surface disturbances.

B. Theoretical Models of Dynamics

For the convenience of modeling, the forces acting on the vehicle for uniform ground pressure distribution (UGPD) and the dynamic behavior of the air cushion system are shown in the Fig. 2. The work has been considered with a total vehicle weight W , track size including track ground contact length L , width B , pitch T_p , grouser height H , rear sprocket R_{rs} , road-wheel R_r (here R_{fi} is same with R_r since first road wheel acts like as front idler), and height of the center of gravity of

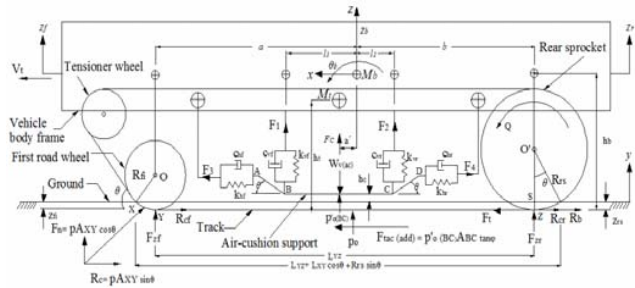

Fig. 2. Forces acting on the air cushion tracked vehicle for UGPD.

vehicle body h_b traversing under traction on a swamp peat terrain at a constant speed of v_t as soon as applying driving torque Q at the rear sprocket. The reaction pressures at the first road wheel p_{fi} , main straight part p_o , and rear sprocket p_{rs} , and the sinkage of the front wheel z_{fi} and the sinkage of the rear sprocket z_{rs} are revealed same value since center of gravity of the vehicle body is located on the longitudinal axis of the vehicle.

C. Vertical Dynamics

In this vehicle's mechanical system, the terrain surface is assumed to be horizontal and choose the x -axis horizontally, positive to the left (towards the front of the vehicle) as in the direction of vehicle motion [13-14]. The positive z -axis is vertically upwards. Point Y and Z are the two contact points of front road wheel and rear sprocket with the ground.

Ground Contact Forces

Constructing the torque balance at the rear contact point (point Z) and front one (point Y) in Fig. 2, the ground contact forces of first road wheel and rear sprocket F_{zf} and F_{zr} for the vehicle dynamic condition can be obtained as follows:

$$\sum M_Z = \sum (M_k)_Z;$$

$$F_{zf} = \frac{1}{2L_{YZ}} [M_b g b - M_b a_x h_b - 2M_t a_x h_t + M_t g L_{YZ} - F_c (a' + b)] \quad (1)$$

$$\sum M_Y = \sum (M_k)_Y;$$

$$F_{zr} = \frac{1}{2L_{YZ}} [M_b g a + M_b a_x h_b + 2M_t a_x h_t + M_t g L_{YZ} - F_c (a - a')] \quad (2)$$

where M_b is the mass of vehicle body in kg, M_t is the mass of one track in kg, a_x is the longitudinal acceleration in m/s², h_b is the height of center of gravity of vehicle body in m, h_t is the height of center of gravity of track in m, a is the distance between the first road wheel and the center of gravity of vehicle body in m, b is the distance between the rear sprocket and the center of gravity of vehicle body in m, L_{YZ} is the length of the track in contact with terrain (Wheel base) in m, a' is the distance between the point of application of air cushion force and the center of gravity of vehicle body in m, l_1 is the distance between the front spring-damper and the center of gravity of vehicle body in m, l_2 is the distance between the rear spring-damper and the center of gravity of vehicle body in m, F_c is the air cushion force (lift force) in N, and g is acceleration due to gravity in m/s².

Air Cushion Force

According to previous studies, it has been shown that load distribution affects total power consumption significantly. Load distribution ratio is defined as

$$\delta = \frac{W_{v(ac)}}{W} \quad (3)$$

where $W_{v(ac)} = F_c$ is the weight supported by air cushion force in N and W is the total weight of the vehicle in N. In the expression of $W_{v(ac)}$, F_c is the air-cushion force (lift force), which can be expressed by $F_c = p'_{o(BC)} A_{BC}$, where p'_o is the ground nominal pressure which could exist due to the transfer load of the vehicle to the air-cushion system in N/m^2 , A_{BC} is the contact area of the air-cushion support system, and W is the total weight of the vehicle.

D. Longitudinal Dynamics

The equation of motion along the longitudinal axis of the vehicle is given by

$$+ \leftarrow \sum F_x = ma_x; \quad Ma_x = 2F_t - R_t \quad (4)$$

where M is the vehicle mass in kg, a_x is the longitudinal acceleration of the vehicle in m/s^2 , F_t is the tractive effort (traction force) that one track can get from terrain in N, and R_t is the total travelling resistance in N.

Based on the established mathematical model, the terrain driving force (traction force) F_t in N is given by [13-14],

$$F_t = (A_t c + W_t \tan \varphi) \left[\frac{K_w}{iL} e^i - \left(1 + \frac{K_w}{iL} \right) \exp \left(1 - \frac{iL}{K_w} \right) \right] + R_{drag} \quad (5)$$

where, $A_t = (L_{XY} \cos \theta + L_{YZ} + R_{rs} \sin \theta)(2B)$

$L = (L_{XY} \cos \theta + L_{YZ} + R_{rs} \sin \theta)$ and $L_{XY} = \frac{z}{\sin \theta}$

In Eq. (5), L is the ground contact length of the track in m, B is the width of the track in m, A_t is the area of the track ground contact part in m^2 , W_t is the vehicle load supported by the track system in N, c is the cohesiveness in N/m^2 , φ is the terrain internal friction angle in degrees, K_w is the shear deformation modulus of the terrain in m, i is the slippage of the vehicle in percentage, R_{drag} is the drag motion resistance which is developed due to the sliding of the air-cushion system over the terrain in N and θ is the angle between the track of the 1st road-wheel to tensioned wheel and to the ground in degrees.

In this study, the intelligent air-cushion tracked vehicle for swamp peat is designed mainly as a low speed heavy-duty off road vehicle and assuming the vehicle on a level terrain surface, the motion resistances from aerodynamics and track belly drag component in the computations of the total motion resistance can be ignored. Hence, the total resistance R_t can be assumed to only contain the motion resistance of the vehicle due to terrain compaction R_c , inner resistance R_{in} , and the dragging motion resistance R_{drag} are given by [13-14],

In a particular soil condition, the compaction resistance R_c in N is given by

$$R_c = 2B \left(\frac{k_p z^2}{2} + \frac{4}{3D_{hlc}} m_m z^3 \right) \quad (6)$$

$$\text{Where, } z = \frac{-\left(\frac{k_p D_{hlc}}{4m_m} \right) \pm \sqrt{\left(\frac{k_p D_{hlc}}{4m_m} \right)^2 + \frac{D_{hlc}}{m_m} p'}}{2}$$

$$D_{hlc} = \frac{4BL}{2(L+B)} \text{ and } P' = \frac{W_t}{(L)(2B)} = \frac{W - p'_o A_C}{2BL}$$

In Eq. (6), p' is the normal pressure of the vehicle in N/m^2 and z is the sinkage in m, m_m is the surface mat stiffness in N/m^3 , k_p is the underlying peat stiffness in N/m^3 , D_{hlc} is the track hydraulic diameter in m when air cushion touches the ground, A_C is the air-cushion effective area in m^2 , W is the total weight of the vehicle in N, W_t is the weight supported by the two tracks (weight of driving system or weight supported by propulsion system) in N, and p'_o is the cushion pressure in N/m^2 .

The motion resistance of the vehicle due to internal friction losses, deeply affected by the track and the speed of the vehicle, R_{in} in N is computed by [1],

$$R_{in} = \left(\frac{W - W_{v(ac)}}{1000g} \right) [222 + 3v] \quad (7)$$

where v is the vehicle theoretical speed in km/h, g is the gravitational acceleration in m/s^2 , and $W_{v(ac)}$ is the weight supported by the air-cushion in N and is equal to $W_{v(ac)} = p'_o A_C$.

The drag motion resistance R_{drag} of the air-cushion system in N is given by

$$R_{drag} = p'_o A_C \tan \varphi \quad (8)$$

Depending on Eqns. 6-8, the total travelling resistance R_t in N is,

$$R_t = R_c + R_{in} + R_{drag} = 2B \left(\frac{k_p z^2}{2} + \frac{4}{3D_{hlc}} m_m z^3 \right) + \left(\frac{W - W_{v(ac)}}{1000g} \right) [222 + 3v] + p'_o A_C \tan \varphi \quad (9)$$

where, W is the total weight of the vehicle in N, and φ is the terrain internal friction angle in degrees.

E. Vertical force balance for vehicle body

There is a force balance among ground contact forces, spring-damper forces, air-cushion force and the weight of the vehicle body. Supposing the front vertical spring-dampers deformation is the same with vertical rear spring-dampers by current specific configuration in the vehicle (Fig. 2). So the final vertical force balance is

$$+\uparrow \sum F_y = 0;$$

$$F_{zr} + F_{zf} + 2F_1 + 2F_2 + F_c - M_b g = 0 \quad (10)$$

where F_{zf} is the ground contact force of first road wheel in N, F_{zr} is the ground contact force of rear sprocket in N, Δz is the deformation of the spring and damper in m with stiffness k and damping coefficient c respectively, F_1 and F_2 are the spring-damper forces for the front and rear suspension in N, respectively, F_c is the air-cushion force (lift force) in N, and M_b is the mass of vehicle body in kg.

F. Volume flow balance

Under steady-state conditions, the air being pumped into the chamber by air compressor should equal to the air flow out of the chamber under the peripheral gap. The total volume flow of air from the cushion, Q in m^3/s is,

$$Q = Av_c = h_c L_c D_c v_c = h_c L_c D_c \sqrt{\frac{2p'_o}{\rho}} \quad (11)$$

where h_c is theoretical clearance height in m, L_c is the perimeter of air-cushion in m, D_c is the discharge coefficient, ρ is the air density in kg/m^3 and p'_o is the air-cushion pressure in N/m^2 .

G. Total Power Consumption

When the vehicle with a constant load is subjected to external disturbances, such as uneven or slope of terrain surfaces, the clearance height of the vehicle and the required power on the tracks will change. However, the load distribution between driving system and air cushion pressure also changes, and thus total power requirement changes. Since the total weight is supported partly by the air-cushion and partly by driving tracks, the total power consumption is due to propulsion of tracks and compressor for air-cushion.

The total power requirement P of the vehicle includes the power for air cushion system P_c and the power for driving system (propulsion system) P_d , which is given by:

$$P = P_c + P_d \quad (12)$$

Where P_c is the power consumed by air-cushion used to support the weight of the vehicle body in W and P_d is the power consumed by driving system (propulsion system) in W used to overcome the traveling resistance and maintain normal driving state.

Power Demand for Air-Cushion System

The power demand for air-cushion system P_c in W can be expressed by the following equation,

$$P_c = p'_o Q$$

Where Q is the volume flow of air from compressor in m^3/s , and p'_o is the cushion pressure in N/m^2 .

Power Demand for Propulsion System

The power demand for propulsion system P_d in W can be expressed by the following equation:

$$P_d = R_t v_t$$

Where R_t is the total travelling resistance in N, and v_t is the vehicle theoretical speed in m/s.

Total Power Consumption and Optimum State

Based on Eq. (12), the total vehicle power requirement P is rewritten as below,

$$\begin{aligned} P &= P_c + P_d \\ &= h_c L_c D_c \left(\frac{2}{\rho}\right)^{\frac{1}{2}} (p'_o)^{\frac{3}{2}} + \left[2B \left(\frac{k_p z^2}{2} + \frac{4}{3D_{hc}} m_m z^3\right)\right] v_t \\ &+ \left[\left(\frac{W - p'_o A_c}{1000g}\right) [222 + 3v] p'_o A_c \tan \phi\right] v_t \end{aligned} \quad (13)$$

In Eq. (13), P_c is mainly used to fully or partially support main proportion weight of the vehicle body, P_d is to overcome the vehicle travelling resistance and to maintain the normal driving state. For a particular soil condition, the existence of an optimal load distribution ratio, which results in minimum total power consumption for the vehicle, could be determined. So for Eq. (13), taking partial derivative of P with respect to p'_o and having resultant equation equal to zero, i.e.

$$\frac{\partial P}{\partial p'_o} = 0 \quad (14)$$

The optimal cushion pressure p'_o can be calculated for given soil condition and vehicle speed. For an intelligent air cushion tracked vehicle with a given load, the optimal air-cushion pressure is relevant to soil condition, vehicle speed and clearance height. All these factors will affect power consumption and operation performances.

III. AIR-CUSHION DYNAMICS

The interactions between the ground surface, air supply system, and skirt, and their effect on the dynamics of an IACTV are quite complex. The air-cushion serves as the primary coupling mechanism between the ground surface and the IACTV. The study has been considered with the analysis of the air-cushion tracked vehicle, both from a perspective of (i) a heave restoring on fixed surface and (ii) heave restoring on free surface by using adiabatic pressure-volume representation.

A. Heave Restoring on Fixed Surface

The heave restoring elements of the air-cushion vehicle is considered in this study from a perspective of a static adiabatic pressure-volume representation, and solution to the spring-damper equation.

Adiabatic Gas law Representation

The adiabatic gas law gives a static relationship between pressure and volume such that

$$p_i V_i^\gamma = p_f V_f^\gamma$$

Considering an air-cushion cavity with constant length (L_c) and width (B_c), we get

$$p_i h_i^\gamma = p_f h_f^\gamma \quad (15)$$

Here, volume, $V = \oint(h)$ as area, $A = \text{constant}$, p_i is the initial pressure in Pa, V_i is the initial volume of air-cushion in m^3 , h_i is the initial height of air-cushion in m, p_f is the final (inflated) pressure in the cushion in Pa, and h_f is the final height after air-cushion expanded in m as shown in Fig. 3.

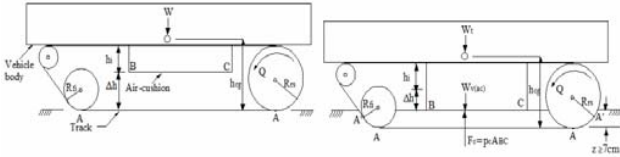

Fig. 3. Depiction of the air cushion inflation system.

Letting $h_f = h_i + dh$, where dh is the change of height (Fig. 3), and using the first term of a binomial expansion for $dh \ll h_i$, Eq. (15) is rewritten as

$$p_i h_i^\gamma = p_f h_i^\gamma \left(1 + \gamma \frac{dh}{h_i} \right)$$

$$\Rightarrow p_f - p_i = \frac{-p_f}{h_i} \gamma dh$$

The upward force (lift) due to the pressure difference between the inside and outside pressure is

$$F_c = (p_f - p_i) B_C L_C = \frac{-p_f \gamma B_C L_C}{h_i} dh = -k_C dh \quad (16)$$

Where the specific heat ratio for air is taken as the constant $\gamma = 1.4$.

The final pressure p_f is the pressure required to support the partial weight of the vehicle as

$$p_f = p_i + \frac{W_{v(ac)}}{B_C L_C} \quad (17)$$

Here, spring constant for the air-cushion, k_C is estimated through the adiabatic gas law as

$$k_C = \frac{p_f \gamma A_C}{h_i} = \frac{p_f \gamma B_C L_C}{h_i} \quad (18)$$

The static compression distance and the cushion natural frequency for the air-cushion tracked vehicle can thus be predicted. The compression distance is given by

$$\Delta z = \frac{W_{v(ac)}}{k_C} \quad (19)$$

While natural frequency with a ground surface is given by

$$f = \frac{1}{2\pi} \sqrt{\frac{k_C}{M_{v(ac)}}} \quad (20)$$

B. Heave Restoring on Free Surface

The system is considered where the air-cushion track vehicle is on a free surface, and partially displacing water due to the cushion pressure. The free surface displacement is considered as a second spring system which could be incurred due to the cushion action of the water. Therefore, this cushion action (spring force) will be series with the cushion spring as shown in Fig. 4.

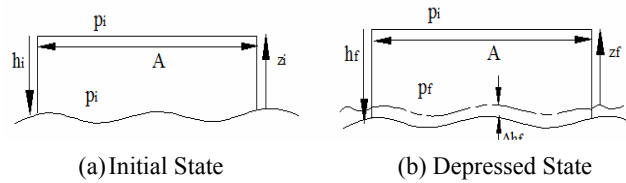

Fig. 4. Depiction of the air cushion system forcing a surface

Fig. 4 shows the cushion on the free surface in both the initial and depressed state. Here, h represents the height of the air-cushion, z represents the distance from the mean free surface to the top of the cushion, and A represents the surface area of both the top and bottom boundaries of the cushion. Since the vehicle travels on the confined (close) area in where there is no drainage system, so the vehicle is floated rather than sink due to the buoyancy effect.

C. Static Analysis of the Coupled System

With the load supported by the air-cushion as $W_{v(ac)}$, static equilibrium for support of the vehicle in depressed state gives

$$(p_f - p_i) A = W_{v(ac)} = M_{v(ac)} g$$

While the free surface depression due to the cushion pressure is

$$(p_f - p_i) A = \rho_w g (h_f - z_f) A$$

Considering the pressure forcing at the free surface to be forcing a spring, we can find the spring constant

$$F_{\text{impact}} = (p_f - p_i) A = k_F dh = \rho_w g (h_f - z_f) A$$

$$\Rightarrow k_F = \rho_w g A \quad (21)$$

In the static sense, the air-cushion and free-surface could be considered to be two springs connected in series as shown in Fig. 5.

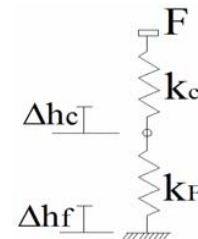

Fig. 5. Diagram of the series spring effect of the air-cushion and free-surface response

Here, Δh_C is considered to be the compression of the cushion spring and Δh_F to be the compression of the free-surface under the external force F . Static equilibrium gives

$$k_C \Delta h_C = k_F \Delta h_F = F$$

from which the total effective spring constant, k_T could be obtained as,

$$F = k_T (\Delta h_C + \Delta h_F) = k_F \Delta h_F$$

$$\Rightarrow \frac{1}{k_T} = \frac{1}{k_C} + \frac{1}{k_F} \quad (22)$$

The ratio between the static displacement of the free-surface and the static compression distance of the air-cushion is computed as

$$\frac{\Delta h_F}{\Delta h_C} = \frac{k_C}{k_F} \text{ and thus the static cushion displacement, } \Delta h_C$$

could be predicted.

The total heave displacement of the hull due to cushion compression and free surface depression would be

$$\Delta z = \Delta h_C + \Delta h_F \quad (23)$$

D. Dynamic Analysis of the Coupled System

When considering the dynamics of the coupled system, the series spring representation does not exactly hold. The issue is with fluid added mass, which is additional inertia for the free-surface spring system, but not for the cushion spring system.

As a first approximation, the added mass is considered to be equal to the displaced fluid mass or the mass supported by the air-cushion. As the free-surface spring is considerably softer than the cushion spring, it contributes more significantly to the total effective spring constant. Thus, the natural response frequency could be predicted based upon the mass supported by the air-cushion, including added mass, and the total system spring constant,

$$f = \frac{1}{2\pi} \sqrt{\frac{k_T}{M_{v(ac)} + M_A}} \quad (24)$$

IV. RESULTS AND DISCUSSIONS

A. Simulation Conditions

The prototype experiments were performed outside on the field of the faculty of Engineering, IIUM at travelling speed 10 km/h and 15 km/h with loading conditions of 2.43 kN and 3.43 kN with and without activating the air-cushion system [9] and some typical results are presented. The vehicle (HEACTV) travelling distance during testing was considered as 50 m and the tests were only carried out on level terrain surfaces so far. To optimize the power consumption of HEACTV and some related physical and mechanical parameters about the HEACTV during experiments are shown in Table 1. Based on the established mechanics and the designed small scale vehicle model, corresponding simulations and performance were carried out.

The developed prototype is presented in Fig. 6 (photo). Steering of this vehicle was achieved by means of an individual switch of the DC motor with a power of 0.50 kW @ 2.94 Nm [8]. The dry weight of the vehicle was considered as 2.43 kN and it was designed mainly for operating a maximum

TABLE I
UNITS FOR MAGNETIC PROPERTIES

Symbol	Parameters	Values	Units
W	Total vehicle load	3433.5	N
L_t	Length of track ground contact	1.00	m
B_t	Width of track ground contact	0.254	m
L_{ac}	Length of the air-cushion	0.80	m
B_{ac}	Width of the air-cushion	0.68	m
h_i	Initial height of the air-cushion	0.30	m
A_C	Air cushion effective area	0.544	m ²
L_C	Air cushion perimeter	2.96	m
v_t	Vehicle theoretical velocity	2.78	m/s
ρ	Air density	1.20	kg/m ³
m_m	Surface mat stiffness	13590	N/m ³
k_p	Underlying peat stiffness	171540	N/m ³

load of 3.43 kN including a 1.00 kN payload over the swamp peat terrain. The total ground contact area of the vehicle was 1.052 m² including 0.544 m² of the air-cushion system. The vehicle was powered by a battery pack comprising eight (8) lead acid batteries, connected in parallel. The vehicle could travel 24 km powered of the single charging battery pack. A small IC Engine power of 2.5 kW @ 4000 rpm was installed on the vehicle to recharge the battery pack with the help of an alternator.



Fig. 6. Developed prototype of air-cushion track vehicle [9]

B. Effect of Slippage on Tractive Efficiency and Traction Coefficient.

The present study is focusing on slippage for maximizing the tractive efficiency and traction coefficient as well. The effects of slippage on the tractive efficiency (TE) and traction coefficient (TC) for the hybrid electrical air-cushion tracked vehicle (HEACTV) are investigated. Fig. 7 and 8 show the relationship between slippage and tractive efficiency and

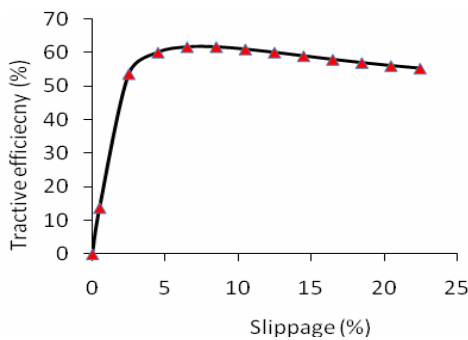

Fig. 7. Effects of slippage on the tractive efficiency

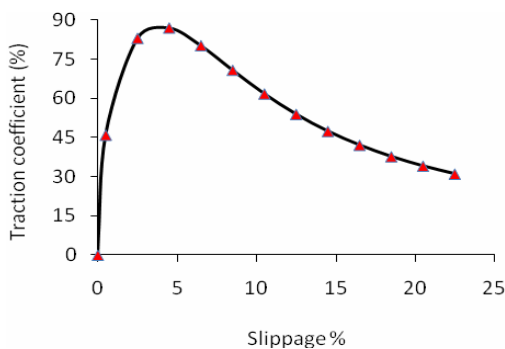

Fig. 8. Effects of slippage on the traction coefficient

traction coefficient respectively. Tractive efficiency is an important criterion to evaluate the trafficability of the vehicle. In Fig. 7, at the maximal tractive efficiency, the corresponding slippage is 8.5 %. It is noticed that as slippage increases from 0, TE increases rapidly; when slippage equals to 8.5 %, the curve reaches its peak of 62 %; then slowly decrease. In starting acceleration case, the actual slippage needs to be controlled at this theoretical value in order to get the maximal TE. When the vehicle is in uniform velocity motion, driving force equals to traveling resistance and so TE equals to 0. In Fig. 8, it can be seen that traction coefficient increases rapidly with the increase of slippage from 0; when slippage equals to 4.5 %, the curve reaches its peak of 87 %; then gradually decrease. When the slippage equals to 8.5 %, the corresponding TC could be obtained as 71 % which makes the vehicle highly potential to operate on the swamp peat terrain [15].

C. Effect of Load Distribution on Tractive Effort, Motion Resistance and Total Power Consumption

For a given soil condition, the required driving force can be predicted with different load distribution levels (defined as the load transferred from the driving system to the air cushion system) for minimizing total power consumption. The effect of load distribution on the tractive effort, motion resistance and total power consumption for the hybrid electrical air-cushion tracked vehicle (HEACTV) are investigated. Fig. 9, 10 and 11 show the relationship between load distribution ratio and

tractive effort, total motion resistance and total power consumption respectively.

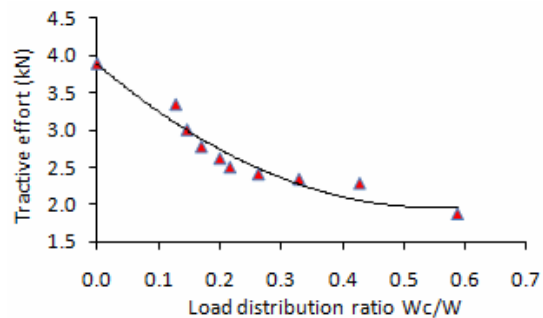

Fig. 9. Effects of load distribution ratio on tractive effort

The variation of tractive effort as a depending on load distribution is shown in Fig. 9 and it is observed that tractive efforts of the vehicle almost gradually decrease with the increase of load distribution from the vehicle to the air-cushion system and it is also found that tractive effort is varied from 1.87 to 3.9 kN. The greatest changes in tractive effort occurred at a load distribution of 0.6 with greater load transfer from vehicle to the air-cushion system. Based on previous research [9, 16], the tractive effort is observed as about 2.5 kN, for the load distribution ratio of 0.2.

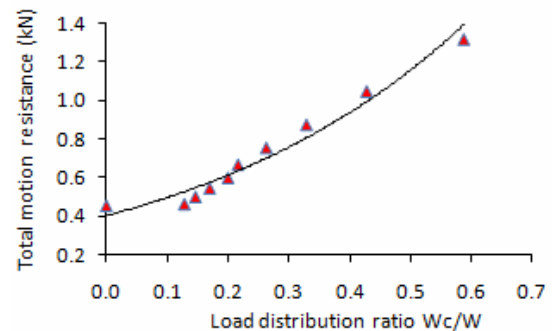

Fig. 10. Effects of load distribution ratio on motion resistance

The variation of total motion resistance of the vehicle is found in the range of 0.45 to 1.32 kN shown in Fig. 10. Lower value of motion resistance and greater value of tractive effort are found due to the additional tractive effort developed by the propeller [9, 17]. Furthermore, air-cushion system is a crucial part for the vehicle which reduces the vehicle motion resistance with reducing the vehicle sinkage. It is observed that the greater load distribution shows higher values of motion resistance due to the dragging motion resistance [18].

Fig. 11 shows the relationship between load distribution ratio and total power consumption. From the Figure, it is observed that the load distribution ratio affects the total power consumption significantly as total power consumption linearly increases with the increase of load distribution ratio. The total power consumption is varied from 1.25 to 8.3 kW. Based on established theoretical model [13] and the designed prototype, corresponding simulation and experimental results were carried out and an optimal load distribution ratio of 0.2 was

obtained which could result in prediction of minimum power consumption of 3.5 kW and it was also supported by [9, 19] for the vehicle loading condition of 3.43 kN. The power consumption of the vehicle was optimized based on the total motion resistance which was mainly for compaction motion resistance and dragging motion resistance and it was explained elsewhere [20].

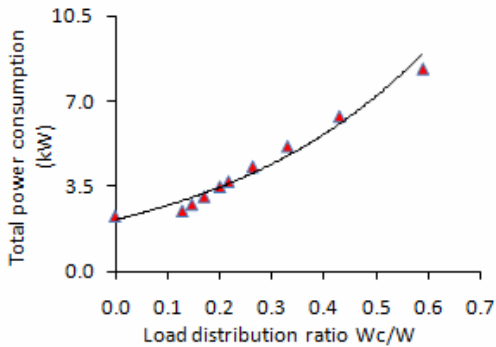

Fig. 11. Effects of load distribution ratio on total power consumption.

V. CONCLUSION

In this paper, a new dynamical model has been developed that incorporates the component of hybrid electrical air-cushion track vehicle. The simulation and experimental results presented in this paper represent the validation of the developed small scale prototype HEACTV. However the conclusions that are made based on the discussion of this study:

1. The developed model can be used to simulate the vehicle tractive performance over the swamp peat terrain.
2. Based on the simulation result the following conclusion could be made:
 - (i) The vehicle load distribution to the air-cushion system would not be too much as the power consumption by the air-cushion drag motion resistance is too high. Other than that the power of the battery pack is too limited.
 - (ii) Air-cushion system of the vehicle makes the vehicle ground contact pressure less than 7 kN/m² with partially supporting the vehicle load as well as makes the vehicle sinkage less than 70 mm.
 - (iii) Traction coefficient and tractive efficiency of the vehicle 71% and 62%, respectively, make the vehicle highly potential to operate on the swamp peat terrain.
 - (iv) Simulation and experimental results of this study demonstrate that the developed model is a useful and effective for the full scale prototype vehicle designer in the development of low bearing capacity tracked vehicles for over swamp terrain operations.

ACKNOWLEDGMENT

The authors are grateful for the support provided by financial assistance from the International Islamic University Malaysia (IIUM) for the overall facilities.

REFERENCES

- [1] J. Y. Wong, Theory of Ground Vehicles, 4th Ed., New York, John Wiley & Sons, Inc., 2008.
- [2] M. G. Bekker, Introduction to Terrain-Vehicle Systems, The University of Michigan Press, Ann Arbor, MI., 1969.
- [3] I. C. MacFarlane, Muskeg Engineering Handbook, University of Toronto Press, Toronto.
- [4] R. Ataur, Y. Azmi, M. Zohadie, D. Ahmad, W. Ishak, Design and development of a segmented rubber tracked vehicle for Sepang peat terrain in Malaysia, *Int. J. Heavy Vehicle Systems*, 12 (3) (2005) 239-267.
- [5] A. Bodin, Development of a tracked vehicle to study the influence of vehicle parameters on tractive performance in soft terrain, *Journal of Terramechanics*, 36 (1999) 167-181.
- [6] H.S. Ooi, Design and development of peat prototype track type tractor. MARDI, Report No. 184, 1996.
- [7] A. Rahman, A.K.M Mohiuddin, H. Altab, Noraini, Irwan, Mobility of the Lpg-30 Wheeled Vehicle on Peat Terrain in Malaysia, 7th International Conference on Mechanical Engineering, ICME 2007, 28-30 December, 2007, Dhaka, Bangladesh.
- [8] L. Zhe, Y. Fan, C.C. Bing, Design of a novel semi-tracked air-cushion vehicle for soft terrain, *In. J. of Vehicle, Design*, 31 (1) (2003) 112-123.
- [9] R. Ataur, A. K. M. Mohiuddin, A.I. Faris, Y. Azmi, A. Hossain, Development of hybrid electrical air-cushion tracked vehicle for swamp peat, *Journal of Terramechanics*, 47 (2010) 45-54.
- [10] R. Ataur, Y. Azmi, M. Zohadie, D. Ahmad, W. Ishak, Mechanical properties in relation to mobility of Sepang peat terrain in Malaysia, *Journal of Terramechanics*, 41 (1) (2004) 25-40.
- [11] B. J. Jamaluddin, Sarawak: Peat agricultural use. Malaysian Agriculture Research and Development Institute (MARDI), pp. 1-12, 2002.
- [12] H.Singh, H.M. Bahia, B.B.K. Huat, Varying perspective on peat, it's occurrence in Sarawak and some geotechnical properties, *Proceedings of Conference on Recent Advances in Soft Soil Engineering and Technology, Malaysia*, 2-4 July, 2003.
- [13] A. Rahman, A.K.M. Mohiuddin, A. Hossain, A. F. Ismail, A. Yahya, Integrated mechanics of hybrid electrical air-cushion tracked vehicle for swamp peat, *Int. J. Heavy Vehicle Systems*, x (x) (2009) xxx-xxx, *Inderscience (In Press)*.
- [14] A. Hossain, R. Ataur, A.K.M. Mohiuddin, A.K.M.P. Iqbal, and M. Arifin, Modeling of the Developed Flexible Skirt Air-Cushion Track Vehicle Model, 4th BSME-ASME International Conference on Thermal Engineering, 27-29 December, 2008, Dhaka, Bangladesh.
- [15] R. Ataur, A.K.M. Mohiuddin, and A. Hossain, Effectiveness of the Developed Instrumentation System on the Vehicle Tractive Performance Measurement, *International Journal of Mechanical and Materials Engineering (IJMME)*, 2 (2) (2007) 118-124.
- [16] L. Zhe, Y. Fan, Load distribution control system design for a semi-track air-cushion vehicle, *Journal of Terramechanics*, 44 (4) (2007) 319-325.
- [17] J.Y. Wong, Performance of the air-cushion-surface-contacting hybrid vehicle for overland operation, *Proceedings of the IMech E*, 186 (50/72) (1972) 613-624.
- [18] A. Hossain, R. Ataur, A.K.M. Mohiuddin, and Y. Aminanda, Modeling and Simulation on Load Distribution of Air-Cushion Track Vehicle, 6th International Conference and 13th Annual Paper Meet of Mechanical Engineering Division, The Institution of Engineers, Bangladesh (IEB), 30-31 December, 2009, Bangladesh.
- [19] Hossain Altab, R. Ataur, A.K.M. Mohiuddin, and Y. Aminanda, Power Consumption Prediction for an Intelligent Air-Cushion Track Vehicle: Fuzzy Logic Technique, *Journal of Energy and Power Engineering (JEPE)*, x (x) (2010) xxx-xxx (In Press).
- [20] A. Hossain, R. Ataur, and A.K.M Mohiuddin, Intelligent Air-Cushion System of Swamp Peat Vehicle Control: Fuzzy Logic Technique, 8th International Conference on Mechanical Engineering, ICME 2009, 26-28 December, 2009, Bangladesh.