

Cultural Identity - A (Re)construction?

Joanne Muscat

Abstract—The study explored the question of who am I? As a (re)construction of cultural identity by delving into globalization, communication, and social change in Malta during a historical moment when Malta became a European Union Member State. Three objectives guided this qualitative study. Firstly the study reviewed European Union (EU) policies that regulate broadcasting and their implementation in Member States, whilst meeting the challenges of globalization and new media technology. Secondly the research investigated the changes of the media landscape via organizational structures, programs and television (TV) content. Finally the study explored the impact of these transformations taking place in the way Maltese live as they (re)construct their cultural identity. Despite the choices available to the Maltese audience, old local traditions and new foreign customs coexist as informants continue to (re)construct their cultural identity and define who they are.

Keywords—Cultural Identity, Globalization, Transnational Media.

I. INTRODUCTION

GLOBALISATION and the revolution in communication technology bring people closer together, but cause fears about the possible loss of cultural identity. How true is this? Transformations continue to penetrate today's society leading to the restructuring of information systems, increase of broadcasting channels, and introduction of cable, satellite, and digital networks across national and international borders. They have enabled access to a wide range of material previously undreamt of as distance ceases to be an obstacle in this borderless world. The question 'who am I?' thus becomes more significant to address especially in a small island Malta a European Union (EU) Member State.

II. LITERATURE REVIEW

A. Globalization

Technology has revolutionized access to information and as researcher [1] believes older systems of one-way cultural distribution are in a state of metamorphosis. Globalization [2] has been defined as the overall process whereby location of production transmission and reception of media content ceases to be geographically fixed. The dynamics of globalization are nowadays shaping a new media order. Nation states struggle to maintain control over the arrival of international communications as national borders cease to exist. Ironically, the same technology that gave rise to global TV may actually generate an unprecedented growth in local broadcasting.

Joanne Muscat is with the Malta Government at the Operations and Programme Implementation Directorate, Malta (e-mail: joannemuscazz@yahoo.com).

Many cultural consequences and changes are predicted to follow as a result of globalization including delocalizing and undermining local cultures. The present study is placed within such a context to trace changes occurring in Malta. This view is considered for the present study where local programs have emerged through the localization of foreign genre and continue to attract Maltese audience as local broadcasters find innovative roles to play.

B. Transnational Media

Transnational cultural productions are shifting towards commercializing local cultural content globally. Foreign influences penetrate Maltese households through the latest technology. This however, does not mean that foreign TV content is changing local content since the concept of heritage preservation has also taken on a new meaning to promote cultural diversity. Transnational media as referred to in this study relate to foreign programs received and transmitted according to Sepstrup model: via the national/local television channels; the foreign channels directly received via spill over; or other foreign channels directly received locally through cable or satellite reception. These flows are studied through changes in Malta media landscape.

The various forms of technological developments that overlap national frontiers have started to encourage nation states to expose their own cultures in view of foreign broadcasting influx. Media flows became increasingly transnational in character, adjusting to and influencing cross-border movements via media programs. The emerging order is complex, functioning across different cultural spaces at different levels local or global. It is diverse, juxtaposing cultures and creating new cultural experiences and encounters [3]. How are these affecting the regions, Europe, and Malta?

C. Cultural Identity

The effects of globalization, transnational media, media consumption and cultural identity reveal how technologies changed what has been our reality by shifting form information to a knowledge-based society. Cultural identity [4] relies heavily on the individuals' experience of their culture. Through this point of view, culture is always changing. It is not static. "Far from being eternally fixed in some essentialised past, they are subject to the continuous 'play' of history, culture and power."

Cultural identity refers to the constitution and cultivation of a reality on the basis of particular values, a reality in which the value system and the social system are completely interwoven and imbued with the activity of each other. Hall emphasize that everywhere, cultural identities are emerging which are not fixed, but poised, in transition, between different positions;

which draw on different cultural traditions at the same time; and which are the product of those complicated crossovers and cultural mixes that are increasingly common in a globalized world.

Concerns relating to transnational media, media landscape, and cultural identity, take place as the world moves towards globalization. Changes are also occurring in Malta, as a result of media pluralism (transnational media), EU membership and globalization. Reference [5] highlights that the challenge ahead lies into making of the media an important element in cultural formation

III. THEORY

The theoretical framework guiding the research covers both the transnational model [6] and audience reception theory. Both theory and model were selected as they contribute to the theme in question in understanding the challenges provided due to globalization and transnational television and their effects on nation states and their citizens. The transnational model was used notwithstanding its problems when applied to small countries like Malta. Reception analysis was also applied, taking into consideration its limitations.

The transnational model is relevant to the study as each of the three flows help in the process of tracing transformation in policies and changes in media landscape through content analysis. Furthermore, the effects of these three distinct flows are of utmost importance as they only occur when the content is not only transmitted but also received and responded to by the audience in other countries. If this happens the process of internationalisation affecting the society (cultural spheres) would be possible. It is a long way from the transmission of foreign produced TV content to any predictable foreign influence achieved. There are many obstacles of language barrier, cultural differences and diverse political ideologies. Therefore it is difficult to assume that results are causes of certain actions rather than others.

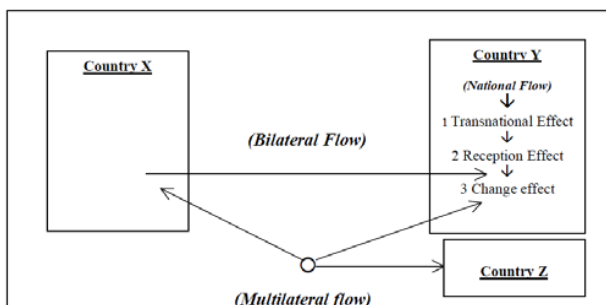

Fig. 1 Internationalization of TV model: three types of flow [7]

The present study assesses audience interpretation of content imparted through reception analysis that provides a more comprehensive understanding of the relationship between two particular groups and TV viewing. In this study, reception theory provides a framework to learn, when and why two groups turn to media and what they watch. A look at

these patterns may reveal how through the transitional and local media systems these groups (re)construct cultural identity.

IV. METHODOLOGY

A qualitative approach was used to uncover the meanings, which small groups generate focusing on the audience's situatedness within a particular socio-historical context. The qualitative approach used to conduct the study is based on four different techniques for triangulation purposes. The study conducted through the social constructionism framework, was divided into four stages using four different qualitative techniques: documentation analysis, content analysis, interviews and focus groups. The combination of documentation and content analysis, interviews and focus groups was deemed appropriate as each technique complement the other tools used.

Interviews and focus groups were audio record and transcribed to provide a complete record of the data collected. Raw data was organized by themes to facilitate analysis. Analysis aimed to look for trends and patterns that reappear within single groups or among various focus groups or interviewees. Data was divided into four main sections: policies, structures, TV content and audience discussions though through each technique other sub-themes emerged.

A. Documentation Analysis

Documentation analysis was applied to address the first objective by reviewing the media policies that structure the Maltese media landscape highlighting cultural identity issues therein. This technique helped to get a comprehensive and historical overview of how things function and are controlled. Documents analyzed included: Commitment to Pluralism white paper; broadcasting act; Malta communication authority act; laws and regulations of Malta; *Acquis Communautaire* (EU Law); European Convention on Transfrontier Television; European Community Directive on satellite services; and other official speeches. Each document was screened in relation to the broadcasting and its reflection on cultural identity.

B. Content Analysis

Content analysis was used to address the second objective relating to TV programming and TV content issues. The idea was to track changes highlighting: language; genre; origin of programs; content; time-slot and duration of program. The 2nd quarterly TV schedules covering April to June of 2003, 2004 and 2005 respectively were selected for the four TV station (TVM, Net, Super One and Smash TV). The period covers from pre-accession 2003, 2004 EU membership and 2005 a year after. The fieldwork was conducted in 2006. Furthermore only the weekdays were selected to eliminate possible special weekend programs that may vary results. The period was specifically selected to avoid as much as possible public and religious feasts, thus a normal period for broadcasting.

C. Interviews

Interviews were used to address the first and second objectives regarding policies and the media landscape via media structures and program content. Interviewees comprised of media owners and those in charge of policymaking issues to have a full spectrum of the situation pertaining within Malta. Thus the combination of interviews, documentation analysis and content analysis were conducted to complement each other in terms of findings and to sustain the theme of study. A total of eight interviews were conducted with leading personnel from: TVM (Public Broadcasting); Net TV (Political Party); Super One Television (Political Party); Smash TV (Commercial TV Station); Melita Cable Plc (Cable Provider); Broadcasting Authority; Malta Communication Authority; and Malta-EU Information Centre.

D. Focus Groups

Focus groups were applied to address the third objective that is the perception of cultural identity as a result of globalization, changes in policies, media landscape and EU membership. Eleven focus groups of 4 to 6 informants each for ease of practicality, manageability and control were organized. A total of fifty-two informants were selected from different tiers between the age of 25-34 and 45-54 years respectively covering the whole of Malta. The middle-class informants were then selected based on age; socioeconomic status; locality and education. Discussions held used a thematic interview guide and a bio-data form for each informant. The latter form was used as an introduction.

V. RESULTS

A. Main Findings

Fundamental changes worldwide underline historical specificity of the findings presented which transformed the media landscape ever since. The findings reveal a strong connection between history and tradition, combined with modernity. In this scenario people easily keep strong hold of the past whilst combine it with the new and modern. Small countries do things in different ways, behave differently and perceive TV content in unique ways. They mix local and international components to form a localized TV content. They regard foreign imports as mixed blessings since both advantages and disadvantages exist for the citizens themselves and for the society at large. In recent years, local TV programs in Malta increased as did their popularity among the public. Local productions may be promoting local culture broadcast in Maltese language but are often modeled on foreign TV shows hence cross-fertilization of culture is on-going in an age of advanced technology. Thus it should be perceived as a dynamic process of cultural evolution.

B. Media Landscape – Documentation & Interviews

Television without frontier and its revision through the audiovisual media service directives seek to promote endogenous (local) productions of TV to safeguard cultural

identity and heritage. Regulations were ratified into Malta legislation and enforced even further by setting up quotas for local television programs. Restructuring of local TV stations was inevitable to embrace latest technology and online media as a result of globalization and new social trends.

C. Media Programs – TV Content

Content changed as new foreign content and genre were studied and introduced locally. Localized content became available and popular with informants. Reinforcement of quotas to reach 50 per cent majority of productions to be made in Europe was maintained to nurture cultural and linguistic diversity within the country. Even the level of quotas exceeded 95 per cent local productions in Maltese Language.

D. TV Consumption – Focus Groups

Despite choices informants remain attached to local news and local stations mainly National TV. They are selective in what they watch and watch critically making them who they are. The informants accept and adopt critically what applies to them only. They are loyal to their culture, norms and values. The informants preserve their own cultural identity as best they can whilst they absorb what is relevant to them from outside their territory through television. Maltese cultural identity have been (re)constructed and solidified even further through social structures and TV consumption patterns of the middle-class Maltese who were the target group for the study.

VI. CONCLUSION

Europe will not make headway in building its unity without the backing of television, today's prime vehicle of culture, and neither will Malta. Cable, satellite and digital technology have been a determining factor in the way legal measures have evolved, as technological developments continue to undermine national control over what Maltese citizens watch. Legal provisions have to contend with the fact that informants prefer domestic productions restricted mainly to news, even in polyglot countries such as Malta.

As globalization, technology and EU membership opened up borders, changes in TV policies and media landscape occurred leading to the (re)construction of cultural identity. The Maltese (local) TV News remains the most favored by all middle-class informants, as it is their immediate reality. Foreign content however alienates them through virtual reality. In this sense cultural identity becomes a mixture of elements that are not homogeneous with a mixture of global and local - a hybrid cultural identity- a (re)construction.

The study reveals that middle-class Maltese feel proud as individuals, proud of their cultural identity, which makes them unique. The study concludes that an analytical approach based on micro-level adaptation remains relevant as transformations represent continuity between old and new. The informants continue to preserve their traditions, whilst left dancing to the tune of authorities, media producers and advertisers as they (re)construct their cultural identity thus defining who they are through time.

REFERENCES

- [1] H. Schiller, Not yet the post-imperialist era. *Critical Studies in Mass Communication* vol. 8, 1991, pp13-28.
- [2] D. McQuail, *McQuail's Mass Communication Theory*. 5th edition. London: Sage Publications, 2005.
- [3] D. Morley, & K. Robin, *Spaces of Identity, Global Media, Electronic Landscapes and Cultural Boundaries*. London: Routledge, 1995.
- [4] S. Hall, The question of cultural identity. In. S. Hall, D. Held and T. McGrew (eds.), pp. 274–316. *Modernity and its Futures*. Cambridge: Polity Press, 1992b.
- [5] J. Borg, A. Hillman, & M.A. Lauri, *Exploring the Maltese Media Landscape*. Malta: Allied Publications, 2009.
- [6] P. Sepstrup, Research into international TV Flows. *European Journal of Communication* vol 4, 1989, pp. 393-408.
- [7] D. McQuail, & S. Windhal, *Communications Models for the Study of Mass Communications*. London: Longmans, 1993.