

Application of Load Transfer Technique for Distribution Power Flow Analysis

Udomsak Thongkrajay, Padej Pao-La-Or, and Thanatchai Kulworawanichpong

Abstract—Installation of power compensation equipment in some cases places additional buses into the system. Therefore, a total number of power flow equations and voltage unknowns increase due to additional locations of installed devices. In this circumstance, power flow calculation is more complicated. It may result in a computational convergence problem. This paper presents a power flow calculation by using Newton-Raphson iterative method together with the proposed load transfer technique. This concept is to eliminate additional buses by transferring installed loads at the new buses to existing two adjacent buses. Thus, the total number of power flow equations is not changed. The overall computational speed is expectedly shorter than that of solving the problem without applying the load transfer technique. A 15-bus test system is employed for test to evaluate the effectiveness of the proposed load transfer technique. As a result, the total number of iteration required and execution time is significantly reduced.

Keywords—Load transfer technique, Newton-Raphson power flow, ill-condition.

I. INTRODUCTION

THE main function of an electric power transmission system is to deliver electric energy to its loads sufficiently, efficiently and economically. The steady-state performances of an interconnected power system during normal operation can be analyzed based on nonlinear nodal analysis to form power flow equations and must be solved by some efficient iterative methods [1-2]. Power flow analysis is commonly used as a part of power system operation and planning. Since AC power flow solution techniques were first developed over half a century ago, there exist two widely-used numerical methods, the Gauss-Seidel: GS and the Newton-Raphson: NR, to solve this problem. As broadly known, the NR method has been successfully developed and accepted as the most powerful algorithm in power flow analysis of electric power transmission systems. Increasing a total bus number results in slow computational speed of the calculation. In addition, in some power network structure, e.g. a bottle-neck power system [3-4], it does not converge to a solution due to an ill-condition problem [5].

Manuscript received March 31, 2008. This work was supported in part by the National Research Council of Thailand (Research Grant: SUT7-711-51-12-45) and Suranaree University of Technology, Thailand.

U. Thongkrajay, P. Pao-La-Or and T. Kulworawanichpong are with the School of Electrical Engineering, Suranaree University of Technology, Nakhon Ratchasima Thailand (phone: +6644-224400; fax: +6644-224601; e-mail: thanatchai@gmail.com).

In this paper, the power flow calculation is focused on the NR method. The proposed load transfer technique is presented in section II. A brief review of the NR method and an integration of the load transfer technique are described in section III. Section IV shows test cases and simulation results. They are challenged with ill-condition problems by varying an installed location of a capacitor bank started from the mid-point position of a selected feeder to the position close to one end of the feeder. The test case used herein is a 15-bus test system [7].

II. LOAD TRANSFER TECHNIQUE

To date, electric power systems have become more complex. Installation of power compensation equipment in some cases places additional buses into the system. Therefore, a total number of power flow equations and voltage unknowns increase due to additional locations of installed devices. This paper presents a power flow calculation by using Newton-Raphson iterative method together with the proposed load transfer technique. This concept is to eliminate additional buses by transferring installed loads at the new buses to existing two adjacent buses. Thus, the total number of power flow equations is not changed. The overall computational speed is expectedly shorter than that of solving the problem without applying the load transfer technique.

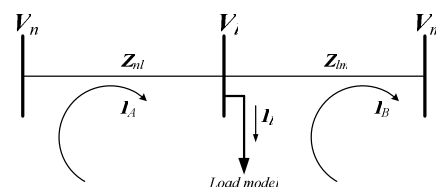

Fig. 1 Load installed at new bus l

From Fig. 1, the load installed at bus l can be analyzed using Kirchhoff's current law (KCL) as follows.

$$\text{Loop } I_1 : V_n - V_l = Z_{nl}I_A \quad (1)$$

$$\text{Loop } I_2 : V_l - V_m = Z_{lm}I_B \quad (2)$$

$$(1) + (2) : V_n - V_m = Z_{nl}I_A + Z_{lm}I_B \quad (3)$$

..., where $I_A = I_l + I_B$ and $I_B = I_A - I_l$

Eliminate I_B in (3), therefore

$$\begin{aligned} V_n - V_m &= Z_{nl}I_A + Z_{lm}(I_A - I_l) \\ &= (Z_{nl} + Z_{lm})I_A - Z_{lm}I_l \end{aligned}$$

Thus,

$$I_A = \left(\frac{Z_{lm}}{Z_{nl} + Z_{lm}} \right) I_l + \frac{(V_n - V_m)}{Z_{nl} + Z_{lm}} \quad (4)$$

Repeat the process to eliminate I_A in (3)

$$\begin{aligned} V_n - V_m &= Z_{nl}(I_B + I_l) + Z_{lm}I_B \\ &= (Z_{nl} + Z_{lm})I_B + Z_{nl}I_l \end{aligned}$$

That is,

$$I_A = - \left(\frac{Z_{nl}}{Z_{nl} + Z_{lm}} \right) I_l + \frac{(V_n - V_m)}{Z_{nl} + Z_{lm}} \quad (5)$$

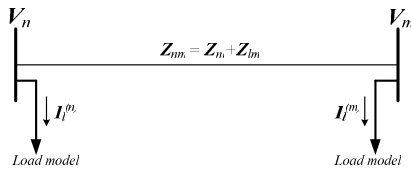

Fig. 2 Transfer load of bus l at two adjacent buses

The circuit of Fig. 1 is equivalent to that of Fig. 2. $I_l^{(n)}$ and $I_l^{(m)}$ can be expressed as follows.

$$I_l^{(n)} = \left(\frac{Z_{lm}}{Z_{nm}} \right) I_l \quad (6)$$

$$I_l^{(m)} = \left(\frac{Z_{nl}}{Z_{nm}} \right) I_l \quad (7)$$

In electrical power system analysis, loads are typically defined in form of electric power rather than current. I_l , the load current, can be rewritten in form of complex power as $(S_l/V_l)^*$. By substituting this expression into (6) and (7), the transferred load of bus l at its two adjacent buses is described separately as in (8) and (9).

$$I_l^{(n)} = \left(\frac{Z_{lm}}{Z_{nm}} \right) \left(\frac{S_l}{V_l} \right)^* \quad (8)$$

$$I_l^{(m)} = \left(\frac{Z_{nl}}{Z_{nm}} \right) \left(\frac{S_l}{V_l} \right)^* \quad (9)$$

With the load transfer technique, bus l is eliminated in order to simplify the overall calculation. After obtaining remained

bus voltage solutions, voltage at bus l is finally computed by using (10).

$$V_l = \left(\frac{Z_{lm}}{Z_{nm}} \right) V_n + \left(\frac{Z_{nl}}{Z_{nm}} \right) V_m + \left(\frac{Z_{nl}Z_{lm}}{Z_{nm}} \right) \left(\frac{S_l}{V_l} \right)^* \quad (10)$$

III. NEWTON-RAPHSON POWER FLOW METHOD

Given that an N -bus power system, which one bus is treated as a slack bus of constant voltage magnitude and zero phase angle, is shown in Fig. 3.

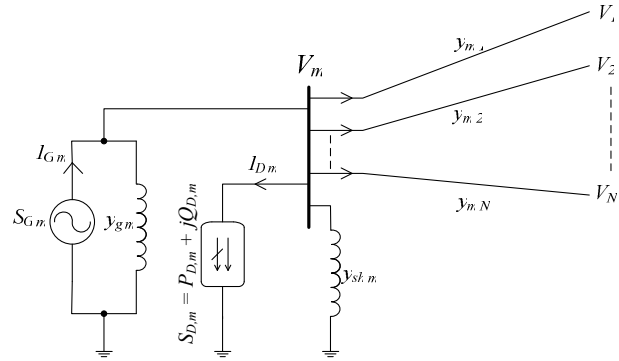

Fig. 3 Presentation of bus m

According to the NR method, the complex power of bus m in polar form as shown in (11). Also, this equation can be decomposed into real and reactive power equation as in (12) and (13).

$$\begin{aligned} (S_{sch,m})^* &= P_{sch,m} - jQ_{sch,m} \\ &= \sum_{i=1}^N |V_m V_i Y_{mi}| \angle (\theta_{mi} - \delta_m + \delta_i) \end{aligned} \quad (11)$$

$$P_{cal,m} = \sum_{i=1}^N |Y_{mi} V_m V_i| \cos(\theta_{mi} - \delta_m + \delta_i) \quad (12)$$

$$Q_{cal,m} = - \sum_{i=1}^N |Y_{mi} V_m V_i| \sin(\theta_{mi} - \delta_m + \delta_i) \quad (13)$$

Where,

$$S_{sch,m} = S_{gen,m} - S_{d,m}$$

$$P_{sch,m} = P_{gen,m} - P_{d,m}$$

$$Q_{sch,m} = Q_{gen,m} - Q_{d,m}$$

The proposed power flow method, given that S_T is a complex power transferred from additional bus l to bus n and bus m . The complex power transferred to bus n and bus m as follows.

$$S_{T,n} = V_n (I_l^{(n)})^* = \left(\frac{Z_{lm}}{Z_{nm}} \right) \left(\frac{V_n}{V_l} \right) S_l \quad (14)$$

$$S_{T,m} = V_m (I_i^{(m)})^* = \begin{pmatrix} Z_{lm} \\ Z_{nm} \end{pmatrix}^* \begin{pmatrix} V_m \\ V_l \end{pmatrix} S_i \quad (15)$$

$$\begin{bmatrix} \delta \\ |V| \end{bmatrix}^{(h+1)} = \begin{bmatrix} \delta \\ |V| \end{bmatrix}^{(h)} + \begin{bmatrix} J_1 & J_2 \\ J_3 & J_4 \end{bmatrix}^{-1} \begin{bmatrix} \Delta P \\ \Delta Q \end{bmatrix}^{(h)} \quad (18)$$

Where,

$$S_{T,n} = P_{T,n} + jQ_{T,n}$$

$$S_{T,m} = P_{T,m} + jQ_{T,m}$$

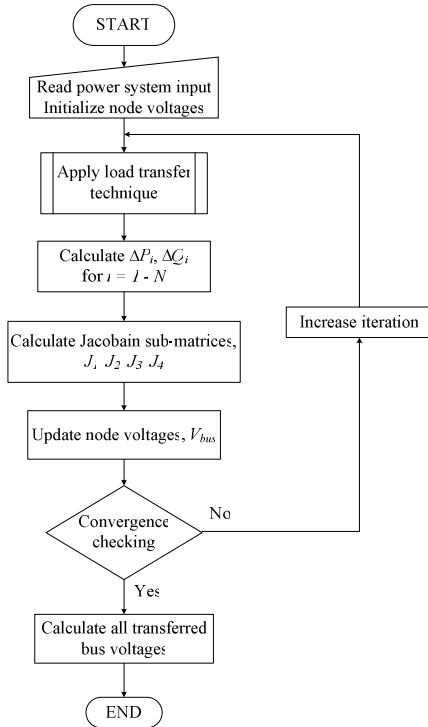

Fig. 4 Flow diagram for the proposed Newton-Raphson power flow calculation

There exist two choices for adding $S_{T,m}$ into a set of power flow equations, with $S_{cal,m}$ or $S_{sch,m}$. One choice can lead to very obvious difference in analysis. In this paper, to avoid tediously numerical computation of Jacobian matrices, the second choice is selected. Therefore, power mismatch equations must be rewritten as summarized in (16) – (17). In this case, Jacobian sub-matrices remain unchanged.

$$\Delta P_m = P_{sch,m} - P_{cal,m} \quad (16)$$

$$\Delta Q_m = Q_{sch,m} - Q_{cal,m} \quad (17)$$

Where,

$$P_{sch,m} = P_{gen,m} - P_{d,m} - P_{T,m}$$

$$Q_{sch,m} = Q_{gen,m} - Q_{d,m} - Q_{T,m}$$

With this computation, voltage magnitudes and phases can be updated iteratively by using the follow equation where h indicates a counter of iteration.

In addition, a power flow solution based on the load transfer technique as shown in the flow diagram of Fig. 4.

IV. SIMULATION RESULTS

To evaluate the effectiveness of the proposed power flow calculation, the 15-bus test system with 1226.4 kW and 1251.2 kVar as show in Fig. 5 is employed to test under MATLAB™ programming environment. The test was carried out by using an Intel core 2 duo 1.6 GHZ, 512 MB DDR-2 RAM computer.

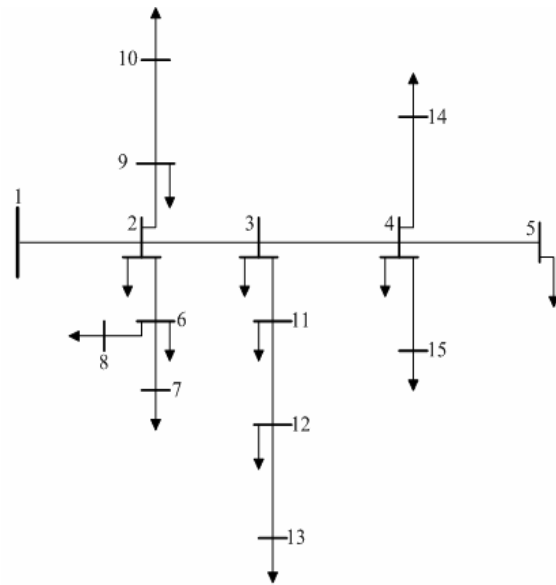

Fig. 5 15-bus test system [9]

Five installed load locations are assumed. All locations of an installed loads are set at the mid of the line. Details of installed loads are given below.

Load 1: 50 + j60 kVA in between bus 9 and bus 10

Load 2: 70 + j80 kVA in between bus 11 and bus 12

Load 3: 50 + j60 kVA in between bus 12 and bus 13

Load 4: 70 + j80 kVA in between bus 4 and bus 14

Load 5: 90 + j100 kVA in between bus 4 and bus 15

To perform all the tests, all initial bus voltages are assumed to be 1.00 p.u. and to terminate the iterative process, maximum voltage error is set as 1.0×10^{-4} p.u. for both power flow methods. The results obtained are presented in Table I and Table II. Table I gives the comparison among the convergence and calculation time of the standard NR method and the NR with using the proposed load transfer technique. Whilst, Table II shows magnitudes and phase angles of the bus voltages obtained by using each approach.

TABLE I
COMPARISON OF CONVERGENCES AND CALCULATION TIMES

Number of new loads	Iteration used		Execution time	
	SNR	TNR	SNR	TNR
1 (Load 1 only)	5	5	100%	94%
2 (Loads 1 – 2)	5	5	100%	85%
3 (Loads 1 – 3)	5	5	100%	80%
4 (Loads 1 – 4)	5	5	100%	77%
5 (Loads 1 – 5)	5	5	100%	69%

SNR = The standard NR method

TNR = The NR method with the load transfer technique

TABLE II
POWER FLOW SOLUTIONS OF EACH METHOD

Node no.	Magnitude (p.u.)		Phase (degree)	
	SNR	TNR	SNR	TNR
1	1.0000	1.0000	0.0000	0.0000
2	0.9624	0.9624	0.0691	0.0691
3	0.9413	0.9413	0.1141	0.1141
4	0.9329	0.9329	0.1321	0.1321
5	0.9319	0.9319	0.1447	0.1447
6	0.9492	0.9492	0.2295	0.2295
7	0.9470	0.9470	0.2572	0.2572
8	0.9479	0.9479	0.2454	0.2454
9	0.9575	0.9575	0.1371	0.1371
10	0.9557	0.9557	0.1618	0.1618
11	0.9310	0.9310	0.2566	0.2566
12	0.9234	0.9234	0.3674	0.3674
13	0.9213	0.9213	0.3992	0.3992
14	0.9293	0.9293	0.1815	0.1815
15	0.9296	0.9296	0.1766	0.1766
16	0.9563	0.9563	0.1552	0.1552
17	0.9265	0.9265	0.3228	0.3228
18	0.9219	0.9219	0.3906	0.3906
19	0.9305	0.9305	0.1668	0.1668
20	0.9308	0.9308	0.1607	0.1607

As can be seen, to install new loads into an existing power system can cause slower calculation time due to the increment of Jacobian matrix's size. The load transfer technique is one among the efficient schemes to handle this computation.

V. CONCLUSION

This paper presents the proposed load transfer technique to solve slow convergence of power flow calculation due to additional load installation. Installation of power compensation equipment in some cases places additional buses into the system. Therefore, a total number of power flow equations and voltage unknowns increase due to additional locations of installed devices. The proposed technique is to eliminate additional buses by transferring installed loads at the new buses to existing two adjacent buses. Thus, the total number of power flow equations is not changed. The overall computational speed is numerically shorter than that of solving the problem without applying the load transfer technique. A 15-bus test system is employed for test to verify the effectiveness of the proposed load transfer technique. As a result, the total number of iteration required and execution time is significantly reduced.

REFERENCES

- [1] J.J.Grainger and W.D. Stevenson, *Power system analysis*, McGraw-Hill, 1994.
- [2] S. Hadi, *Power system analysis*, McGraw-Hill, 2004.
- [3] K.R.C. Mamandur, G.J. Berg, "Automatic adjustment of generator voltages in Newton-Raphson method of power flow solutions," *IEEE Trans. Power Apparatus and Systems*, vol. pas-101, no. 6, pp. 1400-1409, 1982.
- [4] G. Huang and W. Ongsakul, "Managing the bottlenecks in parallel Gauss-Seidel type algorithms for power flow analysis", *IEEE Power Industry and Computer Application*, May 1993, 4-7.
- [5] P.R. Bijwe and S.M. Kelapure, "Nondivergent Fast Power Flow Methods", *IEEE Trans. on Power Systems*, Vol. 18, No. 2, May 2003, 633-638.
- [6] M.E. El-Hawary and O.K. Wellon, "The alpha-modified quasi-second order Newton-Raphson method for load flow solutions in rectangular form," *IEEE Trans. Power Apparatus and Systems*, vol. pas-101, no. 6, pp. 854-866, 1982.
- [7] B. Stott, "Decoupled Newton load flow," *IEEE Trans. Power Apparatus and Systems*, vol. pas-91, no. 5, pp. 1955-1959, 1972.
- [8] F.F. W., "Theoretical study of the convergence of the fast decoupled load flow," *IEEE Trans. Power Apparatus and Systems*, vol. pas-96, no. 1, pp. 268-275, 1977.
- [9] S.C. Chapra, *Numerical methods for engineers: with programming and software applications*, McGraw-Hill, 1998.
- [10] D. Das, D.P. Kothari and A. Kalam, "Simple and efficient method for load flow solution of radial distribution networks", *Electrical Power & Energy Systems*, Vol. 17, pp. 335-346, 1995.