

Steady-State Performance of a New Model for UPFC Applied to Multi-Machines System with Nonlinear Load

S.Ali Al-Mawsawi

Abstract—In this paper, a new developed construction model of the UPFC is proposed. The construction of this model consists of one shunt compensation block and two series compensation blocks. In this case, the UPFC with the new construction model will be investigated when it is installed in multi-machine systems with non-linear load model. In addition, the steady-state performance of the new model operating as impedance compensation will be presented and compared with that obtained from the system without compensation.

Keywords—UPFC, PWM, Nonlinear load, Multi-Machines system

I. INTRODUCTION

THE rapid development of power electronics technology provides exciting opportunities to design new power system equipment for better utilization of existing systems. During the last decade, a number of control devices under the term "Flexible AC Transmission Systems (FACTS)" technology have been proposed and implemented [1-6]. FACTS devices can be effectively used for power flow control, loop-flow control, load sharing among parallel corridors, voltage regulation, enhancement of transient stability, and mitigation of system oscillations. In 1991, a unified power flow controller (UPFC) concept was proposed by Gyugyi [1]. It is a multi-functional FACTS controller with the primary function of power flow control plus possible secondary duties of voltage support, transient stability improvement and oscillation damping, etc. [1,2]. The installation of the UPFC in power systems has recently come under intensive investigation into its modeling and various control functions, including damping control for single-machine infinite-bus power systems. Many papers have been published related to modeling the UPFC into multi-machine power systems in steady-state mode of operation for studying power flow control [7-12]. However, most of the work done was using the original Gyugyi construction model of the UPFC (series compensation block (Converter 1) and shunt compensation block (Converter 2) as illustrated in Figure 1 [7-20].

S. Ali Al-Mawsawi is with University of Bahrain, P.O. Box 32038, Isa Town, Department of Electrical and Electronics Engineering (phone: +973-39899088; fax: +973-17680924; e-mail: salmosawi@eng.uob.bh).

In this paper, a new develop construction model of a UPFC is proposed. The construction of this model consists of one shunt compensation block and two series compensation blocks. A UPFC with the new construction model installed in multi-machine systems with non-linear load model will be investigated. In addition, the steady-state performance of the new model operating as impedance compensation will be presented and compared with that obtained from the system without compensation.

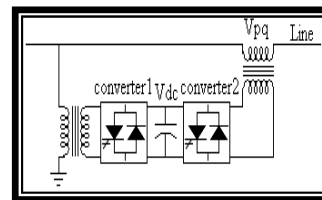

Fig. 1 A block diagram of a UPFC

II. MULTI-MACHINES SYSTEM WITH THE NEW UPFC AS IMPEDANCE COMPENSATION AND VOLTAGE REGULATOR

In this case, the UPFC has three converters that are all connected to the DC link as shown in Figure 2. Operation of the three converters is based on PWM method. The first converter is the shunt converter and its modulation index is selected to be 100%. The second converter (series injection) is installed between the Bus 1 and Bus 3. This converter is operated as an impedance compensator with an amplitude V_{pq1} and a phase angle of ($\rho = -\theta - 90$) degrees so that its output voltage is in quadrature with the line current I_1 . The magnitude of the output voltage of this converter can be controlled by varying its modulation index M_{pq1} from 10% to 100%. The third converter is installed at the line between Bus 1 and Bus 2. This converter is operated as a voltage regulator of amplitude of V_{pq2} and at an angle in phase with the terminal voltage at Bus 1 (angle of 0 degrees). The magnitude of the output voltage of this converter can be controlled by varying its modulation index M_{pq2} from 10% to 100%. Therefore, the advantage of this model is that it can install only one FACTS device which can control two lines in the transmission system rather than installing two different FACTS devices. The steady-state model of the multi machine systems with the new developed UPFC is shown in Figure 3.

If the system has a nonlinear load that depends on the terminal voltage V_3 , then the active and reactive power could be characterized as follows [22]:

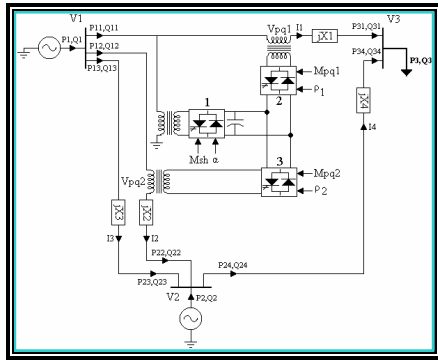

Fig. 2 Multi-machines system with the new developed UPFC

$$P_3 = P_0 \left(\frac{V_3}{V_{30}} \right)^a \tag{1}$$

$$Q_3 = Q_0 \left(\frac{V_3}{V_{30}} \right)^b \tag{2}$$

where, a and b are constant values and P_0 , Q_0 and V_{30} are equal to the initial values of P_3 , Q_3 and V_3 respectively.

In order to operate the UPFC as an impedance compensator, the voltage V_{pq} should be injected into the transmission line in quadrature with the transmission line current I_1 , and thus the angle of V_{pq} must be:

$$\rho = -\theta - 90^\circ \tag{3}$$

where θ is the angle of the current I_1 with respect to the reference voltage V_1 .

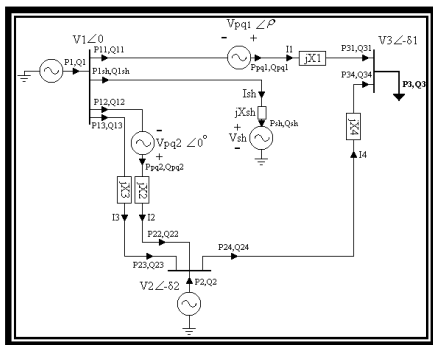

Fig. 3 The steady state model of the multi machine systems with new developed UPFC

From the complex powers of the system, all active and reactive powers can be calculated for the system as follows:

$$P_{11} = -\frac{V_1 V_{pq1}}{X_1} \cos(\theta) + \frac{V_1 V_3}{X_1} \sin(\delta_1) \tag{4}$$

$$Q_{11} = -\frac{V_1 V_{pq1}}{X_1} \sin(\theta) - \frac{V_1 V_3}{X_1} \cos(\delta_1) + \frac{V_1^2}{X_1} \tag{5}$$

$$P_{31} = \frac{V_1 V_3}{X_1} \sin(\delta_1) - \frac{V_3 V_{pq1}}{X_1} \cos(\theta - \delta_1) \tag{6}$$

$$Q_{31} = \frac{V_1 V_3}{X_1} \cos(\delta_1) - \frac{V_3 V_{pq1}}{X_1} \sin(\theta - \delta_1) - \frac{V_3^2}{X_1} \tag{7}$$

$$P_{pq1} = \frac{V_1 V_{pq1}}{X_1} \cos(\theta) - \frac{V_3 V_{pq1}}{X_1} \cos(\delta_1 - \theta) \tag{8}$$

$$Q_{pq1} = -\frac{V_1 V_{pq1}}{X_1} \sin(\theta) + \frac{V_{pq1}^2}{X_1} - \frac{V_3 V_{pq1}}{X_1} \sin(\delta_1 - \theta) \tag{9}$$

$$P_{12} = \frac{V_1 V_2}{X_2} \sin(\delta_2) \tag{10}$$

$$Q_{12} = \frac{V_1^2}{X_2} - \frac{V_1 V_{pq2}}{X_2} - \frac{V_1 V_2}{X_2} \cos(\delta_2) \tag{11}$$

$$P_{22} = \frac{V_1 V_2}{X_2} \sin(\delta_2) - \frac{V_2 V_{pq2}}{X_2} \sin(\delta_2) \tag{12}$$

$$Q_{22} = \frac{V_1 V_2}{X_2} \cos(\delta_2) - \frac{V_2 V_{pq2}}{X_2} \cos(\delta_2) - \frac{V_2^2}{X_2} \tag{13}$$

$$P_{pq2} = \frac{V_2 V_{pq2}}{X_2} \sin(\delta_2) \tag{14}$$

$$Q_{pq2} = \frac{V_1 V_{pq2}}{X_2} - \frac{V_{pq2}^2}{X_2} - \frac{V_2 V_{pq2}}{X_2} \cos(\delta_2) \tag{15}$$

All the other active and reactive powers in other lines can be found in a similar way.

Since the operation of the converters of the UPFC is based on PWM method, the relation between the magnitude of the voltages of V_{pq1} and V_{pq2} with the magnitude of voltage of V_{sh} as a function of the modulation index can be written as [21]:

$$|V_{pq1}| = K_1 \cdot M_{pq1} \cdot |V_{sh}| \tag{16}$$

$$|V_{pq2}| = K_2 \cdot M_{pq2} \cdot |V_{sh}| \tag{17}$$

where M_{pq1} and M_{pq2} is the modulation index of the converters (2) and (3) respectively and both can be varied from (10% to 100%). The voltage V_{sh} has an angle α with respect to the transmission line voltage V_1 . This angle will determine the

amount of power transfer needed from converter (1) to converters (2) and (3).

For the sake of simplicity, it is assumed that the active power consumed by this FACTS device is zero. Therefore,

$$P_{sh} - P_{pq1} - P_{pq2} = 0 \tag{18}$$

III. SIMULATION RESULTS

The system in Figure 3 has been modeled and simulated using Matlab. In this case, an active power (P_2) supplied to the grid by the synchronous machine (2) is selected to be 2.479 p.u. and the active power (P_1) is considered as variable power demanded by the load. The impedance of the reactance of the transmission lines are selected to be: $X_1=0.04$ p.u., $X_2=X_3=0.22$ p.u. and $X_4=0.047$ p.u. [23]. The constants a & b of the non-linear load given in Equation (1) and Equation (2) are considered to be 1.38 & 3.22 respectively [22]. The other parameters are $V_{30} = 1$ p.u., $P_0 = 6.381$ p.u., $Q_0 = 0.2458$ p.u., $V_1=1.018$ p.u., and $V_2=1.011$ p.u..

For the system shown in Figure 3, the steady state performance of UPFC was investigated for two different values of the modulation index. The flow of active and reactive powers in all the lines was also recorded. In this case, the modulation index of converter 3 (Mpq2) has very little affect on the power flow in all lines as shown in Figure 4. However, the most changes in active power flow come from changing the modulation index of converter 2 (Mpq1). Therefore, converter 3 has much less sensitivity than converter 2 on controlling the active power flow between Bus 1 and Bus 3. But we can see that converter 3 has much higher sensitivity effect on the reactive power flow on some transmission lines as shown in Figure 5.

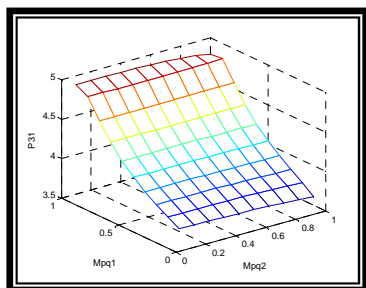

Fig. 4 The flow of active power (P_{31}) as modulation index of converters 2 and 3 are varying

In addition, Figure 6 and Figure 7 show the comparison of the active and reactive power flows in the lines before and after the compensation at 100% modulation index. These two figures show that both this Model can be used for controlling the flow of the active and reactive power in the transmission lines. However, both figures also show that the amount of compensation of active and reactive powers in the transmission lines using the new Model is reasonable. In addition, this Model can be used to control two transmission lines in the

same time and therefore the range of controlling the power flow in this case will be larger and more flexible.

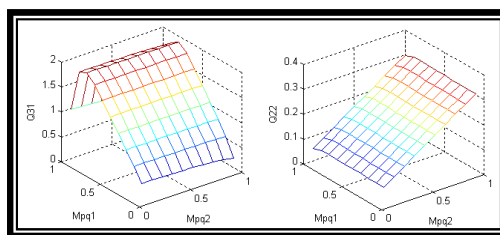

Fig. 5 The flow of reactive power (Q_{31} and Q_{22}) as modulation index of converters 2 and 3 are varying

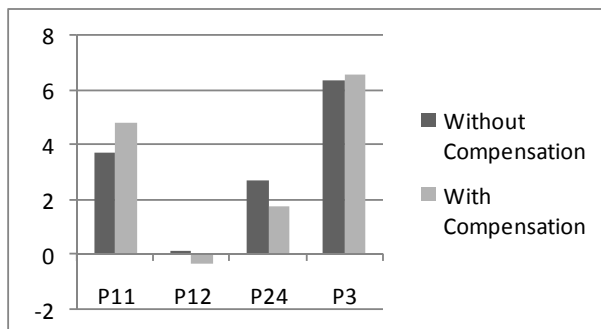

Fig. 6 The flow of active power in the transmission line without the compensation and with the compensation using Model (1) and (2)

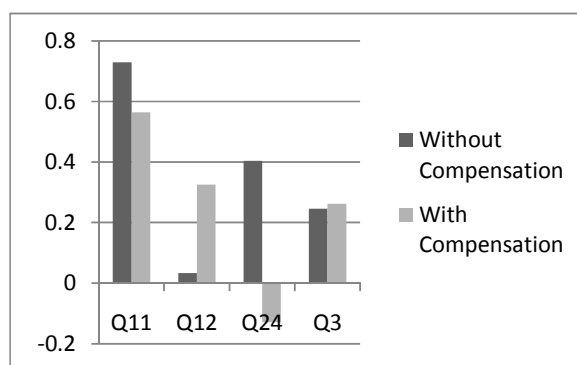

Fig. 7 The flow of reactive power in the transmission line without the compensation and with the compensation using Model (1) and (2)

IV. CONCLUSION

A new model of UPFC was proposed. The construction of this model consists of one shunt compensation block and two series compensation blocks. The UPFC with the new construction model was investigated when installed in multi-machine systems with non-linear load model. The steady-state performance of the new model operating as impedance compensation was presented and compared with that obtained from the system without compensation. The results found in this paper would be very useful in selecting the highest possible amount of compensation of active or reactive power flow in transmission lines.

APPENDIX (NOTATIONS)

- P_{nm} = Active power flow in the transmission line from point n to m.
 Q_{nm} = Reactive power flow in the transmission line from point n to m.
 V_n = Voltage at n point of the transmission line.
 V_{pq} = Injection voltage from the series compensation block of UPFC.
 I_n = Current in n transmission line.
 M_{pq} = Modulation of the series compensation block of UPFC.
 α = Angle of the controller of the shunt compensation block of UPFC.
 ρ = Angle of the controller of the series compensation block of UPFC.
 δ_n = Angle of V_n .
 θ = Angle of the transmission line current I_l .
 Appendixes, if needed, appear before the acknowledgment.

REFERENCES

- [1] L. Gyugyi, *A Unified power flow control concept for flexible ac transmission systems*, IEE Proceedings C, Iss. 4, No. 139, July 1992, pp. 323-331
- [2] N. G. Hingorani, *Flexible ac transmission*, IEEE spectrum, April 1993, pp. 40-45
- [3] C.R. Fuerte-Esquivel, E. Acha, "Unified power flow controller: a critical comparison of Newton-Raphson UPFC algorithms in power studies", IEE Proceeding-C Generation Transmission Distribution, Vol. 144, No. 5, 1997.
- [4] L. Gyugyi, "Solid- state control of electrical power in an AC transmission system", International symposium on electric energy converters in power systems. Invited paper T- IP – 4 - (Capri), Italy, 1989.
- [5] L. Gyugyi, C.D. Schauder, "The unified power flow controller: a new approach to power transmission control", IEEE, Transactions on Power systems, 1994.
- [6] H.F. Wang, "Damping function of unified power flow controller", IEE Proceeding of Generation, Transmission and Distribution, Vol. 146, No. 1, Pages 81-88, 1999.
- [7] H.F. Wang, F.J. Swift, "An unified model for the analysis of FACTS devices in damping power system oscillations Part II: multi-machine infinite-bus power systems", IEE Trans. Power Deliv., No. 2, pp. 941-946, 1998.
- [8] E.V. Larsen, J.J. Sanchez-Gasca, and J.H. Chow, "Concept for design of FACTS controlling to damp power swings", IEEE Trans. Power Syst. Vol. 10, No. 2, pp 948-956, 1995.
- [9] H.F. Wang, "Selection of robust installing locations and feedback signals of FACTS based stabilizers in multi-machine power systems", IEEE Trans. Power Syst., No. 2, pp. 569-574, 1999.
- [10] H.F. Wang, "Applications of modeling UPFC into multi-machine power systems", IEE Proc. Transm. Distrib. Vol. 146, No. 3, pp. 306312, May 1999.
- [11] H. Zhengyu, N. Yinxi, "Application of Unified power flow controller in interconnected power systems-modeling, interface, control strategy and case study", IEEE Trans. on Power Systems, Issue 2, Vol. 15, pp. 817-824, May 2000.
- [12] H.F. Wang, "Modeling multiple FACTS devices into multi-machine power systems and applications", International Journal of Electrical Power Systems, Vol. 25, No. 3, pp. 227-237, 2003.
- [13] S. Ali Al-Mawsawi, M.R. Qader, "Optimal location of a UPFC applied to non-linear load model", EPC&S: The International Journal for Electric Power Components and Systems, Volume 32, No. 1, January 2004, Pages 1-12.
- [14] S. Ali Al-Mawsawi, "Comparing and evaluating the voltage regulation of a UPFC and STATCOM", International journal of Electrical power and energy Systems, Volume 25, Issue 9, November 2003, Pages 735-740.
- [15] S. Ali Al-Mawsawi, M.R. Qader, K.L. Lo, "Evaluating the voltage regulation of a UPFC using PI and fuzzy logic controller", COMPEL: The International Journal for Computation and Mathematics in Electrical and Electronic Engineering, Volume 21 Issue 3, 2002. , Pages 409-424.
- [16] S. Ali Al-Mawsawi, M.R. Qader, "Evaluation of a PWM based UPFC as impedance compensation using fuzzy logic", The International Journal of Engineering Intelligent Systems. Vol. 9, No.1, pp. 11-17, March 2001.
- [17] S. Ali Al-Mawsawi, M.R. Qader, G.M. Ali, "Dynamic controllers design for STATCOM", Iranian Journal of Electrical and Computer Engineering, Vol. 3, No. 1, Winter-Spring 2004, Pages 16-22.
- [18] Ali Zanech, Ahmed Kazemi, Majid Hajalipour and Shahram Jadid, "Alyapunor Theory Based UPFC Controller for Power Flow Control", International Journal of Electrical Power and Energy Systems, Volume 31, Issues 7-8, September 2009, Pages 302-308.
- [19] R.K. Pandey and N.K. Singh, "UPFC Control Parameter Identification for Effective Power Oscillation Damping", International Journal of Electrical Power and Energy Systems, Volume 31, Issues 6, July 2009, Pages 269-276.
- [20] Ali T. Al-Awani, Y.L. Magid and M.N. Abido, "A Particle Swarm Based Approach of Power System Stability Enhancement with Unified Power Flow Controller", International Journal of Electrical Power and Energy Systems, Volume 29, Issues 3, 2007, Pages 251-259.
- [21] N. Mohan, T. M. Undeland, and W. P. Robbins, *Power Electronics: Converters applications and design*, John Wiley & sons, 1989.
- [22] W.W. Price et. Al. IEEE task forced on load representation for load dynamic performance, system Dynamic performance subcommittee, power system engineering committee, *Bibliography on load models for power flow and dynamic performance simulation*, IEEE Transactions on Power Systems, Vol. 10, No. 1, February 1995.
- [23] W.D. Stevenson, "Elements of power system analysis", Fourth Edition, McGraw-Hill, 1982, Pages 200-202.