

Wireless Communicated Smart Wind Sensor

Zdenek Bohuslavcek

Abstract—Development of microprocessor controlled sensor for measurement of wind speed and direction is the aim of this study. Electrical circuits and software were developed to the existing electromechanical part of the sensor TM-W2 becoming the properties of so-called smart sensor. The measured data about wind speed (sensitivity 0.01 m/s) and direction (0-360° by step 10°) are transmitted as 16-bit information. The connection between sensor and control unit is realized by radio communication (FM 433 MHz). Transition range is 220 m if used Quad type antenna. This concept provides substitution of actual cable systems by wireless ones.

Keywords—smart wind sensor, anemometer, wind speed, wireless communication

I. INTRODUCTION

THE comfort of “wireless” information transmission has been primarily asserting itself not only into wireless networks but it penetrating also into the industry standards and special power saving technologies, covering with their properties a wide area of usability of varied applications in a real environment [1], [2], [3]. Interesting power saving technologies for the RF communication are supporting products of various manufacturers (for example Aurel, Nordic, Nanotron etc.), involving a wide spectrum of products like radio-modems, transmitters, receivers or modules for a transparent substitution of the cable telecommunications. The paper is showing a solution of special application of the wireless data transfer, concretely on the smart sensor development for the measuring of wind velocity and direction. The solution is contributing with a number of functional and manipulation advantages, as well as the economical benefits.

II. PROBLEM FORMULATION

A. Survey of fundamental requirements on the developed sensor:

The new sensor shall have characteristics of digital both-way communication sensor powered independently from an own battery. The functional performance would class it with the category of smart sensors. Now, the additional requirements in brief:

- Designed on the base of an electromechanical sensor structure TM-W2 keeping the display resolution (detection?) and precision of measured data.

Z. Bohuslavcek is with the Czech University of Life Sciences Prague Faculty of Engineering, Department of Electrical Engineering and Automation Prague, Czech Republic, bohuslav.zd@seznam.cz, tel.: +4202 2438 3300

- The solution would facilitate an innovation of the METEOS measuring systems, enabling their use in the new measuring systems.
- The wireless communication would be performed at the minimum distance of 200m.
- Error-free transmission and data security transmission would be assured

B. Topics of the TM-W2 electromechanical sensor and of the METEOS measuring system.

The TM-W2 uses a rotating vane cross (cupwheel) as a wind speed sensor and for the wind direction, a sensor with rotary direction label is used. The sensor does not have an own powering and the simplified electro-optical sensors embedded in the sensor body are taking power from the service wiring. The output impulse



Fig. 1 Sensor TM-V2

signal of this sensor is carrying a collected information about wind speed and direction. The sensor generates 36 impulses per one anemometer shaft turn. The wind speed is derived from the frequency of impulses. The wind direction sensor is encoding (levelling) the impulses by such a way that in a frame of 36 impulses, the determined impulses with a bigger amplitude and the remnant ones with a lower amplitude are aligned in it. In proportion to the rate of higher amplitude impulses, the wind direction is interpreted in tens of angular azimuth degrees. This sensor is intended for the meteorological stations, airports and other application on the area of environmental measures, in research, industry agriculture, sand the like.

The METEO-5 System is intended for measuring and for 24 hours recording of wind speed and direction, obtained from four TM-V2 sensors. An exploitation of this system is met at the wind erosion effect research as well as at the efficiency checking of wind barriers. The appliance consists of a “mobile” central-exchange (20kg) equipped with an embedded MITE 386 computer, analog-to-digital converter board, stabilized AC adapter and 12V/35Ah accumulator with charging circuit. The TM-B2 sensors are to be connected to the central-exchange with four 600m three core cables of 600m total length. For the installation in terrain, 4 masts with 3m or 5m basic highth are designated. The data stored in the central-exchange are transferred by serial RS232 data

interface into an usual computer and analysed and evaluated here with the Win-METEO program.

B. Basic solution design concept of the HW and SW sensor parts.

A conceptual sensor block diagram is on the Fig.,2. The sensor basic parts are shaped by an electromechanical sensor TM-V2 (S1), micro-controller unit (MCU) and a radio frequency module which is described in [4]. The MCU of this sensor is providing own measurement and processing of the signal coming from the wind sensors and the information transmission to the central-exchange by means of the radio communication.

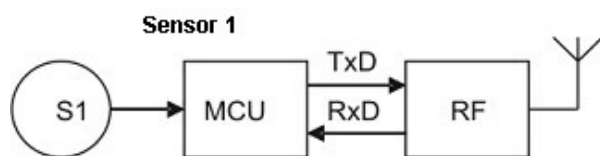

Fig. 2 Sensor conceptual structure

The own physical communication is provided with a RF module on the frequency of 433 or 868 MHz, connected to the MCU through the serial UART port. After have started, the MCU is making the RF module configuration setup and then the control signals coming on the radio channel would be expected only. The sensor is transmitting the measured data on a remote central-exchange request, it does not transmit anything by oneself because it is waiting on a control command only. However, the measurement is performed continually and the values of measured units are being actualized in the RAM MCU for all the time.

III. PROBLEM SOLUTION

A. Solution of processing and digitalization of the signal obtained from sensors by means of micro-controller.

For the sensor action control, an AVR, Atmega8L type, characterized by effective program code, high velocity of processing instructions and low price. The principle of processing of impulse signal from TM-V2 sensors is explained by the block diagram on the Fig. 3 in graphic format. For the measuring of period of impulses got from TM-V2, an internal hardware 16 bit counter/timer clock set in function of a simple frequency counter derived from the MCU oscillator is used. Between the oscillator and T1 counter, a pre-divider is possible to be plugged, and this pre-divider would generate frequency suitable for the T1 counter incrementation [3]. The conjugated signal from TMV-V2 carrying an information about wind speed and direction, is wired in parallel into two MCU inputs.

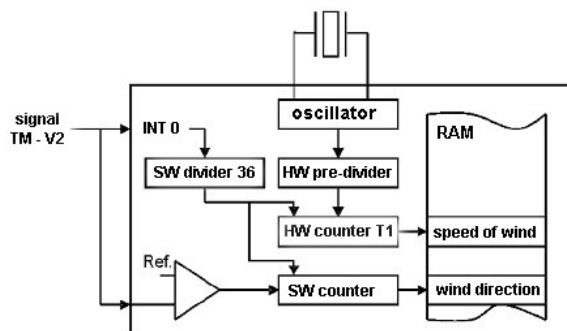

Fig. 3 A graphical interpretation of signal processing solution with the micro-controller unit (MCU)

The first input is an inverting one of internal analogue comparator, reflecting with cut off only on the impulses with a bigger amplitude. In operating interrupts from comparator, a software counter cumulatively counting these interrupts is pre-programmed. The second input is an INT0 interrupt, in its operation, all impulses coming from the sensors are processed. Here, a software pre-divider is pre-programmed, doing that 35 impulses have been ignored and just every 36th would cause the measured values transfer into the variables in RAMs followed by an instant reset of the T1 and SW counters. The T1 counter value would be translated to the variable of „wind direction“ representing the number of high amplitude pulses in 36 pulses in total and herewith interpreting immediately azimuth in tens of angular degrees. The VF value of „wind speed“ variable is given with:

$$VF = (f_{osc} * 36) / (K_{pr} * f_s) \quad (1)$$

where f_{osc} - MCU oscillator frequency

K_{pr} - pre-divider constant

f_s - frequency of wind sensor impulses

The oscillator frequency has been set first of all with regards on the required range of measurement of impulses (wind speed). The lower limit of the measuring range (the lower measurable wind speed) is given by overrun of the T1 16 bit counter/time clock T1, at this overrun, the maximum value of 65535 is transferred into RAM. The upper limit of the measuring range is given with the a required T1 counter resolution 1000 scale division to one anemometer turn at the maximum sensor frequency of impulses 14000 Hz. The MCU characteristics resulted with limiting factors, first of all the oscillator maximum frequency of 8 MHz and relatively little choice of the possible pre-divider constants taken from the array 1, 8, 64, 256 or 1024. The commensurable ness with the central switchboard oscillator frequency was another factor caused by easy reconstruction back without complicated and disprecisioning calculations. Lastly, a selection from frequency series of just produced X-tal resonator has been necessary. The frequency 4,9152MHz resulted from the mentioned requirement as a compromise. The pre-divider radio has been set on 64. A lower limit of frequency impulses

of sensors for the chosen frequency resulting at $VF_D = 65535$:

$$f_{SD} = (f_{osc} * 36) / (K_{pr} * VF_D) =$$

$$= (4\ 915\ 200 * 36) / (64 * 65\ 535) = 42,188\ \text{Hz} \quad (2)$$

it is 1,2 rotation per second at 36 impulses per rotation. Then the upper limit for $VF_H = 1000$ is:

$$f_{SH} = (f_{osc} * 36) / (K_{pr} * VF_H) =$$

$$= (4\ 915\ 200 * 36) / (64 * 1000) = 2359,8\ \text{Hz} \quad (3)$$

Both of that is complying with the required values.

B. Designed and by experimental way verified applications with a smart sensor.

The designed sensor has been practically verified in two measuring systems. The first application was a simple substitution of cable wiring of the TM-V2 sensor to the original METEOS-5 central-exchange, as it was required by the user of this system. The second application has been fully modernized system already with a central switchboard providing an on-line evaluation, graphical presentation etc., as it was described in [6].

With regard to attraction of the solution of a simply substitution of cables of the old METEOS system in the first application, it is in place to describe briefly a synchronised radio receipt solution of signals from 4 innovated TM-V2

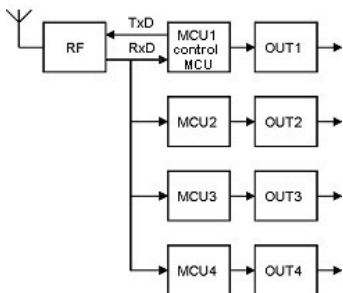

Fig. 4 Central unit block diagram

(RF) sensors, describing at the same moment also a reconstruction of the digital data received back in 4 impulse signal in the format which is identical with the original output of the appropriated sensors. These actions are provided with the central processor unit, is composed of one RF module, 4 MCUs and 4 output drivers; see the bloc diagram on the Fig. 4. A serial extension-line from the RF module is distributed to all 4 MCUs. These four MCUs have been chosen by reason of preventing to "edge jitters" of the generated impulses because a simultaneous generating of the impulse edge on all of the outputs in the same moment with one MCU should not be possible to be mastered without certain time errors, however imperceptible they may be. One MCU in the central unit is master and behind that this MCU is generating impulses for one output, this MCU has to synchronize the communication, and herewith to control run of the whole measuring system. The other 3 MCUs are receiving information from the RF channel only, generating impulses into the remaining 3 outputs. The central unit must have a higher processor [5] troughput, therefore its frequency is tripled, being 14.7456 MHz. Then the central unit with the same setting of dividers and timer clocks and in accordance to the identical rules and

formula, would translate this numerical value back on the impulses with the same frequency, which appears on the output of the wind sensors.

C. A concrete solution example of the HW part and measuring process algorithmen

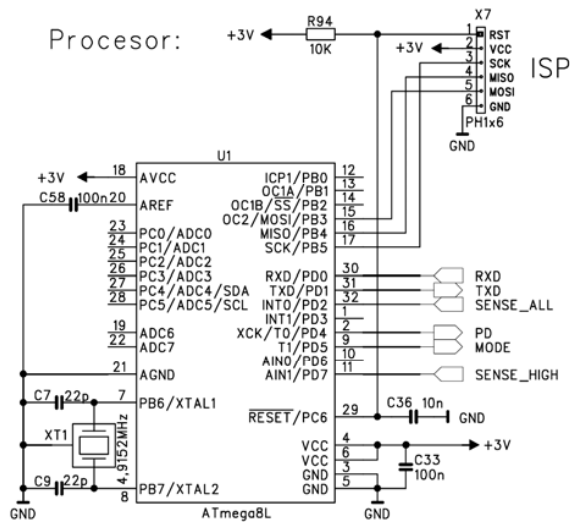

Fig. 5 Atmega8L Micro-controller wiring

A wiring diagram of the MCU smart sensor is presented on the Fig. 5. The inputs SENSE_HIGH...detection of higher amplitude impulses (wind direction) and SENZE_ALL ... detection of all impulses (wind speed) are important for this application, PC output and MODE output are of service for the XTR-903 transceiver mode control (a mode of communication and transmission testing). The terminals RxD and TxD are providing duplex communication of the MCU with the transceiver. The flow charts on the Fig. 6 are recording a solution of the important parts of measuring process (serial communication and real time generating are not included).

Comparative measurements with Quad and Yagi aerial signal coverage

Comparative measurements with the Yagi aerials and standardly used Quad type aerials have been performed. In the course of the comparative measurement, the signal level and measuring error rate depending on a distance of the sensor and measuring central have been measured. The standard aerials Quad taken from METEOS Ap-EL and 443/4P type Yagi aerial have been tested. Within the measurement, the aerials have been placed on metal grounded bars, the measurement has been performed for aerial to ground distances of 2m and 0.75m. The measurement has been performed on the equal unenclosed terrain. Either the program correct responses on error states (communication errors, errors of received data format) have been watched and verified in the course of this measurement.

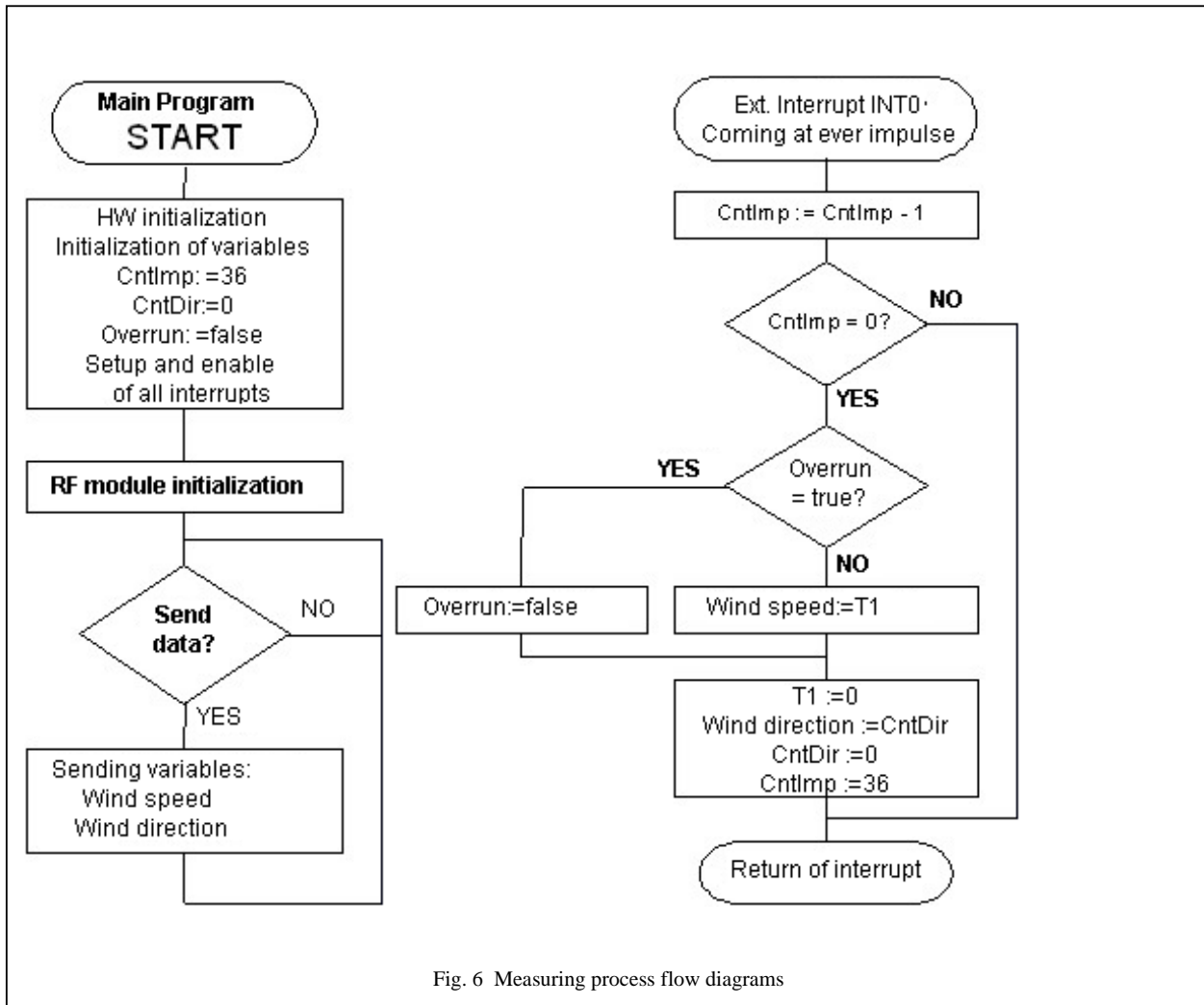

Fig. 6 Measuring process flow diagrams

Error rate Er enumeration has been performed in accordance with an usual formula:

$$Er = \frac{N_e}{N} \cdot 100 \quad (4)$$

Where N_e is a number of invalid measurements and N is a total number of measurements. In a case, when the aerials are placed on the level of 2m over ground, a maximum usable coverage of the measuring system with the Quad aerial was 235m, and with Yagi 410m, at longer distances, the signal level is declining while the measurement error rate is growing (see the Fig. 7). When placing the aerials on a lower level over ground, then the usable coverage is shortening, for the height 0.75m, 150m has been achieved with Quad aerials and 270m with Yagi aerials.

IV. CONCLUSION

The smart sensor development described in the article is a small part of the resolved problem only. It presents a modern wireless data transmission from sensor with an „embedded“

intelligence. The sensors have been realized practically and verified, they are a part of the measuring systems used in the research of wind erosion effect in VUMOP Prague (Research Institute for Soil and Water Conservation).

ACKNOWLEDGEMENT

The financial support of the Grant Agency of the Academy of Sciences of the Czech Republic (project No. 102/08/0424) is highly acknowledged.

REFERENCES

- [1] Stankovic JA, Abdelzaher TE, Lu C, Sha L, Hou JC, Real-time communication and coordination in embedded sensor networks, P IEEE 91(7) 2003,pp.:1002–1022,
- [2] Bhargava A, Zoltowski M, Sensors and wireless communication for medical care, Proc of the 14th International Workshop on Database and Expert Systems Applications, 2003,pp. 1–5.
- [3] Sivrikaya F, Yener B, Time synchronization in sensor networks: A survey, IEEE Network 18(4), 2004 pp.45–50.
- [4] AUREL S.P.A., Modigliana, Italy, (2003): Multichannel Micro Embedded Transceiver XTR-903-A8,

http://www.superrobotica.com/download/S350_190/XTR-903-A8_um.pdf

- [5] ATMEL (1995): ATmega8L - 8-bit with 8K Bytes In-System Programmable Flash, http://www.atmel.fi/dyn/resources/prod_documents/doc2486.pdf
- [6] Bohuslavěk Z.: Software Development for Mobile wireless Measuring System, In: Management of Production Systems with support of Information Technologies and Control Engineering, Nitra 2009, p.256-262.

Z. Bohuslavěk was born on 19th May 1947 in Prague. Education: CUA in Prague, Faculty of Engineering, 1972. He received the Ph.D degree in Automation at the CUA in Prague 1972, Habilitation in 1996 - Sensors and Measurement systems. He was appointed Professor of Automation and electronics in 2005. He is currently a Professor of automation and measurements systems at Faculty of Engineering, Czech University of Life Sciences Prague (CUA), Department of electrical engineering and automation. He teaches courses on Automation and Sensors. Author of 34 papers in journals, 18 contributions on the conference proceedings. Main objective: Electronic measurement systems, Sensors.

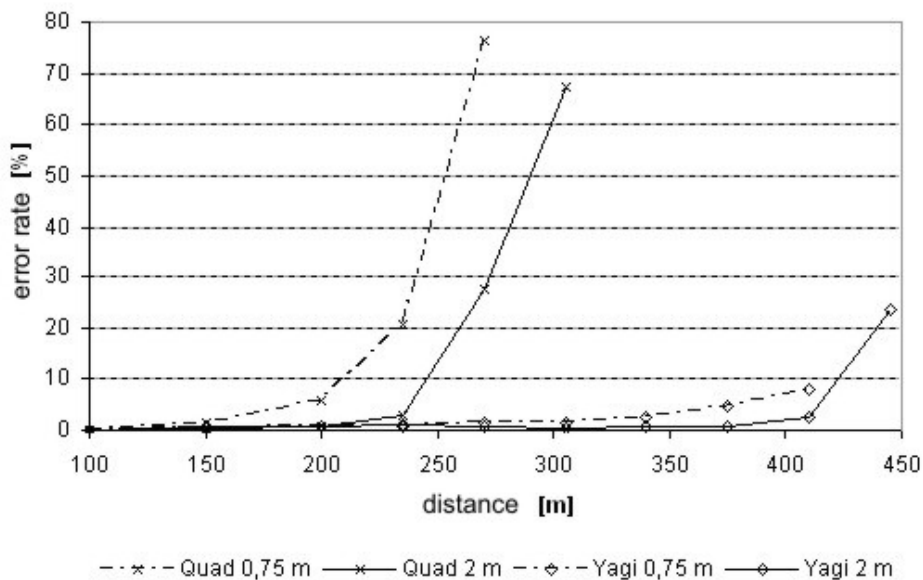

Fig.7 Error rate E_r dependence on the sensor – central unit distance