

Wearable Sensing Application- Carbon Dioxide Monitoring for Emergency Personnel Using Wearable Sensors

Tanja Radu, Cormac Fay, King Tong Lau, Rhys Waite, and Dermot Diamond

Abstract—The development of wearable sensing technologies is a great challenge which is being addressed by the Proetex FP6 project (www.proetex.org). Its main aim is the development of wearable sensors to improve the safety and efficiency of emergency personnel. This will be achieved by continuous, real-time monitoring of vital signs, posture, activity, and external hazards surrounding emergency workers. We report here the development of carbon dioxide (CO₂) sensing boot by incorporating commercially available CO₂ sensor with a wireless platform into the boot assembly. Carefully selected commercially available sensors have been tested. Some of the key characteristics of the selected sensors are high selectivity and sensitivity, robustness and the power demand. This paper discusses some of the results of CO₂ sensor tests and sensor integration with wireless data transmission

Keywords—Proetex, gas sensing, wireless, wearable sensors, carbon dioxide

I. INTRODUCTION

IN recent years, wearable sensing technologies have received much attention [1]-[6]. Several large European Union funded projects (Biotex, Wealthy, MyHeart, and Stella) have been focused on smart textiles, flexible wearable systems and their applications. The Proetex project joins European experts from universities, research institutions, and companies, combining expertise in textile engineering, medicine, wearable bioengineering, electronics, and communications. It is focused on multiple sensor integration issues, dealing with aspects of monitoring, communication and power management. Research team from the CLARITY CSET (www.clarity-centre.com) hosted in National Centre for Sensor Research (NCSR) at Dublin City University (DCU) are involved in development of toxic gas chemical sensing technologies and their integration into wearable platforms.

Protection of emergency personnel is especially important in the context of fire or rescue operations [7]. Proetex aims to improve safety of emergency-disaster workers by monitoring: i) operator's health status, ii) hazards in the surrounding

Tanja Radu, Cormac Fay, King Tong Lau and Dermot Diamond are with CLARITY: The Centre for Sensor Web Technologies, National Centre for Sensor Research, School of Chemical Sciences, Dublin City University, Dublin, Ireland (corresponding author : Dermot Diamond: 353-1-700-5404; fax: 353-1-700-8021; e-mail: Dermot.Diamond@dcu.ie).

Rhys Waite is with Zarlink Semiconductor Ltd, UK, (e-mail: Rhys.Waite@Zarlink.Com).

environment, which potentially can have harmful effect to health. Good communication is essential in these situations and is achieved in two ways: i) local communication between personnel within the affected area, ii) long-range communication with personnel outside of the affected area.

Carbon dioxide is commonly present in the atmosphere in concentrations ~400 ppm [8]. Increased concentrations of CO₂ in the atmosphere occur due to human activities such as the combustion of fossil fuels. When present in high concentrations, it poses a risk to human health and may lead to serious physiological effects due to oxygen deprivation which can result in permanent brain damage, coma and even death. It is imperative for the health and operational effectiveness of a fire fighter that he/she is not over-exposed to CO₂, and if exposed, the person is allowed to go to a secure space and breathe clean air to detoxify. Critical in this identification of toxification is a reliable method for monitoring CO₂ exposure.

This paper reports the fabrication of a CO₂ sensing boot that is capable of real time measurement and wireless data transmission to the control system.

II. PROTOTYPE DEVELOPMENT

A. Sensor Selection and Signal Conditioning

When adapting sensors as wearable devices for emergency personnel, special attention must be paid to the sensor's size and its position on body, since it must not obstruct the wearer's activities.

We have chosen an appropriate sensor based on its sensitivity, robustness and power demand. For the applications and working environments in which these devices will be deployed, potentiometric CO₂ sensor (Alphasense Ltd, Essex, UK) [9] was selected as the sensor of choice. These sensors don't have high power demand and high cost of NDIR sensors. For example, CO₂-D1 sensors are currently (May 2009) available at cost of 29 EUR, while NDIR sensors reach price of several hundreds of euro. New generation miniaturized D-series CO₂ sensors have diameter of 14.3 mm, and height of 13 mm (4 mm pins and 9 mm for sensor housing). These sensors contain reference and working electrodes, which are placed in an electrolyte that provides a reference CO₂ concentration. The measured potential is based on the difference in concentration between the reference electrode and the outside air. The sensor gives an accurate

reading for concentrations ranging from 100 ppm to more than 90% CO₂. This provides for accurate detection of both low concentration levels of CO₂ (that may be hazardous over long exposure times) and high concentrations that pose immediate danger. The sensors lifetime is up to 12 months.

The CO₂ analogue signal conditioning schematic used for building wireless sensing module is shown in Fig. 1. CO₂ sensor was attached to the wireless module and placed inside of the specially designed boot pocket (shown at Fig. 2).

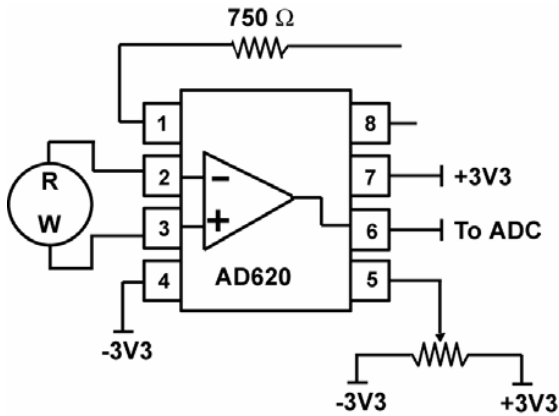

Fig. 1. CO₂ sensor analogue signal conditioning schematics. W/R represents the working/reference electrodes of the actual sensor

The sensors output ranges from -30mV to +30mV [9]. The 12-bit ADC channel on the wireless module reads from 0 to 2.4 V, giving a single step voltage of $2.4/2^{12} \approx 0.6$ mV. Given the small resolution range of the sensor output and allowing for noise, analogue signal conditioning is necessary. The signal is amplified by the configuration in Fig. 1. A voltage output range of (-30 to +30)*G mV results for full scale deflection range compatible with ADC channel of the wireless module. The output of this will obviously result in a negative voltage. To allow for this, one must have a negative power supply and offset (achieved by the potential divider).

B. Power Supply

Currently sensors are powered by a nickel metal hydride rechargeable battery (supplied by Varta), connected to the circuit through a 3 pin header. It supplies power for approximately 5 hours. Operating voltage range is from 3V (discharged) to 3.7V (charged).

C. Wireless Transmission

Wireless transmission is achieved using a 2,4 GHz Zigbee module with an integrated ceramic antenna- Jennic JN5139-001-M00 802.15.4 RF Module [10]. This short-range communication module has up to 1 km range [10]. Currently, the signal is received by a base station (Jennic JN5139 RF Module sensor board) connected to a PC and monitored using HyperTerminal.

The wireless sensing module shown at Fig. 2 contains the integrated CO₂ circuitry, CO₂ sensor, battery and the Zigbee module. The module will be placed into specially designed protective casing before being placed inside of the boot pocket.

D. Testing Methodology

Since CO₂ gas is denser than air, it tends to accumulate at lower layers. This is why it was decided to integrate the CO₂ sensor into a firefighter's boots. Special pocket was designed to enclose CO₂ sensor along with the wireless sensing module and a battery (see Fig. 2). The pocket has a water proof membrane that protects the sensor from water, but allows gas to pass through. The sensor was attached directly to a wireless sensing module and tested in 2 ways:

- i) The sensor was attached to a wireless sensing module and enclosed in a small air-tight testing chamber. It was exposed to a range of CO₂ concentrations (atmospheric to 42800 ppm), to test its response over the full calibration range for this application. Since the sensor's signal was wirelessly transmitted to a PC, this also enabled us to test the wireless connection.
- ii) The sensor was connected to a wireless sensing module, enclosed in a boot pocket; the boot was placed in large testing chamber and a single injection of known volume of pure CO₂ was injected. This enabled us to simulate a real-life situation and monitor the sensor's dynamic response. The sensors response was monitored using the base station's output in HyperTerminal on a remote PC.



Fig. 2. Firefighter's boot with built-in pocket used for enclosing the CO₂ sensor and wireless sensing module. Right: sensor attached onto the electronic platform module

III. RESULTS

In the small testing chamber, sensors were calibrated in the CO₂ range from atmospheric to 42800 ppm. The Fig. 3 shows a typical profile (raw data) obtained wirelessly from a 4-step sensor calibration. Note that sensors' response is not linear, but logarithmic. The sudden decrease of signal at the end of calibration curve corresponds to chamber being opened and the sensor re-exposed to atmospheric CO₂.

The output data from the sensor module was compared to those obtained by directly connecting CO₂ sensor to a multimeter. The results indicate that the wireless sensing module performed satisfactorily and the sensors responded accurately to CO₂.

A series of successful calibrations was performed. Fig. 4 shows two calibration plots obtained from a single sensor. Note that data is shown only using the wireless module. The results show that the slope is consistent with the manufacturer's specifications (10 mV per decade of CO₂ concentration) and the reproducibility is good in replicate measurements.

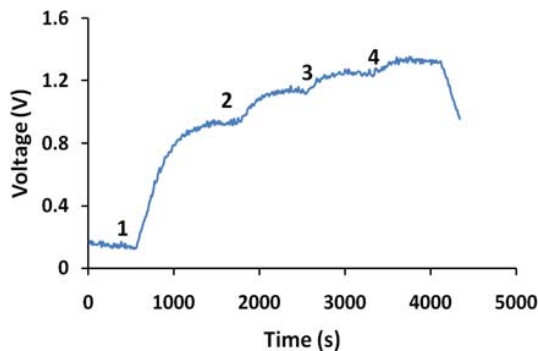

Fig. 3. Response profile of a 4-step calibration, from atmospheric (initial base line) to (1) 9750 ppm, (2) 19500 ppm, (3) 29300 ppm, and (4) 42800 ppm CO₂

The sensor module was tested in the boot which was placed inside a large chamber and one single injection of CO₂ was introduced, resulting in a concentration of 11400 ppm. Results of three replicates of this experiment for a single sensor are shown in Fig. 5.

Note that the slopes decreased when sensor was placed in a boot pocket with a waterproof membrane, due to the concentration gradient and slower diffusion through the membrane. Therefore it is important to keep the same type of membrane in future designs of the boot, as changing the type of membrane may directly affect the sensor's performance. Overall, the sensors show very good repeatability, as shown in Fig. 5.

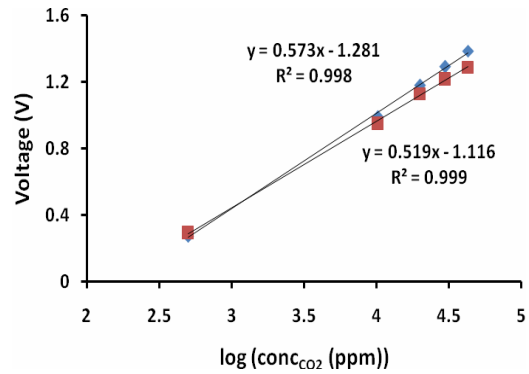

Fig. 4. Two calibrations performed using a single sensor with wireless module. Calibration range: atmospheric to 42800 ppm

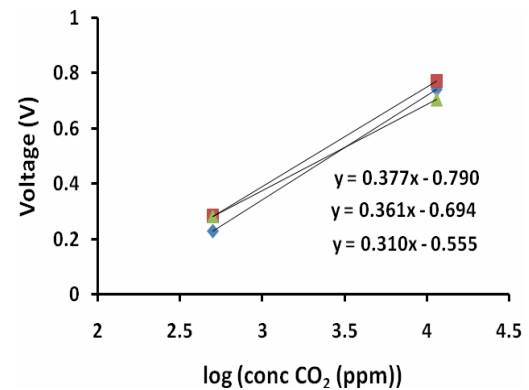

Fig. 5. Three replicates for a single sensor showing the effect of raising the CO₂ concentration from atmospheric to 11400 ppm in a single step - sensor enclosed in a boot pocket

IV. CONCLUSIONS

The results from this research shows a chemical sensor can be successfully integrated into a wearable platform and provide wireless monitoring of a hazardous gas (CO₂) in the environment surrounding emergency-disaster workers. Obtaining this information through continuous, real-time monitoring can clearly help in improving these workers safety and efficiency.

V. ACKNOWLEDGEMENTS

The authors gratefully acknowledge the financial support of the European Union (Proetex FP6-2004-IST-4), the Bristol Meyer Squibb, and the Science Foundation Ireland (07/CE/I1147). Also, we thank to Diadora-Invicta Group (Italy) for providing the testing boot.

REFERENCES

- [1] D. Diamond, "Internet-scale sensing". *Analytical chemistry*, 2004. 76(15): p. 278A-286A.
- [2] D. Diamond, K.T. Lau, S. Brady, and J. Cleary, "Integration of analytical measurements and wireless communications-Current issues and future strategies". *Talanta*, 2008. 75(3): p. 606-612.
- [3] P. Bonato, "Advances in wearable technology and applications in physical medicine and rehabilitation". *Journal of NeuroEngineering and Rehabilitation*, 2005 2:2.
- [4] D. Diamond, S. Coyle, S. Scarmagnani, and J. Hayes, "Wireless sensor networks and chemo-/biosensing". *Chemical reviews*, 2008. 108(2): p. 652-679.
- [5] S.P. Jayaraman, "Enhancing the quality of life through wearable technology". *Engineering in Medicine and Biology Magazine, IEEE*, 2003. 22(3): p. 41-48.
- [6] L.G. Paradiso R. , Taccini N., *Wearable System for Vital Signs Monitoring in Studies in health technology and informatics*. 2004, IOS Press. p. 253-259.
- [7] S. Brady, L.E. Dunne, A. Lynch, B. Smyth, and D. Diamond, "Wearable Sensors? What is there to sense?" *Studies in health technology and informatics*, 2005. 117: p. 80-88.
- [8] D.S. Robertson, "Health effects of increase in concentration of carbon dioxide in the atmosphere". *Current Science*, 2006. 90(12): p. 1607-1609.
- [9] Alphasense Ltd, *Solid state-carbon dioxide sensor Doc. Ref. TDS/CO2/ Issue 2 2008*; Available from: www.alphasense.com.
- [10] Jennic Ltd, *Product Brief – JN5139-xxx-Myy. 2008*; Available from: www.jennic.com.