

# Wavelet-Based Data Compression Technique for Wireless Sensor Networks

P. Kumsawat, N. Pimpru, K. Attakitmongcol and A.Srikaew

**Abstract**—In this paper, we proposed an efficient data compression strategy exploiting the multi-resolution characteristic of the wavelet transform. We have developed a sensor node called “Smart Sensor Node; SSN”. The main goals of the SSN design are lightweight, minimal power consumption, modular design and robust circuitry. The SSN is made up of four basic components which are a sensing unit, a processing unit, a transceiver unit and a power unit. FiOStd evaluation board is chosen as the main controller of the SSN for its low costs and high performance. The software coding of the implementation was done using Simulink model and MATLAB programming language. The experimental results show that the proposed data compression technique yields recover signal with good quality. This technique can be applied to compress the collected data to reduce the data communication as well as the energy consumption of the sensor and so the lifetime of sensor node can be extended.

**Keywords**—Wireless sensor network, wavelet transform, data compression, ZigBee, skipped high-pass sub-band.

## I. INTRODUCTION

WIRELESS sensor networks (WSN) is a self-organized distributed intelligent system comprising low-cost, low-power, multifunctional sensor nodes that are small in size and communicate with each other in short distances. The development of such networks was originally motivated by military applications such as battlefield surveillance. Recently, a lot of research related WSN have been conducted and people have been realizing their unlimited applicability. For example, WSN can be used for data collection purposes in situations such as environment and habitat monitoring, healthcare applications, home automation, structural monitoring, and equipment diagnostics. However, WSN face many challenges, mainly caused by communication failures, limited storage capability and computational constraints and limited power supply. Therefore, the technology of WSN is requiring more extensive research and development before it becomes practical.

In previous work, Watthanawisuth et al. [1] proposed a GPS tractor tracking system using ZigBee multi-hop mesh network for data communicate in the farm. The system can help farmer for managing and reducing the resources for tractor or other vehicles in the farm.

P. Kumsawat and N. Pimpru are with the School of Telecommunication Engineering, Institute of Engineering, Suranaree University of Technology, Nakhon Ratchasima, 30000, Thailand (phone: +66-4422-4392; fax: +66-4422-4603; e-mail: prayoth@sut.ac.th).

K. Attakitmongcol and A. Srikaew are with the School of Electrical Engineering, Institute of Engineering, Suranaree University of Technology, Nakhon Ratchasima, 30000, Thailand.

Data compression is a process that reduces the amount of data in order to reduce data transmitted and/or decreases transfer time. Due to the limited processing and storage resources of the sensor nodes, data compression in sensor nodes requires the simple and lightweight algorithms. In recent years, people have done a lot of research work on data compression algorithm and proposed many compression algorithms for WSN [2]. In [3], Kulakov and Davcev proposed data acquisition through hierarchical two-level architecture with algorithms using wavelets for initial data-processing of the sensory inputs and neural-networks using unsupervised learning for categorization of the sensory inputs. This architecture provides a big dimensionality reduction and in the same time additional communication saving, since only classification IDs (small binaries) are passed to the cluster head instead of all input samples. In [4], Gohet al. proposed the compression of neuronal recordings in real-time using a novel discriminating Linde-Buzo-Gray algorithm (DLBG) that preserves spike shapes while filtering background noise. The technique is implemented in a low power digital signal processor (DSP) which is capable of wirelessly transmitting raw neuronal recordings. Depending on the signal to noise ratio of the recording, the compression ratio can be tailored to the data to maximally preserve power and bandwidth. In [5], Nasri et al. proposed a signal compression approach in WSN consisting of technique to skip computation of certain high-pass coefficients of the discrete wavelet transform (DWT) called SHPS (Skipped High-Pass Sub-band). The simulation results show that the proposed scheme optimizes network lifetime, reduces significantly the amount of required memory and computation energy. In [6], Kimura and Latifi proposed five different types of data compression schemes which have been specifically designed for WSN: coding by ordering, pipelined in-network compression, JPEG2000, low-complexity video compression, and distributed compression. Even though those compression schemes are still under development, experimental results indicate that their compression rate and power reduction manners are quite impressive. In [7], Chichi et al. proposed new data compression algorithm inspired from Run Length Encoding called K-RLE. The authors also evaluate and compare compression algorithms on an ultra-low power microcontroller from Texas Instrument within the MSP430 series used for designing wireless sensor networks.

Recently, the wavelet-based approach has attracted much attention from researchers due to simplicity and high compression performance. In [8], Nasri et al. proposed an alternative image transmission approach in WSNs, based on

JPEG2000 image compression standard. This approach is based on discrete wavelet transform (DWT) and embedded block coding with optimized truncation (EBCOT) which uses a better order of transmission. Performance of the proposed image compression scheme is investigated with respect to image quality and energy consumption.

In [9], Manhas et al. proposed an efficient image transmission strategy exploiting the multi-resolution characteristic of DWT. The authors use selective decodes-and-forward (SDF) cooperation. The experimental results show that the overall energy consumption can be considerably reduced, with a negligible decrease on the average image quality. In [10], Rajput et al. provided a brief survey of advantage of using WSN in agriculture. The challenge in using WSN for apple farming is discussed. In [11], Kohvakka et al. proposed a mathematical performance analysis and simulations of IEEE 802.15.4 LR-WPAN in a large-scale WSN application with up to 1560 nodes. The network is formed in a beacon enabled cluster-tree topology according to ZigBee specification. The performance of a device and a coordinator are analyzed in terms of the average power consumption and throughput. In [12], an extensive survey of computational intelligence applications to various problems in WSN from various research areas and publication venues is presented in the paper.

In this paper, we propose a signal compression approach in WSN, based on wavelet transform called SHPS. This approach does not require computing high-pass coefficients in order to reduce the number of executed operations and therefore save computation energy used during the wavelet compression process. We have developed embedded software implementations based on the compression algorithm described in [5]. Due to its simplicity, this algorithm is very fast and can be easily implemented. The computational blocks in these realizations are implemented in the Simulink model and MATLAB programming language. We also implement the hardware of the smart sensor node using various components.

## II. PRELIMINARIES

### A. Wavelet Transform

The wavelet transform has received a tremendous amount of interest in many signal processing and image processing applications. The principle objective of the wavelet transform is to hierarchically decompose an input signal into a series of successively lower frequency approximation signal and their associate detail signal. Suppose  $\phi(t)$  and  $\psi(t)$  are the scaling function and the corresponding wavelet respectively with finite support  $[0, l]$ , where  $l$  is a positive number. It is well known that  $\phi(t)$  and satisfies the following dilation equation:

$$\phi(t) = \sqrt{2} \sum_{k=-\infty}^{\infty} h(k)\phi(2t-k) \quad (1)$$

and

$$\psi(t) = \sqrt{2} \sum_{k=-\infty}^{\infty} g(k)\psi(2t-k) \quad (2)$$

where the  $h(k)$  and  $g(k)$  are constants called low- and high-pass filter coefficients, respectively. We will use the following standard notations:

$$\phi_{j,k}(t) = 2^{-j/2}\phi(2^{-j}t-k) \quad (3)$$

$$\psi_{j,k}(t) = 2^{-j/2}\psi(2^{-j}t-k) \quad (4)$$

Each wavelet  $\psi_{j,k}(t)$  is generated by translating and dilating of function  $\psi(t)$  called mother wavelet.

Consider the subspace  $V_j$  of  $L^2$  defined by;

$$V_j = \text{Span} \{ \phi_{j,k}, k \in \mathbb{Z} \} \quad (5)$$

and the subspace  $W_j$  of  $L^2$  defined by

$$W_j = \text{Span} \{ \psi_{j,k}, k \in \mathbb{Z} \} \quad (6)$$

the subspaces  $V_j, -\infty < j < \infty$ , form a multi-resolution of  $L^2$  with the subspace  $W_j$  being the difference between  $V_j$  and  $V_{j+1}$ . In fact, the  $L^2$  space has or the normal decomposition as;

$$L^2 = V_j \oplus \sum_j W_j \quad (7)$$

In most practical applications, one never explicitly calculates the scaling function  $\phi(t)$  and wavelet function  $\psi(t)$  but performs the transform using the scaling coefficients  $h(k)$  and the wavelet coefficients  $g(k)$ . In forward wavelet analysis, a  $J$ -level discrete decomposition can be written as

$$\begin{aligned} f(t) &= \sum_n c_{0,n} \phi(t-n) \\ &= \sum_k c_{j,k} \phi_{j,k}(t) + \sum_{j=1}^J \sum_k d_{j,k} \psi_{j,k}(t) \end{aligned} \quad (8)$$

where the coefficients  $c_{j,k}$  and  $d_{j,k}$  at resolution  $j$  are related to the coefficients  $c_{j-1,k}$  at level  $j-1$  by the following recursive equations:

$$c_{j,k} = \sum_n c_{j-1,k} h(n-2k) \quad (9)$$

$$d_{j,k} = \sum_n c_{j-1,k} g(n-2k) \quad (10)$$

for  $j=1, 2, \dots, J$ . In (8), the first summation gives a function that is a low resolution or coarse approximation of  $f(t)$ , which represents the smooth part of  $f(t)$ . For each increasing level  $j$  in the second summation, a higher or fine resolution function is added, which represents the detail part of  $f(t)$ .

In backward wavelet synthesis, a reconstruction of the original fine scale coefficients of the signal can be made from a combination of the scaling coefficients and wavelet coefficients at a coarse resolution. Because all of these functions are or the normal, we have

$$c_{j-1,k} = \sum_n c_{j,n} h(k-2n) + \sum_n d_{j,k} g(k-2n) \quad (11)$$

The synthesis operation of (11) is equivalent to up-sampling the coefficients  $c_{j+1,n}$  and  $d_{j+1,n}$  in the coarser level  $j+1$ , and then convolving with  $h(k)$  and  $g(k)$ , individually, to obtain the scaling coefficients in the finer level  $j$ . The synthesis process can be recursively continued to the original level. The analysis and synthesis procedures lead to the pyramid-structured wavelet decomposition [13]. The block diagrams of a wavelet decomposition and reconstruction are shown in Fig. 1, where  $H(z)$  and  $G(z)$  are the  $z$  transform of  $h(k)$  and  $g(k)$ , respectively.

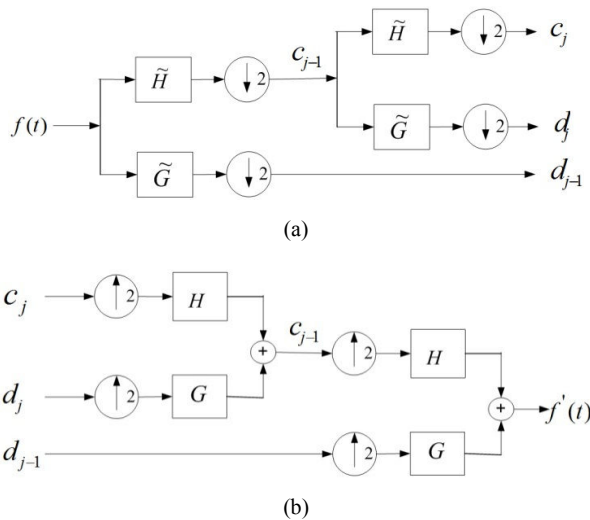

Fig. 1 The block diagrams of two-level wavelet (a) decomposition and (b) reconstruction

**B. ZigBee**

ZigBee is a specification for a suite of communication protocols based on the IEEE 802.15.4-2003 standard, which targets wireless personal area networks. We note that ZigBee operates in the network layer using as a transport layer. These services are provided by the IEEE 802.15.4-2003 protocol. Actually, the IEEE 802.15.4 defines two physical layers which operate in three frequencies. The physical layer operates at 2.4

GHz with a maximum transfer rate of 250 kbps. There are no restrictions for using this band around the world.

There exist three types of ZigBee devices as follows:

- The ZigBee Coordinator (ZC): This is the most powerful ZigBee device. The coordinator can be seen as the root of the network topology and it can also be utilized as a gateway to other piconets. Sometimes, the coordinator is used as a trust entity that can maintain the system's key repository.
- ZigBee Router (ZR): This device can execute a common application and can work as intermediate router in order to send data to other ZigBee devices.
- ZigBee End Device (ZED): This device has limited functionalities such as exchanging information with the ZC or the ZR devices. A ZED cannot forward data to other devices. The main feature of this device is that it keeps the device stay in the low-power consumption mode most of the time. This allows the saving of significant battery life time. This device requires less amount of memory and is the cheapest ZigBee device.

Example of a network of ZigBee devices and the comparison of several wireless sensor network technologies are shown in Figs. 2 and 3, respectively.

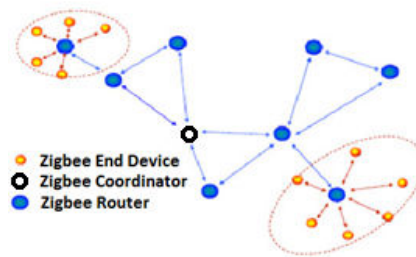

Fig. 2 Example of a network of ZigBee devices

Network Technology	Wi-Fi	Bluetooth	UWB	Zigbee
Cost	Higher	Lower	Highest	Lowest
Battery Life	Several days	Several days	Several hours	Several years
Effective range	100m	10m	30m	10~75m
Transmission Rate	5.5/11 Mbit/s	1~3 Mbit/s	40~600 Mbit/s	20/40/250 Kbit/s
Adoption agreement	802.11b	802.15.1		802.15.4
Communication channels	2.4GHz	2.4GHz	3.1~10.6 GHz	868MHz/ 915MHz/ 2.4GHz

Fig. 3 Comparison of several wireless sensor network technologies

**III. PROPOSED METHOD**

In this section, we first give a brief overview of the WSN embedded system architecture and signal compression algorithm in the wavelet transform domain. The main motivation of our work is based on the idea proposed in [5]. The computational blocks in these realizations are implemented in the Simulink model and MATLAB

programming language. We also implement the hardware of the WSN using various components.

*A. WSN Embedded System Architecture*

Fig. 4 shows diagram of a wireless mesh network. Mesh is one of many network topologies and forms inherently the most reliable and scalable network. Each node has routing capabilities and not only passes on packets but also decides which is the best path and ignores any broken nodes.

In Fig. 5, the main controller of the SSN is the FiO Std evaluation board [14]. The microcontroller unit (MCU) is ARM 32-bits Cortex™-M3 processor (STM32F103RET6). It contains also read only memory (ROM), random access memory (RAM), a 12 bit analog to digital convertor (ADC), a 12 bit digital to analog convertor (DAC), timer and few comparators. We have integrated sensors such as relative temperature and humidity sensor, light sensor, soil moisture sensor to the FiO Std evaluation board. The temperature and relative humidity sensor is Sensirion SHT11 with accuracy of  $\pm 0.4^{\circ}C$  and 3% on the temperature and humidity, respectively. This sensor is connected to the MCU through the I<sup>2</sup>C interface. Other analog sensors, such as soil moisture sensor and light sensor can be easily connected to the ADC interface of the MCU. The SSN is powered by solar panel with 10.0 W. The RF module is ZigBee and takes responsibility of transferring data in the networks. A high power integrated module which covers distance range up to 1.5 Km is suitable for farmland monitor.

*B. Wavelet-Based Signal Compression Algorithm*

Signal compression is a process that reduces the amount of data in order to reduce data transmitted. Numerous of signal compression techniques have been developed in the past few years, and the wavelet transform techniques have already achieved great success in the signal compression field. The wavelet transform is a time-scale analysis. The signal is analyzed at multiple frequency ranges with different resolutions by decomposing the signal into a coarse approximation and detail information.

In order to save computation energy, we propose a wavelet-based signal compression approach in WSN which does not require computation of certain high-pass coefficients of the discrete wavelet transform. This technique is called “Skipped High Pass Sub-bands; SHPS” [5]. Following the same process given in [5], we use Mallat’s pyramid algorithm [13] to implement the DWT. The resulting wavelet coefficients are then encoded using the SHPS technique.

Fig. 6 illustrates the distribution of low-pass coefficients (approximation coefficients) and high-pass coefficients (detail coefficients) after applying 1-level Haar wavelet transform to the temperature signal. The low-pass coefficients represent approximation of the original signal whereas the high-pass coefficients represent detail information of the original signal. We notice that the high-pass coefficients are generally small. Based on the numerical distribution, we can estimate the high-pass coefficients to be zeros and hence avoid computing them. The reconstruction signal without using the high-pass

coefficients is shown in Fig. 6 (d).The computational blocks in these realizations are implemented in the Simulink model as shown in Fig. 7.

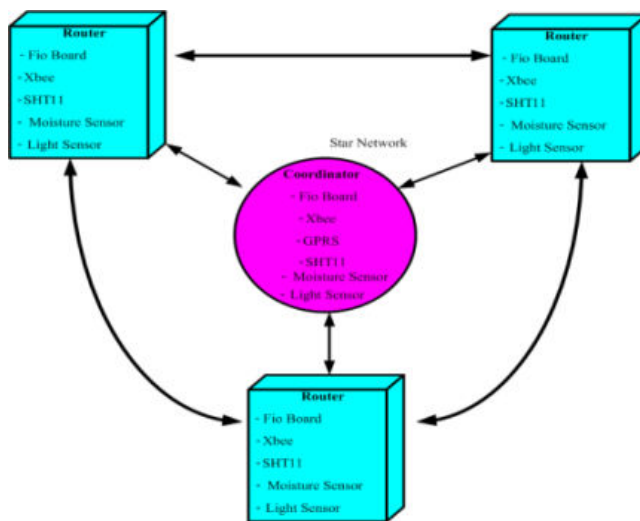

Fig. 4 Diagram of a wireless mesh network

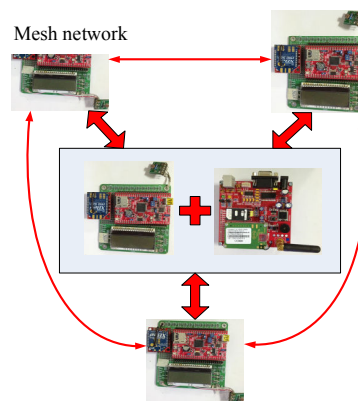
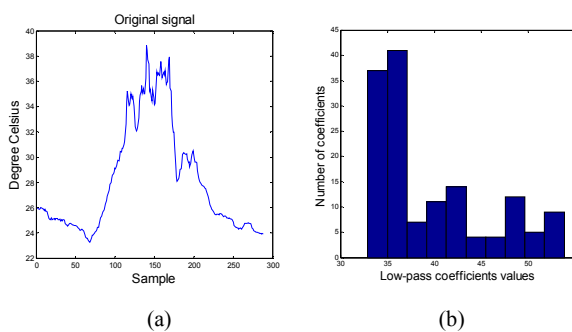

Fig. 5 Implementation of a wireless mesh network



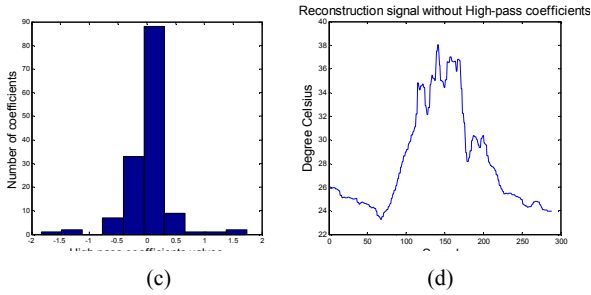

Fig. 6 (a) Original signal (b) numerical distribution of low-pass coefficients (c) numerical distribution of high-pass coefficients and (d) reconstructed signal without using high-pass coefficients

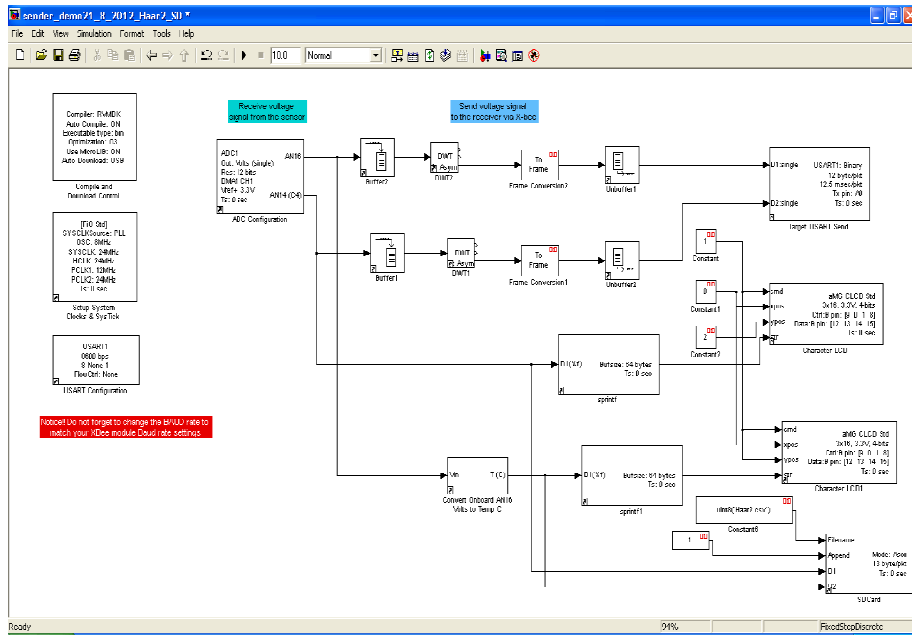

Fig. 7 Simulink model

IV. EXPERIMENTAL RESULTS AND DISCUSSIONS

In order to evaluate the performance of the signal compression algorithm based on discrete wavelet transform, we use MATLAB as simulation tool. To demonstrate the effectiveness of our proposed method, a series of experiments have been conducted. The compression ratio (*CR*), percentage root mean square difference (*PRD*) and quality factor (*QF*) are used as performance measures to quantify the difference between the original signal and the processed signal[15].

The compression performance of the proposed algorithm is evaluated in terms of the *CR* which is defined as the ratio of the amount of uncompressed data size to the amount of compressed data size. The *CR* is defined as;

$$CR = \frac{\text{Uncompression size}}{\text{Compression size}} \quad (12)$$

In WSN signal compression, quality of the reconstructed signal is an important issue. In this paper, the *PRD* is usually used for quality criterion. The *PRD* is defined as;

$$PRD = \sqrt{\frac{\sum_{n=1}^N (x[n] - \hat{x}[n])^2}{\sum_{n=1}^N x^2[n]}} \times 100\% \quad (13)$$

where  $x[n]$  and  $\hat{x}[n]$  denote the original and reconstructed data, respectively, and  $N$  is the number of samples within one data segment. Finally, *QF* is defined as;

$$QF = \frac{CR^2}{PRD} \quad (14)$$

A. Result of Software Simulations

For performance evaluation, four kinds of time series data, namely ambient temperature, light intensity, relative humidity

and the moisture content of soil are selected as the experimental data series, with different data fluctuation characteristic. They are collected by four mesh nodes at 5 minutes intervals from a farm at Suranaree University of Technology. The length of each data series takes 288 points and they are shown in Fig. 8.

The choice of wavelet is important in decomposition process and the selected wavelet should be simple and feasible for implementation in a resource-limited MCU. In addition, the fundamental of choosing low-frequency coefficients is to select them in an appropriate decomposition level. As a result, we investigate the choice of the most appropriate mother wavelet for SHPS signal compression technique. We have tested 3 wavelets: Haar, Daubechies's type 4 (DB4) and Daubechies' type 8 (DB8). The SHPS technique has been carried out using single level, 2-level and 3-level wavelet decomposition. In this section, we used time series data, and measured the  $CR$ ,  $PRD$  and  $QF$  of the compressed signal. The results are presented in Fig. 9. It can be seen from Fig. 9 that the choice of mother wavelet and decomposition level have effect on the  $CR$ ,  $PRD$  and  $QF$  of the compressed signal.

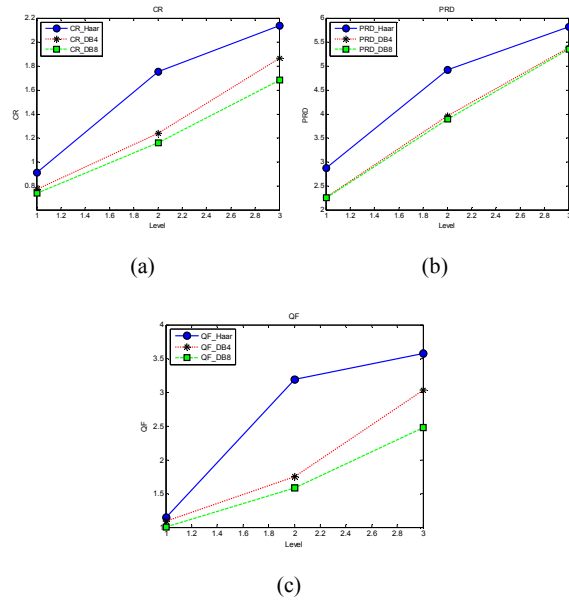

Fig. 9 (a)  $CR$  (b)  $PRD$  and (c)  $QF$  as a function of the mother wavelet and decomposition level

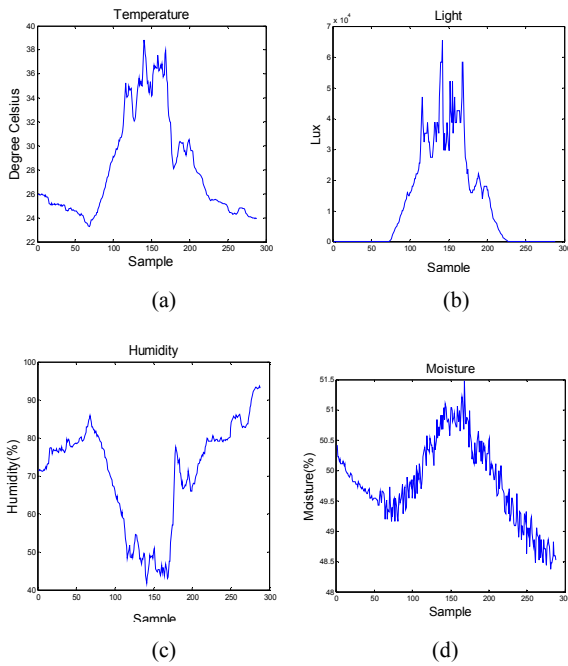

Fig. 8 Original signals used in simulations (a) temperature, (b) light, (c) humidity and (d) moisture

The experiments also demonstrate that the SHPS technique allows us to choose signal quality of wireless service by changing the number of wavelet decomposition levels. Thus, there will be a tradeoff between the signal quality and computation complexity because the more levels of wavelet decomposition, the algorithm performs, the more computational time it takes. In this work, Haar wavelet at 2-level decomposition has been chosen for this implementation.

**B. Result of Hardware Implementation**

In this experiment, we demonstrate the efficiency of this scheme under real-world applications with limited number of data samples. The four SSNs were deployed in a farmland environment, all within single-hop range of the receiver device. The compression and transmission is done automatically at the SSN base station. After compressing, the compressed data is transmitted to the web server. However, the transmission to the web server can be wired or wireless based on the application and necessity.

The comparison of the original signal and the recovery signal of the temperature and light intensity at the compression ratio 1.7 are shown in Fig. 11 and Fig. 12, respectively. It is obviously shown that the compressed data can be reconstructed effectively. Although some of the reconstructed data has some difference from the original data, there is almost no influence on the data series and the total trends of data series are well illustrated. Therefore, the algorithm proposed in this paper can be applied to compress the collected data and reduce the data communication as well as the energy consumption of the SSN so that the lifetime of SSN can be extended.

**V. CONCLUSIONS**

This paper proposed an efficient data compression strategy exploiting the multi-resolution characteristic of the wavelet transform. We have developed a sensor node called "Smart Sensor Node; SSN". The main goals of SSN design are lightweight, minimal power consumption, modular design and robust circuitry. The SSN is made up of four basic components which are a sensing unit, a processing unit, a transceiver unit and a power unit. FiO Std evaluation board is chosen as the main controller of the SSN for its low costs and

high performance. The software coding of the implementation was done using Simulink model and MATLAB programming language. The experimental results show that the proposed compression algorithm yields recover signal with good quality. Further research can be concentrated on the development of the optimization technique of compression algorithm by using the artificial intelligent techniques.



Fig. 10 SSN base station (Coordinator) installation in SUT farm

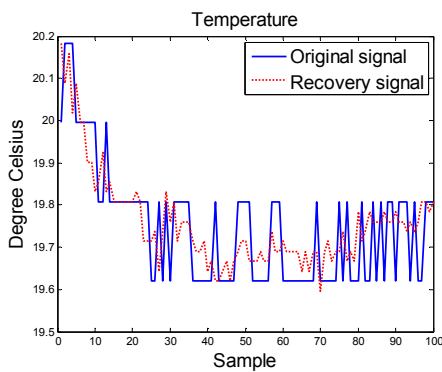

Fig. 11 Comparison of the original signal and the recovery signal of temperature with  $N = 64$

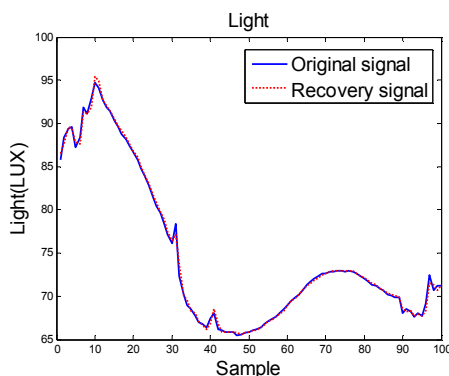

Fig. 12 Comparison of the original signal and the recovery signal of light intensity with  $N = 64$

#### ACKNOWLEDGMENT

This work was supported by a grant from SUT Research and Development Fund, Suranaree University of Technology, Nakhon Ratchasima, Thailand.

#### REFERENCES

- [1] N. Watthanawisuth, N. Tongrod, T. Kercharoen and A. Tuantranont, "Real-Time Monitoring of GPS-Tracking Tractor Based on ZigBee Multi-Hop Mesh Network," In Proc. the Electrical Engineering/Electronics Computer Telecommunications and Information Technology, Vol. 1, pp. 580-583, 2010.
- [2] N. Kimura and S. Latifi, "A Survey on Data Compression in Wireless Sensor Networks," In Proc. the Information Technology: Coding and Computing, Vol. 2, pp:8 – 13, 2005.
- [3] A. Kulakov and D. Davcev, "Intelligent Data Acquisition and Processing Using Wavelet Neural Networks," In Proc. IEEE Workshop on Intelligent Data Acquisition and Advanced Computing Systems: Technology and Applications, Vol. 1, pp. 491-494, 2005.
- [4] A. Goh, S. Craciun, S. Rao, D. Cheney, K. Gugel, J. C. Sanchez, J. C. Principe, "Wireless Transmission of Neuronal Recordings Using a Portable Real-Time Discrimination/Compression Algorithm," In Proc. the 30th Annual International Conference on Engineering in Medicine and Biology Society, pp:4439 – 4442, 2008.
- [5] M. Nasri, A. Helali, H. Sghaier, and H. Maaref, "Energy-Efficient Wavelet Image Compression in Wireless Sensor Network," In Proc. the Communication in Wireless Environments and Ubiquitous Systems: New Challenges (ICWUS), pp. 1 – 7, 2010.
- [6] N. Kimura and S. Latifi, "A survey on data compression in wireless sensor networks," In Proc. the Information Technology: Coding and Computing, Vol. 2, pp:8 – 13, 2005.
- [7] E. Chichi, H. Guyennet and J. Friedt, "K-RLE : A New Data Compression Algorithm for Wireless Sensor Network," In Proc. the 2009 Third International Conference on Sensor Technologies and Applications, Vol. 1, pp. 502-507, 2009.
- [8] M. Nasri, A. Helali, H. Sghaier and H. Maaref, "Adaptive image transfer for wireless sensor networks (WSNs)" In Proc. 2010 International Conference on Design & Technology of Integrated Systems in Nanoscale Era, Vol. 1, pp:1 – 6, 2010.
- [9] E. Manhas, G. Brante, R. Souza and M. Pellenz, "Energy-Efficient Cooperative Image Transmission Over Wireless Sensor Networks," In Proc. the 2012 IEEE Wireless Communications and Networking Conference : Mobile and Wireless Networks, Vol. 2, pp. 2014-2019, 2012.
- [10] N. Rajput, N. Gandhi and L. Saxena, "Wireless Sensor Networks: Apple farming in Northern India," In Proc. 2012 Fourth International Conference on Computational Intelligence and Communication Networks, Vol. 1, pp. 218-221, 2012.
- [11] M. Kohvakka, M. Kuorilehto, M. Hännikäinen and T. D. Hämäläinen, "Performance Analysis of IEEE 802.15.4 and ZigBee for Large-Scale Wireless Sensor Network Applications" In Proc. the 3rd ACM international workshop on Performance evaluation of wireless ad hoc, sensor and ubiquitous networks, Vol. 1, pp.45-48, 2006.
- [12] R. V. Kulkarni and G. K. Venayagamoorthy, "Computational Intelligence in Wireless Sensor Networks: A Survey," IEEE Communications Surveys & Tutorials, Vol. 13, No. 1, pp. 68-96, 2011.
- [13] S.G. Mallat, "A Theory for Multiresolution Signal Decomposition: The Wavelet Representation," IEEE Trans. Pattern Anal. Mach. Intell. Vol. 11, pp. 674-693, 1989.
- [14] FiO Std evaluation board web site, <https://www.aimagin.com/fio-std.html>.
- [15] B. Arvinti, C. Nafornita, I. Alexandru and M. Costache "ECG Signal Compression Using Wavelets. Preliminary Results," In Proc. 2011 10th International Symposium on Signals, Circuits and Systems, Vol. 1, pp. 1-4, 2011.



**P. Kumsawat** was born in Maehongson, Thailand, in 1969. He received the B.Eng. degree in electrical engineering from the Royal Thai Air Force Academy, Bangkok, Thailand, in 1994, the M.Eng. degree in electrical engineering from Kasetsart University, Bangkok, Thailand, in 1997 and Ph.D. degree in electrical engineering from Suranaree University of Technology,

Nakhon Ratchasima, Thailand, in 2006. Since 1999, he has been with the Institute of Engineering, Suranaree University of Technology, Nakhon Ratchasima, Thailand, where he is currently an Assistant Professor in the School of Telecommunication Engineering. His research interests include digital signal processing, image processing, wavelet transform, multiwavelet transform, artificial Intelligence, and embedded systems.



**N. Pimpru** was born in Nakhon Ratchasima, Thailand, in 1989. She received the B.Eng. degree in telecommunication engineering from Suranaree University of Technology, Nakhon Ratchasima, Thailand, in 2011. She is currently working toward the M.Eng. degree in the School of Telecommunication Engineering, Institute of Engineering, Suranaree University of Technology, Nakhon Ratchasima,

Thailand. Her research interests include signal processing, wireless sensor networks and artificial intelligence.



**K. Attakitmongcol** was born in Satun, Thailand, in 1972. He received the B.Eng. degree in electronics engineering from King Mongkut's Institute of Technology, Ladkrabang, Bangkok, Thailand, in 1994 and the M.S. and Ph.D. degrees, both in electrical engineering, from Vanderbilt University, Nashville, TN, in 1996 and 1999, respectively. Since 1999, he has been with the Institute of Engineering, Suranaree University of Technology,

Nakhon Ratchasima, Thailand, where he is currently an Associate Professor in the School of Electrical Engineering. His research interests include digital signal processing, image processing, wavelet transform, and multiwavelet transform.



**A. Srikaew** was born in Ubol Ratchathani, Thailand, in 1972. He received the B.Eng. degree from King Mongkut's Institute of Technology Ladkrabang, Bangkok, Thailand, in 1994 and the M.S. and Ph.D. degrees, both in electrical engineering, from Vanderbilt University, Nashville, TN, in 1997 and 2000, respectively. Since 2000, he has been with the School of Electrical Engineering, Institute of Engineering, Suranaree University of Technology, Nakhon Ratchasima,

Thailand, where he is currently an Associate Professor. His main research interests are in the area of computer and robot vision, image processing, neural networks, artificial Intelligence, and intelligent systems.