

Voltage Stability Assessment and Enhancement Using STATCOM - A Case Study

Puneet Chawla, Balwinder Singh

Abstract—Recently, increased attention has been devoted to the voltage instability phenomenon in power systems. Many techniques have been proposed in the literature for evaluating and predicting voltage stability using steady state analysis methods. In this paper P-V and Q-V curves have been generated for a 57 bus Patiala Rajpura circle of India. The power-flow program is developed in MATLAB using Newton Raphson method. Using Q-V curves the weakest bus of the power system and the maximum reactive power change permissible on that bus is calculated. STATCOMs are placed on the weakest bus to improve the voltage and hence voltage stability and also the power transmission capability of the line.

Keywords—Voltage stability, Reactive power, power flow, weakest bus, STATCOM.

I. INTRODUCTION

VOLTAGE stability is concerned with the ability of a power system to maintain acceptable voltage level at all nodes in the system under normal and contingent conditions. A power system is said to have a situation of voltage instability when a disturbance causes a progressive and uncontrollable decrease in voltage level. The voltage instability is usually caused by a disturbance or change in operating conditions, which create increased demand for reactive power [8]. This increase in electric power demand makes the power system work close to their limit conditions such as high line current, low voltage level and relatively high power angle differences which indicate the system is operating under heavy loading conditions. Such a situation may cause system losing stability, islanding or voltage collapse [1]. The main problem facing many utilities in maintaining adequate voltage level is economic. They are squeezing the maximum possible capacity for their bulk transmission network to avoid the cost of building new lines and generation facilities. When a bulk transmission network is operated close to the voltage instability limit, it becomes difficult to control the reactive power margin for that system [3]. As a result the system stability becomes one of the major concerns and an appropriate way must be found to monitor the system and avoid system collapse.

Many algorithms have been proposed in the literature for voltage stability analysis. Most of the utilities have a tendency to depend regularly on conventional load flows for such analysis [5]. Some of the proposed methods are concerned with voltage instability analysis under small perturbations in

system load parameters. The analysis of voltage stability, for planning and operation of a power system, involves the examination of two main aspects;

Many algorithms have been proposed in the literature for voltage stability analysis. Most of the utilities have a tendency to depend regularly on conventional load flows for such analysis. Some of the proposed methods are concerned with voltage instability analysis under small perturbations in system load parameters. The analysis of voltage stability, for planning and operation of a power system, involves the examination of two main aspects;

i) how close the system is to voltage instability i.e. Proximity and ii) the key contributing factors such as the weak buses, area involved in collapse and generators and lines participating in the collapse when voltage instability occurs i.e. Mechanism of voltage collapse [9]. Proximity can provide information regarding voltage security while the mechanism gives useful information for operating plans and system modifications that can be implemented to avoid the voltage collapse.

Various techniques are available for voltage stability studies such as P-V curves, Q-V curves, modal analysis, minimum singular value, sensitivity analysis, reactive power optimization, artificial neural networks, neuro-fuzzy networks, reduced Jacobian determinant, Energy function methods, Thevenin and load impedance indicator and loading margin by multiple power-flow solutions [2]. The introduction of Flexible AC Transmission System (FACTS) controllers [16] are increasingly used to provide voltage and power flow controls. Insertion of FACTS devices is found to be highly effective in preventing voltage instability [17]. Owing to high cost, the number of FACTS devices to be used should be minimized.

II. P-V AND Q-V CURVES

The P-V i.e. active power-voltage curves are the most widely used method of predicting voltage security. They are used to determine the MW distance from the operating point to the critical voltage. The method of maximum power transfer [1] determines critical limits on the load bus voltages, above which the system maintains steady-state operation. Q-V or voltage- reactive power curves are generated by series of power flow simulation. They plot the voltage at a test bus or critical bus versus reactive power at the same bus. The bus is considered to be a PV bus, where the reactive output power is plotted versus scheduled voltage. Most of the time these curves are termed Q-V curves rather than V-Q curves. Scheduling reactive load rather than voltage produces Q-V curves. These curves are a more general method of assessing voltage

Puneet Chawla and Balwinder Singh are Assistant Professor in Department of Electrical Engineering, PEC University of Technology, Chandigarh (e-mail: puneetishaan@yahoo.co.in, balwindersingh@pec.ac.in).

stability. They are used by utilities as a workhorse for voltage stability analysis to determine the proximity to voltage collapse and to establish system design criteria based on Q and V margins determined from the curves.

In normal operating condition, an operator will attempt to correct the low voltage condition by increasing the terminal voltage. However, if the system is operating on the lower portion of the curve, the unstable region, increasing the terminal voltage will cause an even further drop in the load voltage.

III. P-MARGIN CALCULATION BY P-V CURVES

The P-V curve of a single, constant power load connected through a transmission line to an infinite-bus is shown in Fig. 1. Consider the solution of the power-flow equations, where P, the real power of the load, is taken as a parameter that is slowly varied, and V is the voltage of the load bus. The three regions shown in Fig. 1 are related to the parameter P. In the first region, the power flow has two distinct solutions for each choice of P; one is the desired stable voltage and the other is the unstable voltage. As P is increased, the system enters the second region, where the two solutions intersect to form one solution for P, which is the maximum. If P is further increased, the power-flow equations fail to have a solution. This process can be viewed as a bifurcation of the power-flow problem. The method of maximum power transfer determines critical limits on the load bus voltages, above which the system maintains steady-state operation. The P-V curve is drawn for the load bus and the maximum transmissible power is calculated. Each value of the transmissible power corresponds to a value of the voltage at the bus until $V = V_{crit}$ after which further increase in power results in deterioration of bus voltage. The top portion of the curve is acceptable operation whereas the bottom half is considered to be the worsening operation. The risk of voltage collapse is much lower if the bus voltage is further away, by an upper value, from the critical voltage corresponding to Pmax. Hence, the P-V curve can be used to determine the system's critical operating voltage and collapse margin [11], [12].

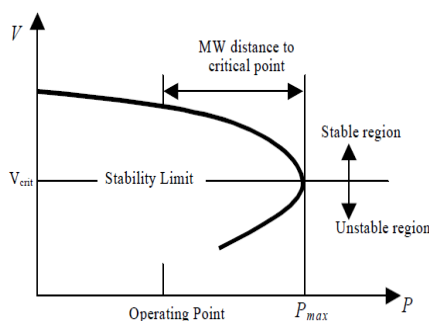

Fig 1 Real Power-Voltage (P-V) curve

IV. Q-MARGIN CALCULATION BY Q-V CURVES

The Q-V curves, reactive power- voltage curve, are used to determine the Mvar distance from the operating point to the critical voltage [10]. A typical Q-V curve is shown in Fig. 2. It shows the sensitivity and variation of bus voltages with respect to reactive power injections or absorptions. Scheduling reactive loads rather than voltage produces Q-V curves. These curves are a more general method of assessing voltage stability. They are used by utilities as a workhorse for voltage stability analysis to determine the proximity to voltage collapse and to establish system design criteria based on Q and V margins determined from the curves. Operators may use the curves to check whether the voltage stability of the system can be maintained or not take suitable control actions. As a traditional solution in system planning and operation, the voltage level is used as an index of system voltage instability [13]. If it exceeds the limit, reactive support is installed to improve voltage profiles. With such an action, voltage level can be maintained within acceptable limits under a wide range of MW loadings. In reality, voltage level may never decline below that limit as the system approaches its steady state stability limits. Consequently, voltage levels should not be used as a voltage collapse warning index.

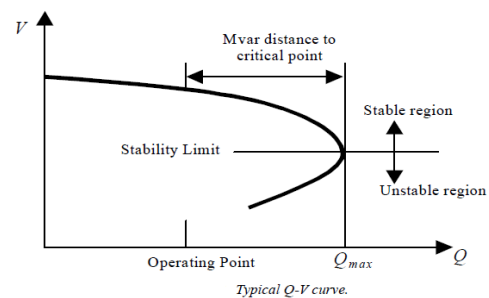

Fig. 2 Reactive power –voltage (Q -V) curve

In Fig. 2, the Q axis shows the reactive power that needs to be added or removed from the bus to maintain a given voltage at a given load. The reactive power margin is the Mvar distance from the operating point to the bottom of the curve. The curve can be used as an index for voltage instability. Near the nose of a Q-V curve, sensitivities get very large and then reverse sign [14]. Also, it can be seen that the curve shows two possible values of voltage for the same value of power. The power system operated at lower voltage value would require very high current to produce the power. That is why the bottom portion of the curve is classified as an unstable region; the system cannot be operated, in steady state, in this region. The top portion of the curve represents the stability region while the bottom portion from the stability limit indicates the unstable operating region. It is preferred to keep the operating point far from the stability limit [15].

V. FACTS

FACTS is an evolving technology based solution envisioned to help the utility industry to deal with changes in the power

delivery business [19]. FACTS is defined by the IEEE as “a power electronic based system and other static equipment that provide control of one or more AC transmission system parameters to enhance controllability and increase power transfer capability [3], [20]. FACTS provide high speed and precise control of one or more AC system parameters within synchronous AC system, thereby greatly enhancing the value of AC transmission assets. These parameters include voltages, impedances, phase angle, currents, reactive power and active power [4]. The Static Synchronous Compensator (STATCOM) is based on the principal that a voltage source inverter generates a controllable AC voltage source behind a transformer reactance so that the voltage difference across the reactance produces active and reactive power exchange between the STATCOM and the transmission network [6]. The STATCOM is a shunt reactive power compensating electronic device that generates AC voltage, which intern causes a current of variable magnitude at the point of connection [18]. This injected current is almost in quadrature with the line voltage, thereby emulating an inductive or a capacitive reactance at the point of connection with the transmission line. This is useful to generate or absorb reactive power for regulating the line voltage of the bus where the STATCOM is connected [7].

VI. A CASE STUDY

In the present study, P-V and Q-V curves for various load buses of the 57-bus system of Patiala-Rajpura circle of PSPCL have been generated by series of power-flow solutions [16]. The power-flow program is developed in MATLAB environment using Newton-Raphson method to obtain the power-flow solution. This program computes the voltage magnitude and voltage angle at each bus in a power system. Real power and reactive power flows for all equipment interconnecting the buses, as well as equipment losses, are also computed. It displays the active and reactive power flow entering the line terminals and line losses as well as the net power at each bus. This program requires the line and transformer parameters and transformer tap settings specified. It converts impedance to admittance and obtain the bus admittance matrix. The program is designed for the direct use of load and generation in MW and Mvar, bus voltage in per unit, angle in degrees. Loads and generation are converted to per unit quantities on the MVA selected. The program is used to find every bus's active and reactive powers separately in a certain interval transfer, voltage value against them and determine P-V and Q-V curves. It takes into account the reactive power limits of generators in the systems. The power-flow solution of the system is taken as a base case. Q-V curves are developed based on the following methodology.

1. Choose a load bus at which the reactive power Q is incrementally increased. This could be a critical bus for contingency. The chosen bus is called the candidate bus.
2. The reactive power output of each generator should be allowed to adjust as the Q-V analysis progresses. Voltage

collapse occurs in the study region after the reactive power capability in the study region is depleted.

3. Increase the reactive power Q by 0.2 p.u. at the candidate bus. Run the power-flow program with this change. Obtain a new voltage value at the candidate bus against the increased Q value.
4. Iterate the processes at step 3 until the power flow does no more converge.
5. To reach the collapse point (the nose of the curve) closely, take the last case at which the power flow converges as the base case. Decrease the value of increment to 0.1 p.u. and execute steps 3 and 4.
6. Execute step 5, decreasing the value of increment to 0.05 p.u.
7. Run the program that plots the Q-V curve using the calculated voltages corresponding to incrementally changed Q values at the candidate bus.
8. Compute the Q margin, subtracting Q value at the base case from maximum reactive power Q_{max} , which is at the collapse point.



KEY DIAGRAM OF 220 KV GRID SUB STATION ABLOWAL

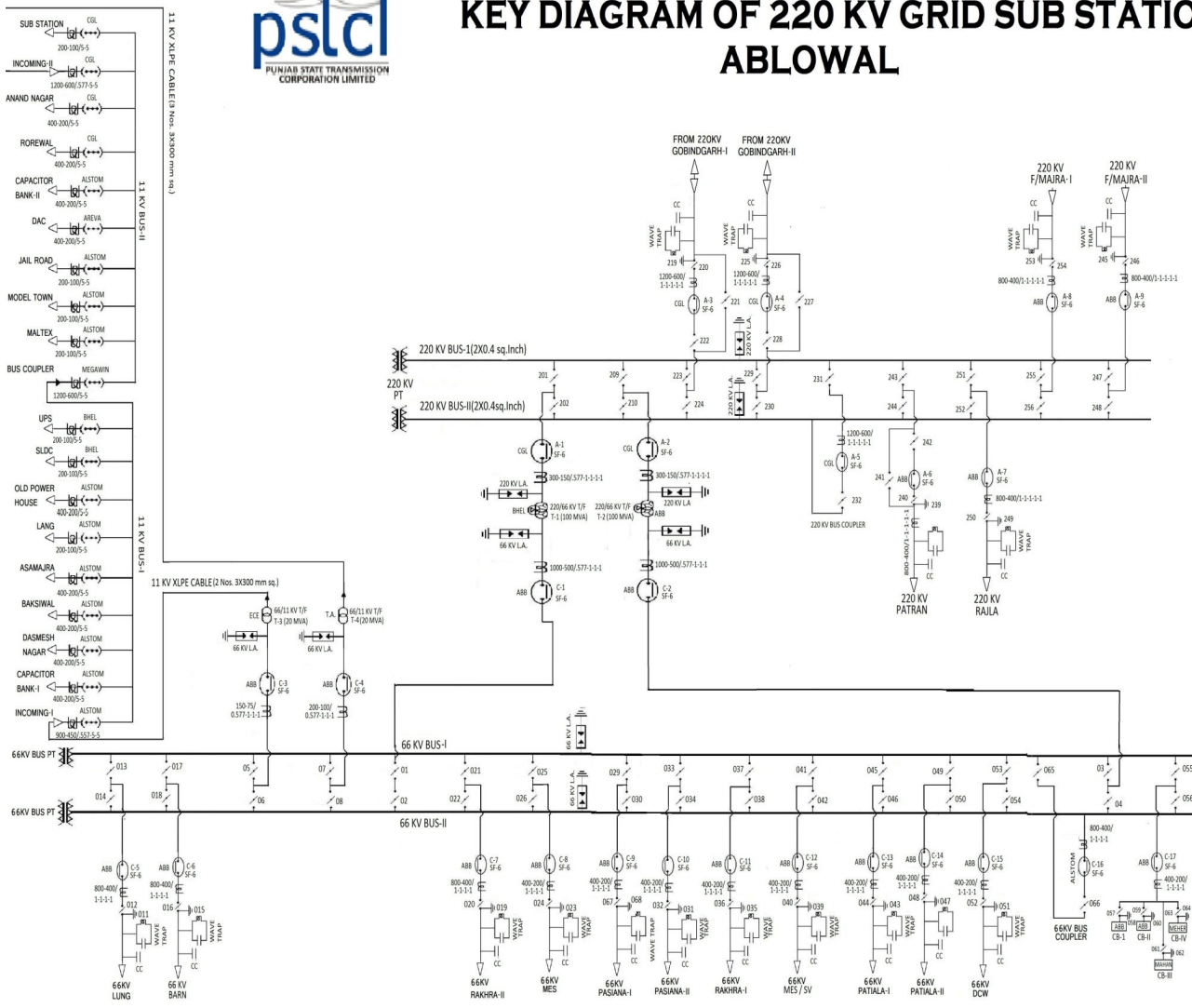

Fig. 3 Single line diagram of Rajpura Patiala circle

The Q-V curve of each bus is obtained and then $\partial V/\partial Q$ is calculated i.e ratio of of voltage drop with increase in reactive power. Then $\partial V/\partial Q$ for all buses is compared and bus having the largest ratio is the weakest bus. STATCOMs are placed on the weakest bus and voltage and reactive power is found.

VII. RESULTS

The $\partial V/\partial Q$ ratio is maximum for Bus no 53, so bus number 53 is the weakest bus of the system. In this case the bus voltage drops from 0.98 p.u. to 0.68 p.u. with a reactive power change of 0.45 p.u. Q-V curve of Bus No 53 is shown in Fig. 4.

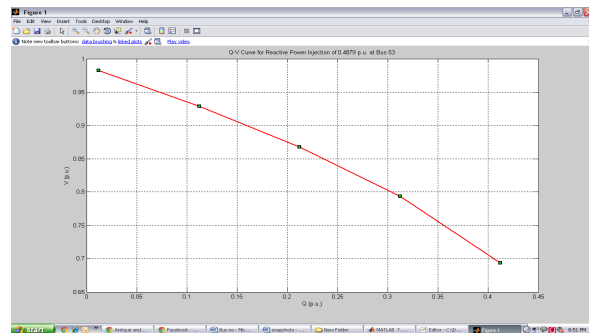

Fig. 4 Q - V curve of Bus 53

Similarly Bus no 7 is the second weakest bus and in this case the bus voltage drops from 1.01 to 0.67 p.u. with a reactive power change of 0.6 p.u. QV curve of Bus 7 is shown in Fig 5.

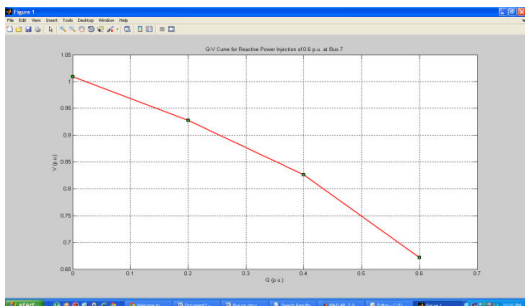

Fig. 5 Q -V curve of Bus 7

Also the voltage at Bus No 3 does not change even when the Reactive power is changed by 2 p.u. and thus it gives $\partial V/\partial Q = 0$ which shows that it is the most stable bus of the system. Q-V curve of Bus 3 is shown in Fig. 6.

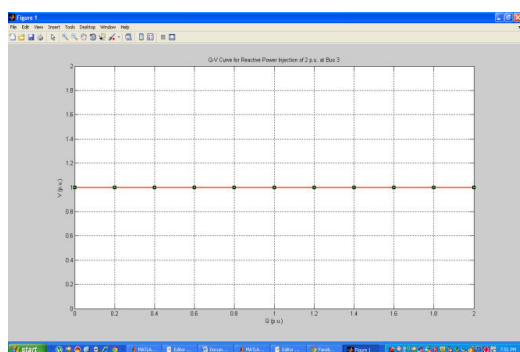

Fig. 6 QV curve of Bus 3

Similarly the bus voltage at Bus No 1 drops from 1.00 p.u. to 0.992 p.u. with change in Reactive power of 2 p.u. and giving $\partial V/\partial Q = 0.004$. Bus No 1 is the second most stable bus of the system. QV curve of Bus 1 is shown in Fig. 7

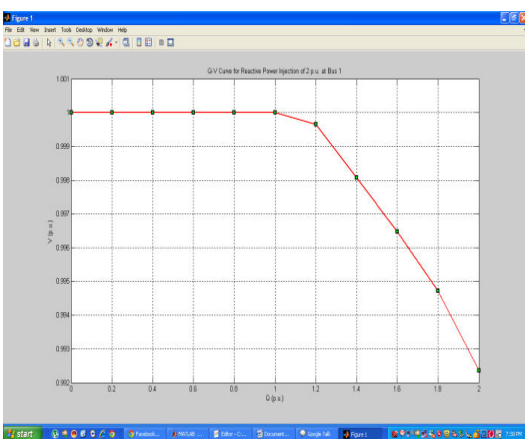

Fig. 7 QV curve of Bus 1

After finding the weakest bus, now we will use STATCOM to improve the voltage at the weakest bus. Increasing the voltage at the weakest bus improves the voltage stability and also the power transmission capability of the line.

Case 1

Initially the STATCOMs were placed at Bus No 53, 27 and 28 with Q_{smax} and Q_{smin} values of 1.0 p.u. and -1.0 p.u., the following table was obtained

TABLE I
VOLTAGE WITH STATCOM AT BUS NO. 53,28, 27

STATCOM at Bus No.	V_{sh} pu	θ degree	Q_{sh} pu
53	0.9102	13.8736	0.8978
28	0.9010	9.9414	0.9892
27	0.9464	11.4421	0.5356

Thus we see that with these positions of STATCOM, the voltage at Bus 53 which had fallen to 0.68 p.u. improves to 0.9102 with a Reactive power Injection of 0.8978 p.u.

Case 2

Now the position of STATCOMs was changed to Bus No 53, 52 and 27 with Q_{smax} and Q_{smin} values of 1.0 and -1.0 p.u. and the following table was obtained

TABLE II
VOLTAGE WITH STATCOM AT BUS NO. 53, 52, 27

STATCOM at Bus No.	V_{sh} Pu	θ degree	Q_{sh} pu
53	0.9314	14.1663	0.6861
52	0.9545	12.4665	0.4545
27	0.8941	11.8096	1.0582

It can be clearly seen that when the position of STATCOM is changed to a position nearest the weakest bus, then the voltage improves to 0.9314 p.u. with a lesser reactive power injection of 0.6861 p.u.

Case 3

Now the position of STATCOMs was changed to Bus No 53, 52 and 54 with Q_{smax} and Q_{smin} values of 1.0 and -1.0 p.u. and the following table was obtained

TABLE III
VOLTAGE WITH STATCOM AT BUS NO. 53,52,54

STATCOM at Bus No.	V_{sh} pu	θ degree	Q_{sh} pu
53	0.9747	14.3883	0.2530
52	0.9225	13.4586	0.7746
54	0.9279	13.3045	0.7204

It can be seen that at this position of STATCOM, the voltage at Bus 53 improves to 0.9747 p.u. with a reactive power injection of just 0.2530 p.u., which is least in the cases described above.

With further change in the positioning of STATCOM no increase in voltage at Bus 53 was found because the bus is connected to only Bus No 52 and Bus No 54 and the maximum value of voltage will thus be 0.9747 p.u. for this bus.

Cost being a major factor in prohibits us from using more than 3 STATCOMs for the line to enhance its voltage capability.

VIII. CONCLUSION

This work enhances the understanding of power systems network and power-flow calculations. To analyze the power

networks, a power-flow program is developed. It solves the power-flow problems of real power systems such as the power system of the Patiala Rajpura Circle of PSPCL. Q-V curves are generated automatically by running the curve plotting program we developed. Using these curves, the weakest bus of the power system and the maximum reactive power change permissible on that bus has been calculated. With the use of shunt FACTS device such as STATCOM, the Bus voltage of the weakest bus is improved and it is found that the positioning of the device nearest to the weakest bus improves the Voltage of the weakest bus by a greater value than if it is placed at other position on the system.

REFERENCES

- [1] C. Barbier and J. P. Barret, "Analysis of Phenomena of Voltage Collapse on a Transmission system," *Review Generale de l'Electricite*, vol. 89, pp. 672-690, Oct. 1980.
- [2] Miller T. J. E., editor, "Reactive Power Control in Electric Systems," *John Wiley & Sons*, New York, 1982.
- [3] Saadat H., "Power System Analysis," *McGraw-Hill International Editions*, vol 17, pp. 114-136, 2004.
- [4] Taylor C. W., "Power System Voltage Stability," *McGraw-Hill Inc.*, New York 1994.
- [5] Glover D. J. and Sarma M. S., "Power System Analysis & Design," *PWS Publishing Company*, Third Edition, 2001.
- [6] Machowski, Bialek and Bumby "Power System Dynamics and Stability" John Wiley & Sons Ltd, 1997.
- [7] Sirisuth, Piya "Voltage Instability analysis using the Sensitivity of Minimum Singular Value of Load Flow Jacobian" 1993.
- [8] Ajjarapu, V. and Lee, B. "Bibliography on Voltage Stability" IEEE Trans. on Power Systems, vol. 13, pp.115-125, 1998
- [9] Van Cutsem T. and Vournas C., "Voltage Stability of Electric Power Systems," *Springer*, Second Printing, 2008.
- [10] Bulent Aydin, "Voltage Security Assessment Using P-V and Q-V Curves," *Master Thesis*, T.C. Bahcesehir Universitesi, Istanbul, 2008.
- [11] Kundur P., "Power System Stability and Control," *McGraw-Hill Inc.*, New York, USA, 1994.
- [12] M.H.Haque, "Optimal location of shunt FACTS devices in long transmission line", *IEEE Proceedings on Generation Transmission & Distribution*, Vol.147, No.4, pp.218-22, 2000.
- [13] Chiang H. D., Wang C. S., and Flueck A. J., "Look-Ahead Voltage and Load Margin Contingency Selection Functions for Large-Scale Power Systems," *IEEE Transactions on Power Systems*, Vol.12, No. 1, pp. 173-180, Feb. 1997.
- [14] Chowdhury B. H. and Taylor C. W., "Voltage Stability Analysis: V-Q Power Flow Simulation versus Dynamic Simulation," *IEEE Transactions on Power Systems*, Vol.15, No. 4, pp. 1354-1359, Nov. 2000.
- [15] Bergen R., *Power Systems Analysis*. Prentice-Hall, New Jersey. 1986.
- [16] Canizares C.A., "Conditions For Saddle-Node Bifurcations In AC/DC Power Systems," *Int. J. of Electric Power & Energy Systems*, vol. 17, no. 1 February pp.:61-68, 1995.
- [17] N.G. Hingorani, EPR!, "Flexible AC Transmission System," *IEEE Spectrum power systems*, April 1993, pp. 40-45.
- [18] A. M. Gole, V.K. Sood, "A static Compensator model for use with Electromagnetic Transients simulation Programs," *IEEE Transactions on Power Delivery*, vol. 5, No.3, July 1990, pp. 1398 - 1407.
- [19] Cigre international conference on large high voltage Electric systems, "Facts Overview", IEEE Power Engineering Society April, 1995.
- [20] Dr. SA Khaparde, Mr. S.M. Brahma, "Flexible AC Transmission System (FACTS): An Overview", *Transmission and Distribution in 2000 Technical Conferences February 1996*. pp. 1-5.