

# Vector Control Using Series Iron Loss Model of Induction, Motors and Power Loss Minimization

Kheldoun Aissa, and Khodja Djalal Eddine

**Abstract**—The iron loss is a source of detuning in vector controlled induction motor drives if the classical rotor vector controller is used for decoupling. In fact, the field orientation will not be satisfied and the output torque will not track the reference torque mostly used by Loss Model Controllers (LMCs). In addition, this component of loss, among others, may be excessive if the vector controlled induction motor is driving light loads. In this paper, the series iron loss model is used to develop a vector controller immune to iron loss effect and then an LMC to minimize the total power loss using the torque generated by the speed controller.

**Keywords**—Field Oriented Controller, Induction Motor, Loss Model Controller, Series Iron Loss.

## I. INTRODUCTION

THE induction motor is designed to operate under constant voltage and frequency [1, 2]. That means when it is used as a variable speed drive, the motor will operate far from the optimum operating point. In fact, if the field oriented controller is used as a controller that is mostly used, the oriented flux will be maintained to its rated value which increases the power loss when the motor drives light loads. Energy saving in induction motor drives aims at controlling the motor to match the load requirements but with minimum power loss. So far, two main methods have been used to minimize the power loss within the induction motor drive whatever the decoupling control technique; search controllers [3, 4, 5] (SC) and loss model controllers [1, 6, 7, 8] (LMC). The SCs offers the advantage to be robust against the parameters variation but have a very sluggish response whereas the LMCs are very fast but parameters dependent. In other hand, for the LMCs to be more accurate, the model that will be used to derive the LMC algorithm must be extended to include all the power loss components, such as: stator and rotor iron losses, stray load losses, etc. For this reason, many papers have used the extended dq model that includes the iron loss components, which dominates the stray load losses, in order to get more precise LMCs. In this model, the iron loss is modelled by a resistance connected in parallel to the magnetizing inductance, however this approach has added two extra differential equations which needs extra calculations. In the present work, a series iron loss model is used to derive the field oriented controller and the LMC algorithm. A program is developed to testify the effectiveness of the proposed architecture in which the LMC feeds the modified

Kheldoun Aissa is with Systems and Signals Laboratory, Department of Electrical engineering and Electronics, Boumerdes University, Algeria (e-mail: aissa1973@gmail.com, fax:+21324818333).

Khodja Djalal Eddine is with M'sila University, Algeria.

field oriented controller by the optimal flux level and receives the required electrical speed of the oriented flux from it.

The paper is organized as follows, after a general introduction; the modelling of the induction motor is presented in section II where the series iron model is emphasized. The next section uses this model to derive to rotor field oriented controller equations. In section IV, the principal of Loss model controller is applied. First the total loss is quantified using the dq model and the field oriented control then the equation that generates the optimal flux as function of the operating point variables is derived. The obtained simulation results using MATLAB/SIMULINK package are discussed in section V. Finally we end up by a general conclusion and some suggestions for the future.

## II. DQ MODELLING OF INDUCTION MOTORS

A dynamic modelling of the induction motor has been widely studied in the literature. The six differential equations relating the stator and rotor voltages to the stator and rotor currents are reduced to four equations by using the famous park transformation. This transformation offers, besides simplification, the advantage to eliminate completely the time varying parameters. It's based on a set of hypothesis assumptions, among others symmetrical three phase machine and neglected saturation [2, 9]. In this model the iron loss has not been considered. As the present paper is focusing on the power loss minimization, this power loss component cannot be ignored. According to the literature, one can find two main approaches of modelling induction machine taking into account the iron loss, namely: parallel and series iron loss models.

### A) Parallel Iron Loss Modeling

In this model, the iron loss, including the loss due to eddy current and to hysteresis current, is represented by a resistance  $R_{fe}$ . The classical DQ model, represented by four differential equations, of the induction motor is modified by connecting this resistance in parallel to the magnetizing inductance. This modification results in a new dq model with six order differential equations, as explained in Levi *et al.* [10].

### B) Series Iron Loss Modelling

The series iron loss model has been derived from the parallel model by introducing some simplifications and assuming that the change rate of magnetizing current is ignored in comparison with that of stator current and rotor current as well [11], it follows that:

$$v_{ds}^e = R_s i_{ds}^e + L_{ls} di_{ds}^e/dt - \omega_e L_{ls} i_{qs}^e + L_M d(i_{ds}^e + i_{dr}^e)/dt - \omega_e L_M (i_{qs}^e + i_{qr}^e) + R_{ms} (i_{ds}^e + i_{dr}^e) \quad (1)$$

$$v_{qs}^e = R_s i_{qs}^e + L_s di_{qs}^e/dt + \omega_e L_s i_{ds}^e + L_M d(i_{qs}^e + i_{qr}^e)/dt + \omega_e L_M (i_{ds}^e + i_{dr}^e) + R_{ms} (i_{qs}^e + i_{qr}^e) \quad (2)$$

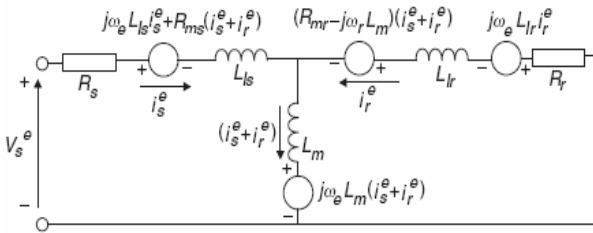

Fig. 1 IM modelling with series iron loss resistance

$$0 = R_r i_{dr}^e + L_r di_{dr}^e/dt - \omega_{sl} L_r i_{qr}^e + L_M d(i_{ds}^e + i_{dr}^e)/dt - \omega_{sl} L_M (i_{qs}^e + i_{qr}^e) + R_{mr} (i_{dr}^e + i_{ds}^e) \quad (3)$$

$$0 = R_r i_{qr}^e + L_r di_{qr}^e/dt - \omega_{sl} L_r i_{dr}^e + L_M d(i_{qs}^e + i_{qr}^e)/dt + \omega_{sl} L_M (i_{ds}^e + i_{dr}^e) + R_{mr} (i_{qr}^e + i_{qs}^e) \quad (4)$$

Where:

$$L_m(\omega_e, s) \approx L_M \quad (5)$$

$$R_{ms}(\omega_e, s) \approx \omega_e^2 (s^2 + 1) L_M^2 / R_M \quad (6)$$

$$R_{mr}(\omega_e, s) \approx \omega_{sl} \omega_e (s^2 + 1) L_M^2 / R_M \quad (7)$$

The equivalent circuit for series iron loss model of the IM in the rotating reference frame is represented in Fig. 1.

### III. FIELD ORIENTED CONTROL USING SERIES IRON LOSS MODEL

To apply the rotor field oriented control principal, the state vector must contain the rotor flux components. Thus the above equations of the induction motor are arranged by introducing the rotor flux defined by the followings:

$$\lambda_{dr}^e = L_r i_{dr}^e + L_M i_{ds}^e \quad (8)$$

$$\lambda_{qr}^e = L_r i_{qr}^e + L_M i_{qs}^e \quad (9)$$

By eliminating the rotor current components using (8) and (9) and replacing them in the induction motor model, we obtain the following:

$$V_{ds}^e = (R_s + L_r/L_r R_{ms} + \sigma L_s p) i_{ds}^e - \omega_e \sigma L_s i_{qs}^e + R_{ms}/L_r \lambda_{dr}^e + L_M/L_r d\lambda_{dr}^e/dt - \omega_e L_M/L_r \lambda_{qr}^e \quad (10)$$

$$V_{qs}^e = (R_s + L_r/L_r R_{ms} + \sigma L_s p) i_{qs}^e + \omega_e \sigma L_s i_{ds}^e + R_{ms}/L_r \lambda_{qr}^e + L_M/L_r d\lambda_{qr}^e/dt + \omega_e L_M/L_r \lambda_{dr}^e \quad (11)$$

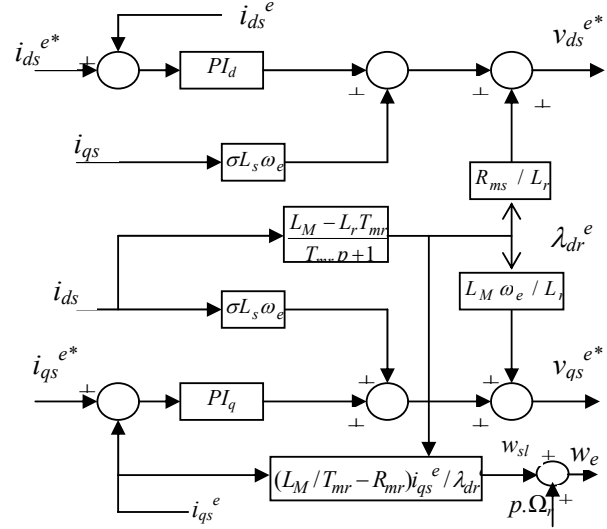

Fig. 2 Block diagram of the FOC derived from the series iron loss model

$$0 = (p + (R_r + R_{mr})/L_r) \lambda_{dr}^e - \omega_{sl} \lambda_{qr}^e +$$

$$[R_{mr} - L_M/L_r (R_r + R_{mr})] i_{ds}^e \quad (12)$$

$$0 = (p + (R_r + R_{mr})/L_r) \lambda_{qr}^e + \omega_{sl} \lambda_{dr}^e +$$

$$[R_{mr} - L_M/L_r (R_r + R_{mr})] i_{qs}^e \quad (13)$$

Where:  $p = d/dt$  and  $\sigma = (1 - L_M^2/L_r L_s)$ . By letting  $\lambda_{qr}^e = d\lambda_{qr}^e/dt = 0$ ,  $\lambda_{dr}^e =$  a constant [6, 7] and using the following notations  $T_{mr} = L_r/(R_{mr} + R_r)$ ,  $T_r = L_r/R_r$ ,  $R_s^* = R_s + R_{ms} L_r/L_r$ , we obtain the modified field oriented controller equations:

$$p i_{ds}^e = -(R_s^*/\sigma L_s) i_{sd}^e + \omega_e i_{qs}^e - (R_{ms}/\sigma L_s L_r) \lambda_{dr}^e + V_{ds}^e/\sigma L_s \quad (14)$$

$$p i_{qs}^e = -(R_s^*/\sigma L_s) i_{qd}^e - \omega_e i_{ds}^e - (L_M/\sigma L_s L_r) \lambda_{dr}^e + V_{qs}^e/\sigma L_s \quad (15)$$

$$\lambda_{dr}^e = [(L_M - T_{mr} R_{mr})/(T_{mr} p + 1)] i_{ds}^e \quad (16)$$

$$\omega_{sl} = (L_M/T_{mr} - R_{mr}) i_{qs}^e / \lambda_{dr}^e \quad (17)$$

The decoupling current control is achieved by:

$$V_{ds}^e = (K_p + K_i/p)(i_{ds}^{e*} - i_{ds}^e) - \omega_e \sigma L_s i_{qs}^e + (R_{ms}/L_r) \lambda_{dr}^e \quad (18)$$

$$V_{qs}^e = (K_p + K_i/p)(i_{qs}^{e*} - i_{qs}^e) - \omega_e \sigma L_s i_{ds}^e + (L_M/L_r) \omega_e \lambda_{dr}^e \quad (19)$$

Where:  $K_p, K_i$  are the proportional and integral gains and  $i_{ds}^{e*}, i_{qs}^{e*}$  denote the d- and q-phase current commands, respectively. The block diagram, shown in Fig. 2 summarizes the constitution of the modified FOC controller.

IV. POWER LOSS MINIMIZATION

Minimisation of the loss in the induction motor is directly related to the choice of the flux level. Choosing the level of flux in the induction motor remains an open problem from the perspective of maximising motor efficiency and many researchers continue to work on this problem, and numerous operation schemes have been proposed by many researchers concerning the optimal choice of excitation current or flux level for a given operating point.

In low-frequency operation, core loss (hysteresis and eddy current loss) is rather low compared with copper loss. As the speed goes up, however, the contribution of the eddy current loss increases and finally becomes dominant. Hence, the optimal combination of d-axis and q-axis currents varies, depending on the required torque and speed.

In our work we are going to investigate and describe a principle allowing efficiency improvement for induction motors: it is the so-called loss-model-based approach, also known as Loss Minimization Controllers (LMCs), which consist of computing losses using the previous series model and selecting a flux level that minimises these losses [1,3,8,9].

A) Loss Model Simplification

From the series iron loss model shown in fig.1, it follows that  $i_{dm}^e, i_{qm}^e$  can be approximated as:

$$i_{dm}^e \approx i_{ds}^e + i_{dr}^e \tag{20}$$

$$i_{qm}^e \approx i_{qs}^e + i_{qr}^e \tag{21}$$

And from equation (1) and (2), we can easily see that the iron loss seems brought to stator and rotor sides, which in the parallel model was presented as a parallel resistance to the magnetizing brunch, this makes the magnetizing voltage components easy to deduce directly from equations (1) and (2):

$$v_{dm}^e = L_M d(i_{ds}^e + i_{dr}^e)/dt - \omega_e L_M (i_{qs}^e + i_{qr}^e) \tag{22}$$

$$v_{qm}^e = L_M d(i_{qs}^e + i_{qr}^e)/dt + \omega_e L_M (i_{ds}^e + i_{dr}^e) \tag{23}$$

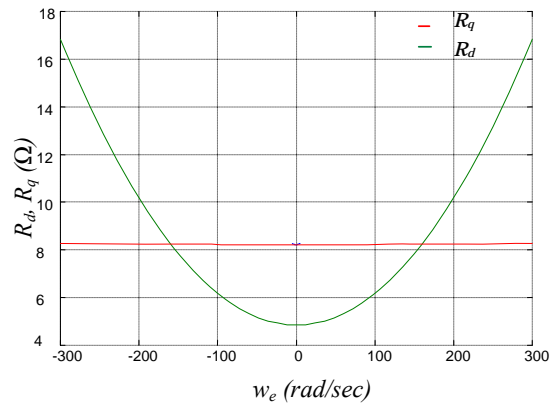

Fig. 3  $R_d(\omega_e)$  and  $R_q(\omega_e)$

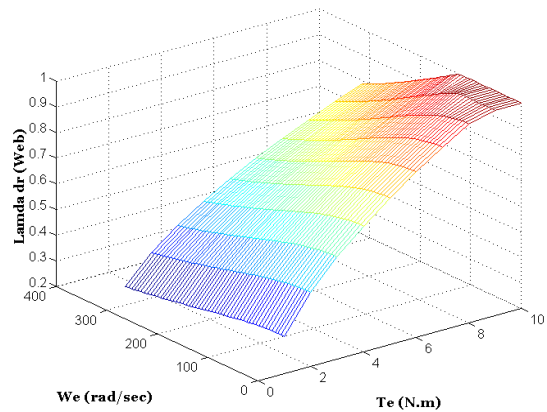

Fig. 4 Optimal flux  $\lambda_{dr}^{e*}$  versus  $\omega_e$  and  $T_e$

Referring to the flux equations (8) and (9) and applying the field orientation principle, we deduce the following:

$$i_{dr}^e = (\lambda_{dr}^e - L_M i_{ds}^e) / L_r \tag{24}$$

$$i_{qr}^e = -L_M i_{qs}^e / L_r \tag{25}$$

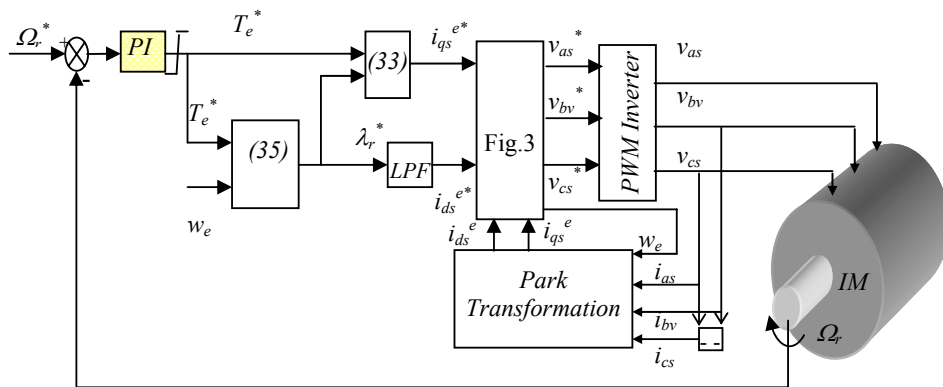

Fig. 5 Configuration system

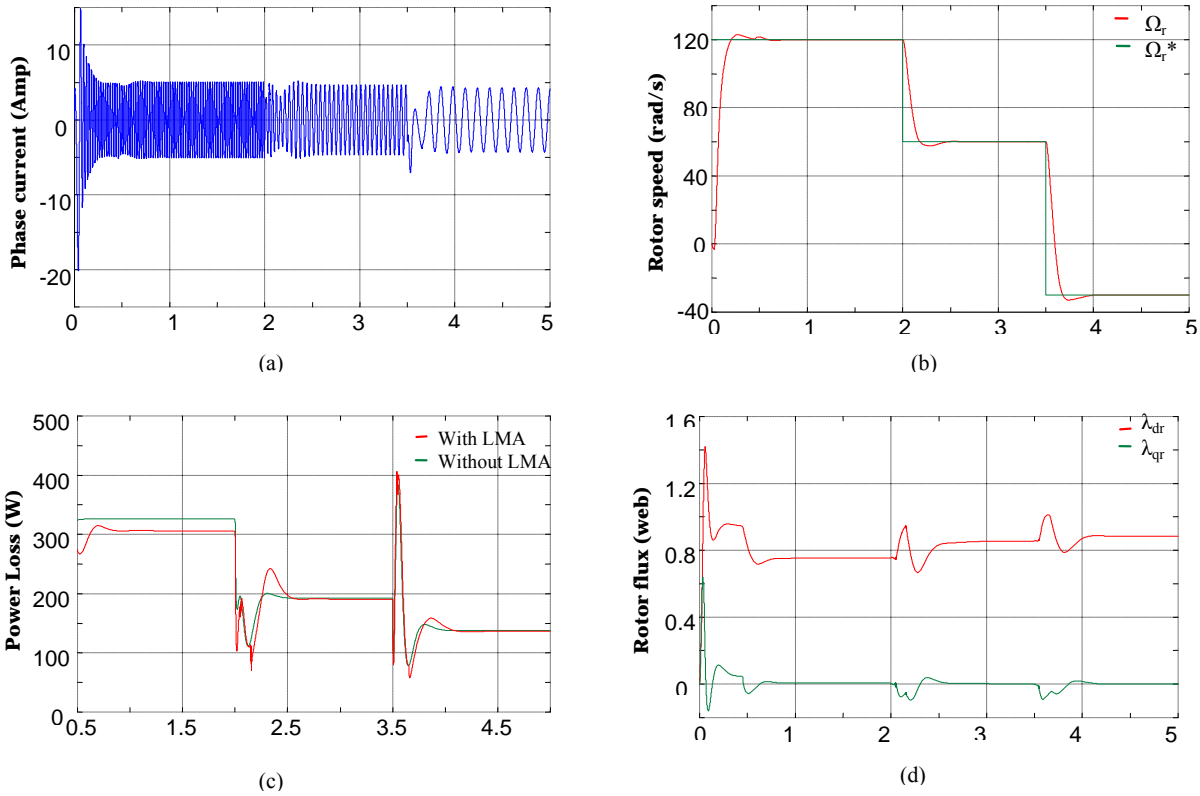

Fig. 6 CaseN°1: load torque=18 Nm,  $\Omega_r = 120$  rad/s at starting,  $\Omega_r = 60$  rad/s at  $t=2$  sec,  $\Omega_r = -30$  rad/s at  $t=3.5$  sec

Substituting into equations (22) and (23):

$$v_{dm}^e = (L_M L_{lr} / L_r) di_{ds}^e / dt + (L_M / L_r) d\lambda_{dr}^e / dt - \omega_e (L_M L_{lr} / L_r) i_{qs}^e \quad (26)$$

$$v_{qm}^e = (L_M L_{lr} / L_r) di_{qs}^e / dt + \omega_e (L_M / L_r) (L_{lr} i_{ds}^e + \lambda_{dr}^e) \quad (27)$$

In the steady state,  $\lambda_{qr}^e = 0$ ,  $d\lambda_{dr}^e / dt = 0$ ,  $i_{dr}^e = 0$ , since  $\lambda_{dr}^e = L_M i_{ds}^e$ .

Therefore, we have:

$$v_{dm}^e = -\omega_e (L_M L_{lr} / L_r) i_{qs}^e \quad (28)$$

$$v_{qm}^e = \omega_e (L_M / L_r) (L_{lr} i_{ds}^e + \lambda_{dr}^e) = \omega_e L_M i_{ds}^e \quad (29)$$

In normal operation slip is low, i.e.  $s \ll 1$ . Therefore, we disregard the iron loss of the rotor, hereafter. Then the iron loss reduces to  $(v_{dm}^{e2} + v_{qm}^{e2}) / R_m$ . along with the copper loss, the total motor losses is:

$$P_{loss} = R_s (i_{ds}^{e2} + i_{qs}^{e2}) + R_r (i_{dr}^{e2} + i_{qr}^{e2}) + (v_{dm}^{e2} + v_{qm}^{e2}) / R_m$$

$$\begin{aligned} &= R_s (i_{ds}^{e2} + i_{qs}^{e2}) + R_r (L_M / L_r)^2 i_{qs}^{e2} + [\omega_e^2 (L_M L_{lr} / L_r)^2 i_{qs}^{e2} \\ &\quad + \omega_e^2 L_M^2 i_{ds}^{e2}] / R_m \\ &= i_{ds}^{e2} [R_s + (\omega_e^2 L_M^2 / R_m)] + i_{qs}^{e2} [R_s + R_r (L_M / L_r)^2 + \omega_e^2 \\ &\quad (L_M L_{lr} / L_r)^2 / R_m] \\ &= R_d (\omega_e) i_{ds}^{e2} + R_q (\omega_e) i_{qs}^{e2} \end{aligned} \quad (30)$$

Where:

$$R_d (\omega_e) = [R_s + (\omega_e^2 L_M^2 / R_m)] \quad (31)$$

$$R_q (\omega_e) = [R_s + R_r (L_M / L_r)^2 + \omega_e^2 (L_M L_{lr} / L_r)^2 / R_m] \quad (32)$$

$R_d (\omega_e)$  and  $R_q (\omega_e)$  are considered to be the d-q axes equivalent resistors representing the total loss and their graphs shown in fig.3 represent their variations with respect to  $\omega_e$ .

Fig. 3 shows that  $R_d$  is dominant over  $R_q$  as  $\omega_e$  increases. Therefore, it motivates us to reduce the d-axis current (or flux level) for the loss minimisation. However, too much decrease in  $i_{ds}^e$  (or  $\lambda_{dr}^e$ ) leads to extremely large  $i_{qs}^e$  for a desired torque production, yielding a large copper loss.

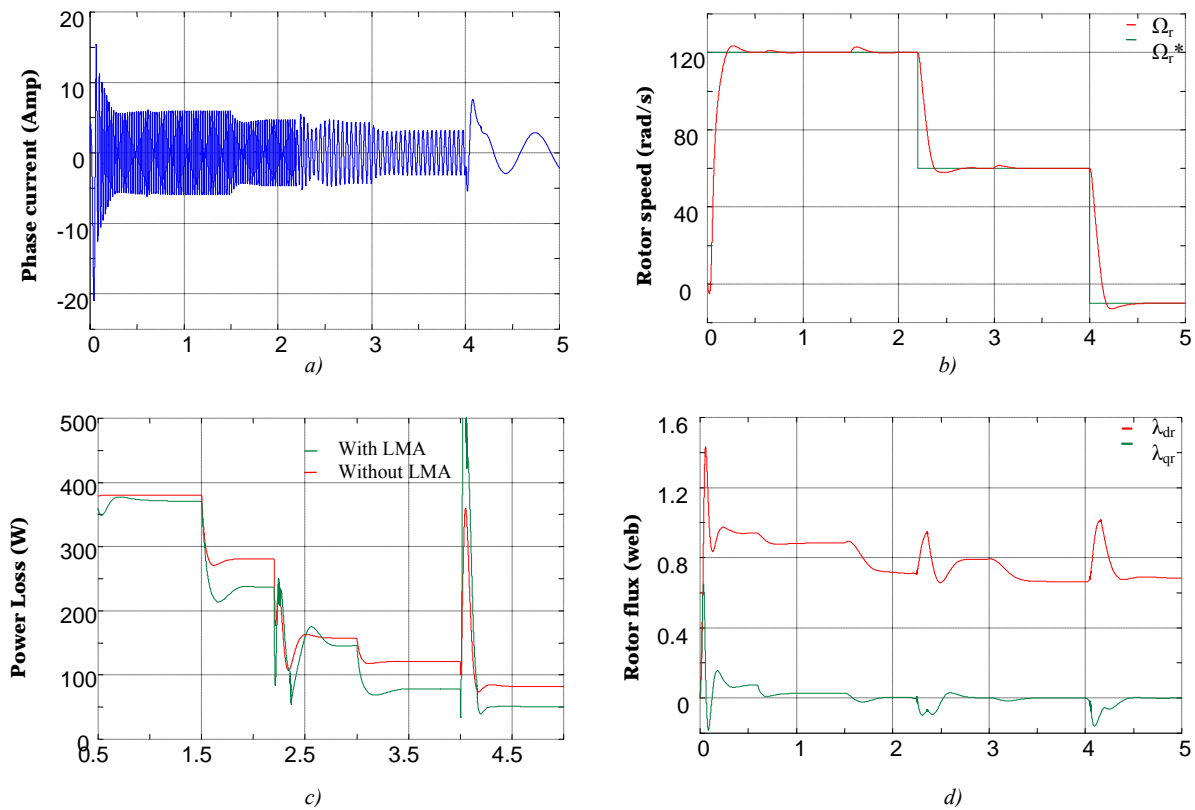

Fig. 7 CaseN<sup>o</sup>3: load torque = 10 Nm at starting, T<sub>l</sub> = 6 Nm at t = 1.5 s, T<sub>l</sub> = 3 Nm at t = 3 s, Ω<sub>r</sub> = 120 rad/s at starting, Ω<sub>r</sub> = 60 rad/s at t = 2.2 s, Ω<sub>r</sub> = -10 rad/s at t = 4 s

Hence, a compromise between iron loss and copper loss needs to be made for optimal operation.

#### B) Optimal Solution for Loss Minimization

The expression of the power loss must be written as function of the developed torque and the rotor flux. To do so, the stator current components,  $i_{ds}^e$  and  $i_{qs}^e$  are replaced in (30) by expressions obtained from the application of the field orientation:

$$i_{qs}^e = (2/3P) (L_r/L_M) T_e / \lambda_{dr}^e \quad (33)$$

$$i_{ds}^e = (1/L_M) \lambda_{dr}^e \quad (34)$$

Therefore the power loss equation in the rotor flux orientation scheme is:

$$P_{loss} = R_d (1/L_M)^2 \lambda_{dr}^{e2} + R_q (2/3P)^2 (L_r/L_M)^2 (T_e / \lambda_{dr}^e)^2 \quad (35)$$

The optimal rotor flux is obtained by, first, taking the partial derivative of the power expression (35) with respect to  $\lambda_{dr}^e$ , second, makes the derivative equals zero and finally, solve for the rotor flux variable:

$$\lambda_{dr}^{e*} = [R_q (2/3P)^2 (L_r/L_M)^2 T_e^2 / (R_d (1/L_M)^2)]^{1/4} \quad (36)$$

Observing the above equation, one can notice that the optimal flux value corresponding to minimum power loss is explicitly dependant of two variables: electromagnetic torque  $T_e$  and the direct and transverse resistances  $R_d$  and  $R_q$ . However, the filed rotating speed  $\omega_e$  is involved. In fact, the transverse resistance is constant whatever the value of  $\omega_e$  whereas the direct one depends directly on the rotating speed.

TABLE I  
INDUCTION MOTOR DATA

Stator resistance	4.85 Ω
Rotor resistance	3.805 Ω
Iron loss resistance	500 Ω
Mutual inductance	0.258 H
Stator inductance	0.274 H
Rotor inductance	0.274 H
Rotor inertia	0.031 Kg.m <sup>2</sup>
Friction coefficient	0.008 Nm.s/trd
Output power	1.5 Kw
Poles	2x2
Voltage	220/380 V
Current	3.64/6.31 A
Rated speed	1420 tr/min
Frequency	50 Hz

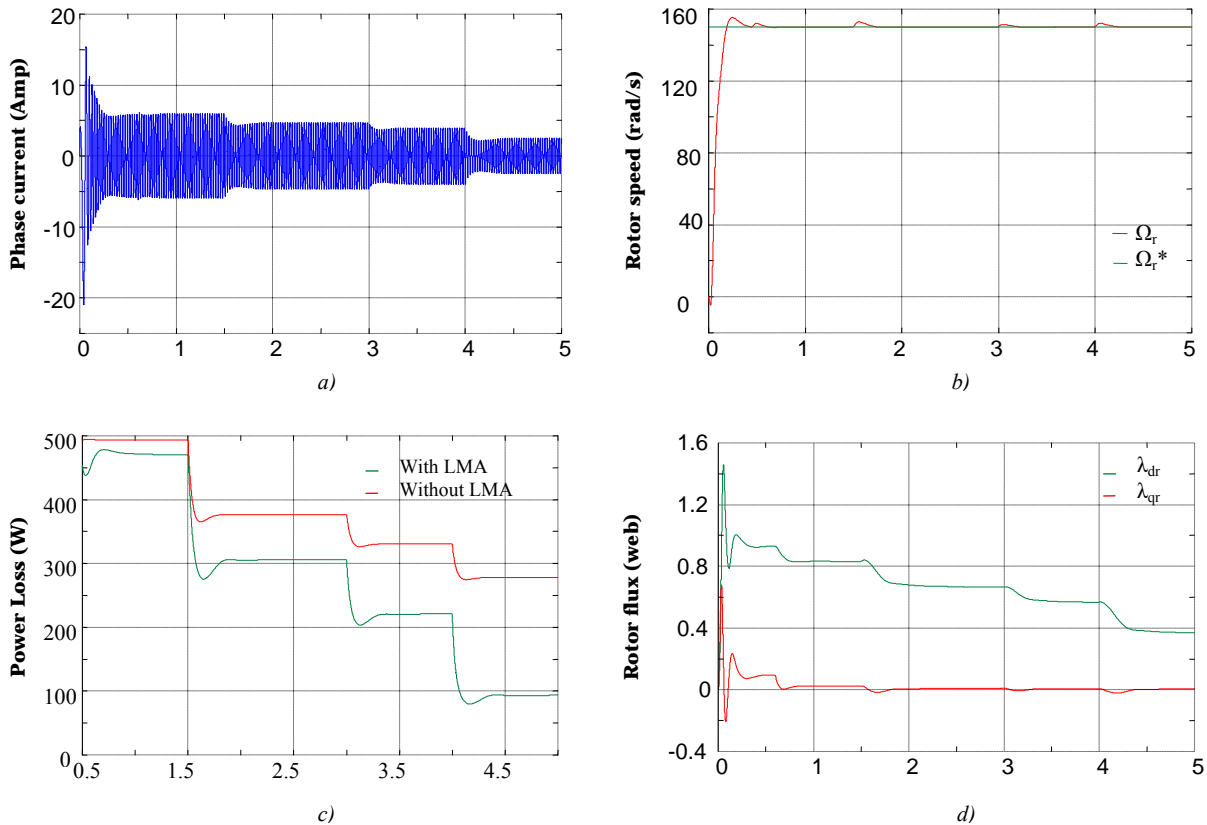

Fig. 8 CaseN°2:  $\Omega_r = 150$  rad/s, load = 10 Nm at starting, load= 6 Nm at  $t= 1.5$  s, load = 4 Nm at  $t= 3$  s, load = 1 Nm at  $t= 4$  s.

Fig. 4 represents the variation of the optimal flux function with respect to these two variables ( $\omega_e$ ,  $T_e$ ) that reflect the operating point.

#### V. DISCUSSION OF SIMULATION RESULTS

A computer program has been developed in MATLAB/SIMULINK software according to the proposed configuration system, Fig. 5. The squirrel cage induction motor whose parameters are shown in Table I should be fed through a PWM inverter. As the present work is focusing on the modeling and the loss minimization, the inverter has been considered as linear gain. In fact, the inverter is a source of loss due to harmonics but this type of loss can not be avoided by flux control. And since the inverter power losses are function of stator current, they will be close to the minimum as the motor is operating near the optimum point. The configuration system contains the modified field oriented controller, Fig. 2 and a bloc which generates the optimal flux using (36) to the FOC block through a low-pass filter. The aim of the LPF is to reduce the torque oscillations due the sudden variation of the optimal rotor flux when a sudden load torque variation is observed. The motor mechanical speed is controlled by a classical PI whose parameters  $K_p$  and  $K_i$  are obtained by using pole placement technique.

To check the effectiveness of the suggested system, several simulations have been performed under different operating conditions, namely:

- Case 1: Constant load torque  $T_l$  with variable rotor speed command  $\Omega_r$ .
- Case 2: Variable load torque  $T_l$  with variable rotor speed command  $\Omega_r$ .
- Case 3: Variable load torque  $T_l$  with constant rotor speed command  $\Omega_r$ .

According to the first case, the obtained results, fig.6, show that for the same driven load the rotor flux is increased (fig.6.d) if the speed decreases and this is justified by the requirement to maintain the torque capability (output power is constant means any decrease in speed must be compensated for by increase in torque that proportional to flux) . At the same time, the modified filed oriented controller keeps the rotor flux orientation well (transverse component is null). The optimum point is reached by the fact that the load torque is maintained equal the rated one and the flux level is increased, whereas the power loss is approximately the same as in the case without LMA. In the second scenario fig.7, the speed is maintained constant but the load is decreased gradually, the less is the load torque the lower is the flux level and hence the minimum is the power loss. It easy

to notice that the decoupling is satisfied since the transverse flux component is not altered by the direct component variation. The third case is a combination of the two previous cases, the motor drive changes its speed and drives variable load torque. Whatever the operating point, the power loss with LMA is less than that obtained without LMA (constant flux operating). In this scenario it's noticed that the overshoot in the flux response is important even though the LMA output is delayed by a LPF. On one hand, the flux oscillations come from the fact the two quantities, load torque and speed, are simultaneously varied within a tight period. On the other hand, the field oriented controller generates the optimal flux on the basis of the knowledge of the torque reference rather than the real load torque. That means to minimize the flux oscillations, a more advanced speed controller may be used, such as the non-linear controller, the sliding mode controller, etc.

## VI. CONCLUSION

Two aspects have been discussed in the paper; the first concerns the rotor field orientation by using the series iron loss modelling, whereas the second is devoted to power loss minimization using the motor model. The advantage comes from using the series model is the elimination of two differential equations describing the magnetizing current in the parallel model. The obtained results show that in difficult situations such that variable flux-variable speed operation, the rotor field orientation is maintained. The association to the modified field oriented controller a mechanism to select the optimal flux leading to minimum power loss (LMA) has not disturbed the decoupling hence the induction motor drive. Furthermore, the LMA needs the value of the electromagnetic torque which its image is generated by the speed controller. As the modified field oriented controller illuminates the detuning due to iron loss between the output electromagnetic torque and the reference torque, therefore the system will be simplified by using the reference torque rather than a torque sensor. As regards the flux and the torque oscillations, the low-pass filter seems not enough to smooth the flux response when a succession of variation in speed reference

and load conditions the motor is exposed to. Consequently, to eliminate completely the flux and torque oscillations, it's suitable to use a Direct Field Orientation Scheme or a non-linear controller with a robust observer to furnish the flux feedback. The observer can be extended to estimate too the stator and rotor resistance as the LMC equation contains their values.

## REFERENCES

- [1] Abrahamsen F., Blaabjerg F., Pederson J. K., Grabowski P. Z. and Thogersen P., 'On the energy optimized control of standard and high efficiency induction motors in CT and HVAC applications', IEEE trans. on industry applications, vol. 34, No 4, July-August 1998
- [2] D.W.Novotny and T.A.Lipo, 'Vector Control and Dynamics of AC Drives', Clarendon Press, Oxford, UK, 1996.
- [3] S. Vaez-Zadeh and F. Hendi, 'A continuous efficiency optimization controller for induction motor drives', Energy Conversion and Management 46 (2005) 701-713
- [4] Wang J.B., Liaw C.M., "Indirect field oriented induction drive with fuzzy detuning correction and efficiency optimization controls", IEE Proc. Electr. Power. Appl., Vol.144 n°.1, January 1997, pp.37-45.
- [5] Sousa G.C.D., Bose B.K., "Fuzzy logic based on-line efficiency optimization control of an indirect vector controlled induction motor drive", IEEE conference record IAS, pp.1168-1174, 15-19 /Nov, 1993, Hawaii, USA.
- [6] Lim S. and Nam K., 'Loss-minimising control scheme for induction motors', IEE Proc.-Electr. Power Appl., Vol. 151, No. 4, pp. 385-397, July 2004
- [7] Nam S. W. and Nasir Uddin M., 'Model-Based Loss Minimization Control of an Induction Motor Drive' IEEE ISIE 2006, July 9-12, 2006, Montreal, Quebec, Canada
- [8] Matsuse K., Yoshizumi T., Katsuta S., Tanigushi S., " High - Response Flux Control of Direct Field Oriented Induction Motor with High Efficiency Tacking Core Loss into Account", IEEE Trans. on Indus. Appl., Vol.35, No. 1, JAN./FEB. 1999, pp.62-69.
- [9] Dal Y. Ohm, 'Dynamic Model of Induction Motors for Vector Control', Drivetech, Inc., Blacksburg, Virginia, 2000.
- [10] Levi E., Boglietti A., and Lazzar M. 'Performance Deterioration in Indirect Vector Controlled Induction Motor Drives due to Iron Losses', IEEE trans. on Indus. Appl., pp. 1312-1318, 1995.
- [11] Jinh w. J., Nam K., 'A Vector Control Scheme for EV Induction Motors with Series Iron Loss Model', IEEE trans. Ind. Electron. Vol. 45, No. 4, pp. 617-624, August 1998.