

# Universal Qibla and Prayer Time Finder

M.Z. Ibrahim and M.Z. Norashikin

**Abstract**—People nowadays love to travel around the world. Regardless of their location and time, they especially Muslims still need to perform their five times prayer. Normally for travelers, they need to bring maps, compass and for Muslim, they even have to bring Qibla pointer when they travel. It is slightly difficult to determine the Qibla direction and to know the time for each prayer. In this paper we present a new electronic device called Universal Qibla and Prayer Time Finder to locate the Qibla direction and to determine each prayer time based on the current user's location. This device use PIC microcontroller equipped with digital compass and Global Positioning System (GPS) where it will display the exact Qibla direction and prayer time automatically at any place in the world. This device is reliable, user friendly and accurate in determining the Qibla direction and prayer time.

**Keywords**—Digital compass, embedded system, global position system, prayer time, qibla.

## I. INTRODUCTION

FOR centuries, Muslims all over the world face Mecca (towards Qibla or Kaaba) and perform prayer, five times a day. It is hard to determine the Qibla direction and know the prayer of each prayer time. In the old days, people use stick and sees it shadow to know the prayer times and Qibla direction. Nowadays, researches and findings in astronomical help much in computing the prayer time and direction of Qibla automated. There are certain applications in the website that are available to the user to know the Qibla direction and prayer times. They have to insert information on current location and the Qibla and prayer information will be given. As the technologies grow, various mobiles company gives prayer time and Qibla direction services. The problem is that the application itself is not portable and self generated rely on the service itself. Services from websites need the user to have internet connections making it not practical for daily use.

People commute everyday, moving from one place to another place and they need to know the prayer time and Qibla direction in the current place they go. There are devices

like 'Travelers Watch' and 'Qibla Finder' that can help travelers by showing time and direction according to the latitude and longitude. The problem is these application applications do not come from single device. To determine the Qibla and prayer time the user needs two difference devices. Some peoples uses list or calendar to know the prayer time and manual compass to know the direction of Qibla. This method is quite troublesome to travelers since the person has to know the latitude and longitude of the current location.

We have developed a new electronic device called Universal Qibla and Prayer Time Finder to locate the Qibla direction and to determine each prayer time based on the current user's location. This device is equipped with digital compass and Global Positioning System (GPS) where it will display the exact Qibla direction and prayer time automatically at any place in the world.

Universal Qibla and Prayer Time Finder designed by modules. It consists of hardware and software parts. Using a modular approach, parts are easier to implement and troubleshooting can be done easily. Fig. 1 shows the architecture of this device. It divided into three parts which are input, microcontroller and output. The input parts consist of digital compass and GPS. Digital compass provide the direction in degree from Magnetic North and GPS provide the latitude, longitude, date and time. The output part consists of LCD which displays the information such as prayer time, qibla direction and GPS information.

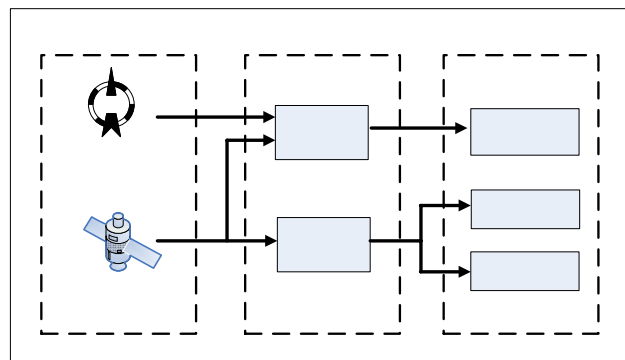

Fig. 1 Architecture of Universal Qibla and Prayer Time Finder

This paper organized as follows: Section 2 describes the prayer time and qibla algorithm in details. Section 3 and section 4 describes the hardware and software development. Section 5 described the results and discussion and followed by conclusion in Section 6.

M.Z. Ibrahim is with the Faculty of Electrical and Electronics Engineering, Universiti Malaysia Pahang, 25000 Kuantan, Pahang, Malaysia (e-mail: zamri@ump.edu.my).

M.Z. Norashikin is with the Faculty of Chemical and Natural Resources Engineering, Universiti Malaysia Pahang, 25000 Kuantan, Pahang, Malaysia (e-mail: shikin@ump.edu.my).

This work has been supported by Universiti Malaysia Pahang Short Grant Project under vot number RDU 070360.

## II. ALGORITHM

## A. Prayer Time

The Muslims are obligatory to perform their prayers five times daily. The allowable period of time for performing each prayer will start from one prayer time to another. Basically, the prayer times can be broken down into [1], [2]:

- 1) **FAJR**: Starts with the dawn or morning twilight. Fajr ends just before sunrise.
- 2) **ZUHR**: Begins after midday when the trailing limb of the sun has passed the meridian. For convenience, many published prayer timetables add five minutes to mid-day (Zawal) to obtain the start of Zuhr. Zuhr ends at the start of Asr time.
- 3) **ASR**: The timing of ASR depends on the length of the shadow cast by an object. According to the Shafi school of jurisprudence, Asr begins when the length of the shadow of an object exceeds the length of the object. According to the Hanafi School of jurisprudence, Asr begins when the length of the shadow exceeds twice the length of the object. In both cases, the minimum length of shadow (which occurs when the sun passes the meridian) is subtracted from the length of the shadow before comparing it with the length of the object.
- 4) **MAGHRIB**: Begins at sunset and ends at the start of Isha.
- 5) **ISHA**: Starts after dusk when the evening twilight disappears.

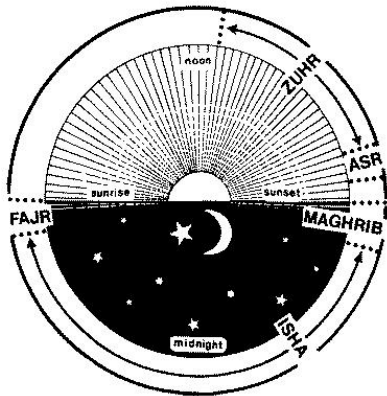

Fig. 2 Period for each prayer time

The prayer times for a certain place are basically different from another. In order to calculate the prayer times, the information on the latitude and longitude of that location as well as its reference longitude must be obtained. It can be calculated using mathematical formulation [1], [3]-[5].

$$Z = 12 + \frac{R-L}{15} + \frac{T}{60} \quad (1)$$

$$U = \frac{1}{15} \cdot \arccos\left(\frac{\sin(-0.8333 - 0.0347(H)^{0.5}) - \sin D \cdot \sin B}{\cos D \cdot \cos B}\right) \quad (2)$$

$$V = \frac{1}{15} \arccos\left(\frac{-\sin G - \sin D \cdot \sin B}{\cos D \cdot \cos B}\right) \quad (3)$$

$$W = \frac{1}{15} \cdot \arccos\left(\frac{\sin(\arccot(1 + \tan(B-D))) - \sin D \cdot \sin B}{\cos D \cdot \cos B}\right) \quad (4)$$

$$X = \frac{1}{15} \cdot \arccos\left(\frac{\sin(\arccot(2 + \tan(B-D))) - \sin D \cdot \sin B}{\cos D \cdot \cos B}\right) \quad (5)$$

where

- $B$  = Latitude of place
- $L$  = Longitude of place
- $R$  = Reference longitude (TIME BAND x 15)
- $H$  = Height above sea level in meters
- $D$  = Declination angle of sun
- $T$  = Equation of time
- $G$  = Twilight angle

and

- Fajr =  $Z-V$
- Sunrise =  $Z-U$
- Zuhr =  $Z$
- Asr1 (Shafi) =  $Z+W$
- Asr2 (Hanafi) =  $Z+X$
- Maghrib/Sunset =  $Z+U$
- Isha =  $Z+V$

## B. Qibla direction

Kaaba is a reference point for all Muslim around the world during their prayer. The qibla is the direction such that when a human observer faces it, it is as if he is looking at the diameter of the earth passing through the kaaba. Kaaba is located at (21.42330 degree north, 39,8230 degree east) in Mecca city in the country of Saudi Arabia. Muslim people around the world must face their chest to Kaaba every time they do their prayer for at least five times a day.

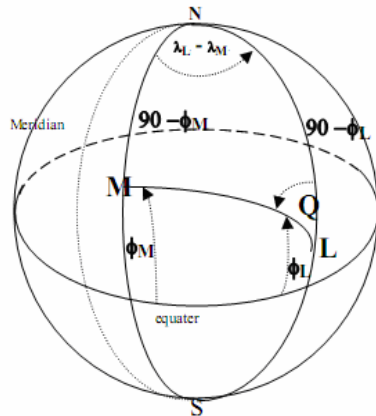

Fig. 3 Qibla direction (Q)

A simple formulation in spherical trigonometry [3], [7] can be used in solving the problem of qibla determination. Fig. 3 shows geometrical situation for determination of direction between two geographical places. Equation (6) is used in determination of qibla direction (Q) counts from north to west. When N is Geographical North Pole, NS is any meridian; M is Mecca city and L is any place.

$$\tan Q = \frac{\sin(\lambda_L - \lambda_M)}{\cos(\varphi_L) \cdot \tan(\varphi_M) - \sin(\varphi_L) \cdot \cos(\lambda_L - \lambda_M)} \quad (6)$$

where

$$\lambda_M = \text{Mecca longitude} = 39.8230^\circ \text{E}$$

$$\lambda_L = \text{any Longitude of a place}$$

$$\varphi_M = \text{Mecca latitude} = 21.42330^\circ \text{N}$$

$$\varphi_L = \text{any latitude of a place}$$

### III. HARDWARE

#### A. Microcontroller

PIC is a family of Harvard architecture microcontrollers made by Microchip Technology. The name PIC initially referred to "Programmable Interface Controller", but shortly thereafter was renamed "Programmable Intelligent Computer". PICs are popular with developers and hobbyists alike due to their low cost, wide availability, large user base, extensive collection of application notes, availability of low cost or free development tools, serial programming and re-programming with flash memory capability.

During the initial development, PIC 18F452 was used as microcontroller, but due to its limitation on memory size and big size (40 pins), we change to PIC 18F2620 which have 4 times bigger memory and smaller size (28 pins) compared to PIC 18F452. This microprocessor as shown in Fig.4 has high computational performance at an economical price with the

addition of high-endurance, Enhanced Flash program memory. All of these features make these microcontrollers a logical choice for many high-performances, power sensitive applications.

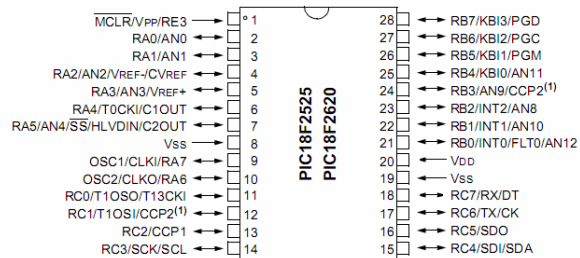

Fig. 4 Microchip PIC 18F2620 pin diagram

#### B. Digital Compass

A compass is a navigational instrument for determining direction relative to the earth's magnetic poles. A typical compass which can be found easily in any shops is not suitable because it is not automated and unable to communicate between electronic devices. The Honeywell HMC6352 is a fully integrated electronic compass module that combines 2-axis magneto-resistive sensors with the required analog and digital support circuits, and algorithms for heading computation.

The HMC6352 provides a user calibration routine with the 'C' command permitting entry into the calibration mode and the 'E' command to exit the calibration mode. Once in calibration mode, the user is requested to rotate the compass on a flat surface at least one full circular rotation while the HMC6352 collects several readings per second at various headings with the emphasis on rotation smoothness to gather uniformly spaced readings. Optimally two rotations over 20 seconds duration would provide an accurate calibration.

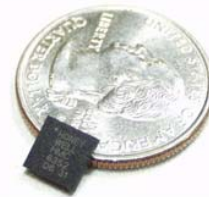

Fig. 5 Honeywell HMC6352

#### C. Global Positioning System (GPS)

The Global Positioning System (GPS) is a Global Navigation Satellite System (GNSS) developed by the United States Department of Defense. It is the only fully functional GNSS in the world. It uses a constellation of between 24 and 32 Medium Earth Orbit satellites that transmit precise microwave signals, which enable GPS receivers to determine their current location, the time, and their velocity.

GPS Module EB-85A from Etek Navigation Inc as shown

in Fig. 6 was used as GPS receiver. This module is the best candidate for our system based on the performance, sensitivity, power consumption and size. EB-85A has excellent start-up times, position accuracy, update rate up to 5 Hz and the sensitivity of -158dbm. The active antenna on board helps the system integrators to do the design-in easily.



Fig. 6 EB-85A GPS receiver

#### D. Liquid Crystal Display (LCD)

A LCD is an electro-optical amplitude modulator realized as a thin, flat display device made up of any number of color or monochrome pixels arrayed in front of a light source (backlight) or reflector. It is often utilized in battery-powered electronic devices because it uses very small amounts of electric power. Fig.7 shows the LCD display which is used to display the information such as prayer time, qibla direction and GPS.



Fig. 7 16x2 Character LCD

#### IV. SOFTWARE

PIC microcontroller is a special-purpose integrated circuit designed to perform one or a few dedicated function depending on code integrated inside it. It is usually embedded as part of a complete device including hardware and mechanical parts. The code is writing using programming language such as c or basic that provides a structured mechanism for defining pieces of data, and the operations or transformations that to be carried by microcontroller.

CCS C Compiler which has been developed exclusively for the PIC microcontroller has a generous library of built-in functions, preprocessor commands, and ready-to-run example programs to quickly jump-start any project. It has Microsoft Window based Integrated Development Environment (IDE) compiler that capable to aid in program design and editing. Features of the IDE include a color syntax editor, a powerful C Aware Real-time Debugger, RTOS, linker, and a New Project Wizard for peripherals and drivers.

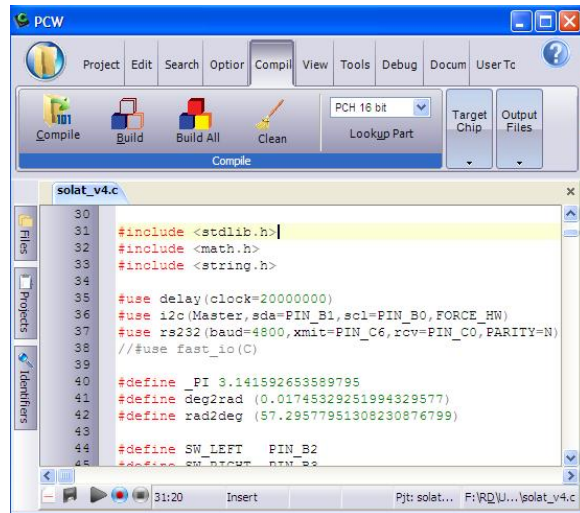

Fig. 8 CCS C Compiler IDE

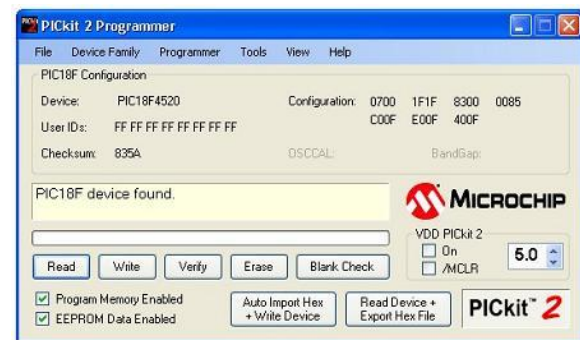

Fig. 9 PICKit 2 Programmer Software

The PICKit 2 Programmer is a Windows PC application that provides a simplified, feature rich interface for PICKit 2 device. It will transfer the code to PIC microcontroller through PICKit 2 device.

#### V. RESULTS

This section discusses the result obtained. There are five functions that can be applied on the device which are:

- 1) Prayer time (Fajr, Zuhr, Asr, Maghrib and Isha)
- 2) Qibla direction
- 3) North direction
- 4) Compass calibration
- 5) GPS information (time, date, latitude, longitude, signal validity and satellite number)

Fig. 10 shows the Asr prayer time. There are five prayer times that can be display on this screen. The prayer time will change accordingly to latitude and longitude set by GPS. Fig. 11 shows the local time and date information in real-time system which is provided by GPS.



Fig. 10 Asr prayer time



Fig. 13 Satellite tracking



Fig. 11 Time and date information from GPS

Fig. 12 shows the latitude and longitude where the device is place. The latitude and longitude information is very important in order to calculate the prayer times and qibla direction accurately. Fig. 13 shows the signal validity and number of satellite communicate with GPS receiver. In Malaysia, normally it takes about 1 to 3 minutes to get a valid signal.



Fig. 12 Latitude and longitude information from GPS

Qibla direction is calculated based on earth coordinate and north direction. User is requested to rotate the compass until the screen display 'arrow' as shown in Fig. 14. Hard-iron effects are due to magnetized materials nearby the digital compass can reduce the accuracy of heading. This device has special calibration routine that collects surrounding magnetic field readings to correct hard-iron distortions. An example would be the microcontroller or GPS in which the compass is mounted onto. Upon exiting the calibration mode, the resulting magnetometer offsets and scaling factors are updated.



Fig. 14 Qibla direction

## VI. CONCLUSION

In this paper "Universal Qibla and Prayer Time Finder" has been presented to determine prayer times and the qibla direction using embedded system. The GPS receiver provides information of the latitude, longitude, date and time and this information will be synchronized with digital compass in order for the whole system to operate correctly.

This device integrates several features and functions that make it prominent from others. In most products, determination of prayer time and locating the direction of Qibla will be based on the location of the nearest city or district inside the database. But, these products might not have the ability to provide users with the actual prayer time and qibla direction. Using a GPS receiver, the locations of the

users can always been updated automatically and not the conventional way where the users need to select the city and the current location manually. The digital compass in this system will be pointed to Kaaba automatically in real time system as compared to conventional way where the user aligned them self using sun as reference.

This system is reliable, user friendly and could be used in other vehicles such as train, ship, and airplane and also on the ground. The Muslim population for the year 2007 is about 1.6 billion which represent a 27% of the world population [8]. Therefore, it is highly believe that the opportunity to commercialize this project is huge.

#### REFERENCES

- [1] Hajewaming Niweateh, *Al Falak*, Islamic Academy, Bangkok, Thailand, 2002.
- [2] Susikman Azhari, *Ilmu Falak*, Lazuardi, Yogyakarta, Indonesia, 2001.
- [3] Mohammad Ilyas, *A Modern Guide to Astronomical Calculations of Islamic Calendar, Times & Qibla*, Berita Publishing Sdn Bhd., Kuala Lumpur, Malaysia, 1984.
- [4] Jason John Nassau, *Practical Astronomy*, Mc-Graw-Hill Book Company, New York, 1984.
- [5] Jean Meeus, *Astronomical Algorithms*, Willmann -Bell Inc, Richmond, USA, 1991.
- [6] Moulana Yakub Qasmi and Tariq Muneer, *Prayer Times for United Kingdom & Ireland*, Islamic Research Institute of Britain, Dewsbury, UK, 1989.
- [7] Bagvi and Malik Bashir Ahmed, *Determination of the Direction of Qibla and the Islamic Timings*, Ashrafal-Madaris, Karachi, 1970.
- [8] [www.islamicpopulation.com](http://www.islamicpopulation.com), February 2007.