

Ultrasonic System for Diagnosis of Functional Gastrointestinal Disorders: Development, Verification and Clinical Trials

Eun-Geun Kim, Won-Pil Park, Dae-Gon Woo, Chang-Yong Ko, Yong-Heum Lee, Dohyung Lim,
Tae-Min Shin, Han-Sung Kim, and Gyoung-Jung Lee

Abstract—Functional gastrointestinal disorders affect millions of people spread all age regardless of race and sex. There are, however, rare diagnostic methods for the functional gastrointestinal disorders because functional disorders show no evidence of organic and physical causes. Our research group identified recently that the gastrointestinal tract well in the patients with the functional gastrointestinal disorders becomes more rigid than healthy people when palpating the abdominal regions overlaying the gastrointestinal tract. Aim of this study is, therefore, to develop a diagnostic system for the functional gastrointestinal disorders based on ultrasound technique, which can quantify the characteristic above related to the rigidity of the gastrointestinal tract well.

Ultrasound system was designed. The system consisted of transmitter, ultrasonic transducer, receiver, TGC, and CPLD, and verified via a phantom test. For the phantom test, ten soft-tissue specimens were harvested from porcine. Five of them were then treated chemically to mimic a rigid condition of gastrointestinal tract well, which was induced by functional gastrointestinal disorders. Additionally, the specimens were tested mechanically to identify if the mimic was reasonable. The customized ultrasound system was finally

verified through application to human subjects with/without functional gastrointestinal disorders (Normal and Patient Groups).

It was identified from the mechanical test that the chemically treated specimens were more rigid than normal specimen. This finding was favorably compared with the result obtained from the phantom test. The phantom test also showed that ultrasound system well described the specimen geometric characteristics and detected an alteration in the specimens. The maximum amplitude of the ultrasonic reflective signal in the rigid specimens (0.2 ± 0.1 Vp-p) at the interface between the fat and muscle layers was explicitly higher than that in the normal specimens (0.1 ± 0.0 Vp-p). Clinical tests using our customized ultrasound system for human subject showed that the maximum amplitudes of the ultrasonic reflective signals near to the gastrointestinal tract well for the patient group (2.6 ± 0.3 Vp-p) were generally higher than those in normal group (0.1 ± 0.2 Vp-p). Here, maximum reflective signals was appeared at 20mm depth approximately from abdominal skin for all human subjects, corresponding to the location of the boundary layer close to gastrointestinal tract well. These results suggest that newly designed diagnostic system based on ultrasound technique may diagnose enough the functional gastrointestinal disorders.

Manuscript received November 30, 2006. This research was supported by Regional Research Center Program which was conducted by the Ministry of Commerce, Industry and Energy of the Korean Government.

Eun Geun Kim is with Department of Biomedical Engineering, Yonsei University, Wonju, Korea (phone: +82-33-760-2805; fax: +82-33-760-2805; e-mail: kimeg917@gmail.com).

Won Pil Park is with Department of Biomedical Engineering, Yonsei University, Wonju, Korea (phone: +82-33-760-2913; fax: +82-33-760-2913; e-mail: pwpil@cabe.yonsei.ac.kr).

Dae Gon Woo is with Department of Biomedical Engineering, Yonsei University, Wonju, Korea (phone: +82-33-760-2913; fax: +82-33-760-2913; E-mail: dragon1180@yonsei.ac.kr).

Chang Yong Ko is with Department of Biomedical Engineering, Yonsei University, Wonju, Korea (phone: +82-33-760-2913; fax: +82-33-760-2913; e-mail: cyko@cabe.yonsei.ac.kr).

Dohyung Lim is with Institute of Medical Engineering, Yonsei University, Wonju, Korea (phone: +82-33-760-2913; fax: +82-33-760-2913; e-mail: pwpil@cabe.yonsei.ac.kr).

Yong Heum Lee is with Institute of Medical Engineering, Yonsei University, Wonju, Korea (phone: +82-33-760-2805; fax: +82-33-760-2805; e-mail: koaim@yonsei.ac.kr).

Tae Min Shin is with Institute of Medical Engineering, Yonsei University, Wonju, Korea (phone: +82-33-760-2805; fax: +82-33-760-2805; e-mail: tmshin@yonsei.ac.kr).

Han Sung Kim is with Institute of Medical Engineering, Yonsei University, Wonju, Korea (phone: +82-33-760-2913; fax: +82-33-760-2913; e-mail: hanskim@yonsei.ac.kr).

Gyoung Jung Lee is with Department of Biomedical Engineering, Yonsei University, Wonju, Korea (corresponding author to provide phone: +82-33-760-2805; fax: +82-33-760-2805; e-mail: fa1472@gmail.com).

Keywords—Functional Gastrointestinal Disorders, Diagnostic System, Phantom Test, Ultrasound System.

I. INTRODUCTION

FUNCTIONAL gastrointestinal disorders currently affect millions of people spread all age regardless of race and sex [1]. This functional gastrointestinal disorders, including the irritable bowel syndrome and functional dyspepsia, are characterized by chronic symptoms referable to the gastrointestinal tract in the absence of a currently recognized biochemical or structural explanation [2, 3].

Functional disorders refers primarily to an alerted physiological function rather than an identifiable structural or biochemical cause in the way of the body works [1]. This fact means that the functional disorder does not show any evidence of an organic or physical disease [1]. The functional gastrointestinal disorders can not be, therefore, diagnosed in traditional way; that is, as an inflammatory, infectious, or structural abnormality that can be seen by commonly used examination, x-ray or laboratory test (i.e., blood test). This may lead to misdiagnosis and misguided treatment. The method for the accurate diagnosis of the functional gastrointestinal disorders is, therefore, necessarily developed.

Ultrasound, a form of mechanical energy that is transmitted through and into biological tissues as an acoustic pressure wave, is used widely in medicine as a therapeutic, operative, and diagnostic tool [4]. Therapeutic ultrasound uses intensities as high as 1 to 3W/cm² and can cause considerable heating in living tissues to reduce pain and muscle spasms, and to improve muscle mobility. The ultrasound as a surgical instrument uses higher levels of intensity of 5 to 300W/cm² to fragment calculi, to initiate the healing of non-unions, to ablate diseased tissues such as cataracts. Diagnostic ultrasound use much lower magnitudes of 1 to 50mW/cm² to image non-invasively vital organs, fetal development, peripheral blood flow, and metabolic bone diseases and, coincidentally, to evaluate fracture callus during healing. The intensity level used for imaging is regarded as non-thermal and non-destructive [5]. At the present time, various therapeutic, operative, and diagnostic methods using ultrasound characteristics have been still developing, and their effectiveness have been identifying in practical clinics. These facts indicate that ultrasound technique may be challengeable in the development of the accurate diagnostic system for the functional gastrointestinal disorders.

Our research group identified recently that the gastrointestinal tract well in patients with the functional gastrointestinal disorders becomes more rigid than that in healthy people when palpating the abdominal regions overlaying the gastrointestinal tract well. Objective of current study is, therefore, to develop a diagnostic system for the functional gastrointestinal disorders based on ultrasound technique, which can quantify the characteristic above related to the rigidity of the gastrointestinal tract well.

II. SYSTEM DESIGN

Ultrasound system was designed to detect a degree of rigidity of gastrointestinal tract (Fig. 1). The rigidity was determined analyzing amplitude of reflective signals of ultrasound. The system consisted of following main elements: transducer, transmitter, low-noise amplifier (LNA), band-pass filter (BPF), time gain compensator (TGC) and complex programmable logic device (CPLD) for control of the system.

Transducer was designed capable of minimizing diffraction and maximizing conventional focus of ultrasound. The transducer had a diameter of 12 mm and a central frequency of 4.93MHz. The -6dB pulse-echo (two-way) bandwidth of the transducer was about 47% of the central frequency. The transducer was made of PZT ceramic/polymer composite material and was sandwiched between a front matching layer and a low-impedance absorbing backing layer. The transmitter excited the transducer to emit a short pulse of about 100ns pulse duration and 1ms pulse repetition period. The excitation pulse amplitude was of the order of 12V.

Echo signals immediately after the transmission were received and filtered through the BPF, which was 4th order band pass filter to meet the, high (5.1MHz) and low (4.9MHz) frequency cut-offs and 5MHz center frequency. The filtered signals were then amplified by the LNA and TGC block.

The optimum dynamic performance of the system was achieved by using a LNA. It provided the necessary input

impedance. Then, the LNA provided a low-noise fixed gain, whereas the TGC function allowed the gain to be increased with time to compensate the increased attenuation of the signal.

The block diagram of the digitally controlled TGC is shown in Fig. 2. It was based on a specialized low-noise, voltage controllable amplifier AD603, an 8bit digital-to-analog converter, and a high-density CPLD. Voltage controllable amplifier AD603 provided an accurate and pin-selectable gain of 40dB and 90MHz bandwidth and low input noise spectral density of 1.3nV Hz^{-1/2}. The gain was, then, calibrated to be linear in decibels. The 8-bit data, generated by the CPLD, determined short pulse duration (100ns) and the actual slope profile of the gain compensation. The CPLD provided advanced in-system programming capabilities and permitted user selection of pre-determined slope profiles.

We determined the TGC slope using phantom experiment; as a result, echo signals which returned from phantom had same amplitude at the same medium. The phantom test will be described in detail at following section. The amplified signal then was filtered to improve its signal-to-noise ratio and passed to the 100MHz high-speed digitizer (by National Instrument) to perform the analog-digital conversion. The digitizing machine was a PC-based machine with a single 3GHz CPU and provided echo data in real time. Data transfer, processing, and display were achieved using a monitoring program developed by Labview 7.1 (National Instruments, Austin, Texas, USA).

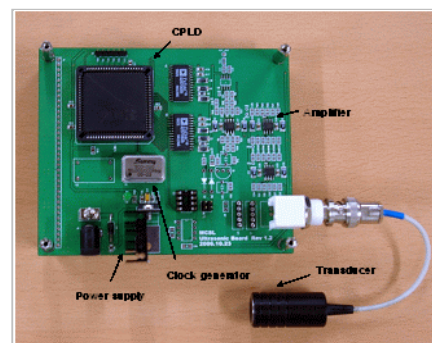

Fig. 1 Ultrasound system for diagnosis of functional gastrointestinal disorders and its elements

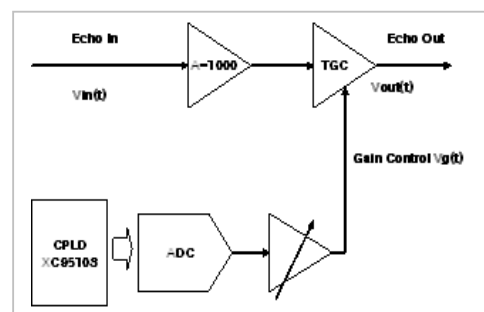

Fig. 2 The block diagram of a digitally controlled TGC (time-gain compensator) for the diagnosis system

III. VERIFICATION OF CUSTOMIZED ULTRASOUND SYSTEM

First, the specimens were tested mechanically whether or not the specimens were well treated chemically for representation of the rigid condition of them, which can be induced by the functional gastrointestinal disorders. Second, the customized ultrasound system was verified via 1) quantitative analysis of the reflective characteristics of the ultrasound signals applied to the specimens and 2) comparison of the thickness of each tissue layer computed inversely from the ultrasonic reflective signals with that measured from the actual specimens.

A. Specimen Preparation

Ten soft-tissue specimens were harvested from porcine. Five of them were then treated chemically to mimic a rigid condition of gastrointestinal tract well, which was induced by the functional gastrointestinal disorders. A chemical liquid was injected to the interface between the fat and muscle layers to mimic the rigid condition. This chemical treatment made it possible to harden a region of the muscle layer in the specimens. The specimens consisted of three soft-tissue layers making up the overall object, skin, fat and muscle, going from top to bottom (Fig. 3). Dimension of the specimens was 20 × 20 × 21 mm approximately.

B. Compression Test and Analysis

In-vitro compressive test using Instron Microtest System (5848 series, Instron, Norwood, MA, USA) was performed for all specimens (Fig. 3). It was performed to identify whether or not the specimens were well treated chemically for representation of the rigid condition of them. The compressive loads corresponded to $0.01s^{-1}$ strain rate were applied continuously to the specimens. Pre-cycling was then applied three times just before the compression test, to adjust specimen location and reduce viscoelastic characteristics. Non-linear hyperelastic material model (*First Order Ogden Model*) was used to describe mechanical characteristics for the normal and rigid conditions. The hyperelastic material model was based on the following strain energy function U :

$$U = \frac{2\mu_1}{\alpha_1^2} (\bar{\lambda}_1^{\alpha_1} + \bar{\lambda}_2^{\alpha_1} + \bar{\lambda}_3^{\alpha_1} - 3) + \frac{1}{D} (J^{el} - 1)^2 \quad (3)$$

U : strain energy per unit of reference volume,
 μ_1 and α_1 : temperature-dependent material parameters,
 J^{el} : elastic volume ratio,
 $\bar{\lambda}_i = J^{-1/3} \lambda_i$: deviatoric stretches, and
 λ_i : principal stretches.

For statistical analysis, a paired student's t-test was used to identify a significant difference between the results obtained from the normal and rigid conditions of the specimens, for the *compression test*. The significance level was then set at 0.05.

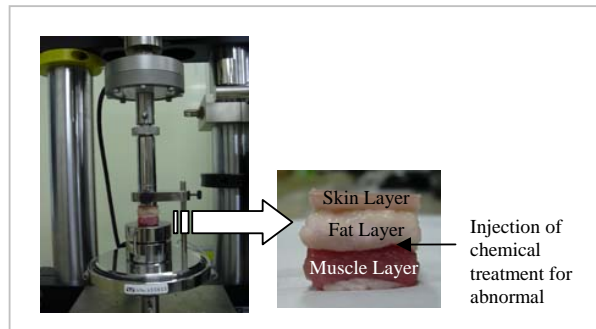

Fig. 3 Instron Microtest System (left) and Specimen (right): a chemical treatment was injected into the interface between the fat and muscle layers of the specimens, to mimic a rigidity of the gastrointestinal tract well

Fig. 4 showed stress-strain curves drawn from the hyperelastic material model (*First Order Ogden Model*) determined from the compressive tests. It was identified that the rigid specimens (μ_1 : 1.1 ± 0.2 MPa and α_1 : 18.5 ± 2.4) were generally more rigid than the normal specimens (μ_1 : 0.5 ± 0.3 MPa and α_1 : 19.5 ± 1.9) ($p < 0.05$). Here, there was no significant difference between α_1 values determined for the normal and abnormal groups ($p > 0.05$). This finding indicates that the specimens treated to represent the rigid conditions were reliable.

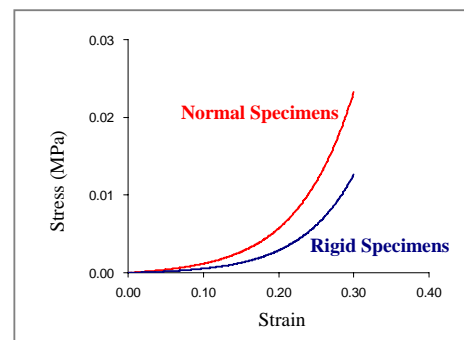

Fig. 4 Stress-Strain curves drawn from the hyperelastic material model determined from the compressive tests; the hyperelastic material model was used for presentation of non-linear mechanical characteristic of the specimens

C. Phantom Test and Analysis

It was proved that the customized ultrasound system was reliable to detect the alteration of the rigidity in the muscle layer. Fig. 5 showed a representative change in the ultrasonic reflective signals corresponding to the alteration of the rigidity in the muscle layer. Here, a paired student's t-test was used to identify a significant difference between the ultrasonic reflective signals determined for the normal and rigid specimens. The significance level was then set at 0.05.

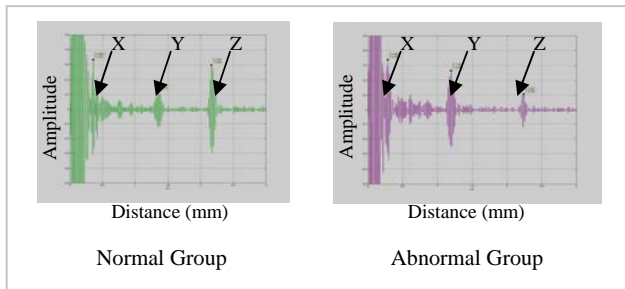

Fig. 5 A representative ultrasonic response obtained from the normal (left) and rigid (right) specimens. X, Y, and Z indicate ultrasonic response at the interface between the skin and fat layers, the fat and muscle layers, and the muscle layer and the ground where the specimen is attached, respectively

The maximum amplitudes of the reflective signal at the interface between the skin and fat layers for the normal specimens (0.23 ± 0.05) were similar to that for the abnormal group (0.33 ± 0.12) ($p > 0.05$). The amplitudes at the interface between the fat and muscle layers for the normal group (0.09 ± 0.03) were higher than that for the abnormal group (0.19 ± 0.07) ($p < 0.05$). The maximum amplitudes of the ultrasonic reflective signals at the interface between the fat and muscle layers were decreased $62.4 \pm 10.9\%$ (normal specimens) and $36.9 \pm 27.7\%$ (rigid specimens) relative to that at the interface between the skin and fat layers. The alteration of the maximum amplitudes of the ultrasonic reflective signals, which were induced by a change of the rigidity, was average 25.5% between the normal and rigid specimens. Here, there was a significant difference between the results obtained from the normal and rigid specimens ($p < 0.05$). These findings were favorably corresponded to the increase of the rigidity in the muscle layer. The decrease of the maximum amplitudes at the interface between the muscle layer and the ground, relative to the increase of the amplitude at the interface between the fat and muscle layers, was favorably in agreement with the general concept of the ultrasonic reflective signal [6]. Additionally, the thickness of each tissue layer (Skin: 2.8 ± 0.5 , Fat: 12.5 ± 2.3 , Muscle: 8.3 ± 2.5) computed inversely from the ultrasonic reflective signals was well compared with that measured from the actual specimens (Skin: 2.5 ± 0.2 , Fat: 11.0 ± 1.4 , Muscle: 8.2 ± 2.2). These findings obtained from the phantom tests support that the customized ultrasound system may be enough reliable detecting an alteration of the rigidity in the soft-tissue layers.

IV. CLINICAL TRIALS AND RESULTS

The customized ultrasound system was finally verified through application to human subjects with/without functional gastrointestinal disorders (Normal and Patient Groups). It was performed to finally identify feasibility of utilization of the customized ultrasound system for diagnosis of the functional gastrointestinal disorders in practical clinics.

A. Participants

Following Institutional Review Board approval, 40 female human subjects (43.3 ± 12.4 years) were randomized into two groups: 20 normal subjects were assigned to control group and 20 patient subjects with symptoms related to the functional gastrointestinal disorders were assigned to patient group.

B. Clinical Application and Analysis

Same region on the abdomen of the human subjects was selected and palpated using the customized ultrasound system (Fig. 5). The ultrasonic reflective signals were then acquired by a monitoring program customized by Labview 7.1 (National Instruments, Austin, Texas, USA). It was analyzed via comparison of the reflective signals obtained from the normal and patient groups. Here, a paired student's t-test was used to identify a significant difference between the normal and patient groups. The significance level was then set at 0.05.



Fig. 6 Palpation on the abdomen using the customized ultrasound system for diagnosis of the functional gastrointestinal disorders

Fig. 7 showed the representative ultrasonic responses for the normal and patient groups. For the normal group, the maximum amplitudes of the ultrasonic reflective signals at the boundary of the gastrointestinal tract well (0.1 ± 0.2 Vp-p) were similar to those at the skin and fat layers (0.2 ± 0.3 Vp-p) ($p > 0.05$). This indicates that the material characteristics (*i.e.*, density, acoustic impedance, and elastic modulus) are similar for all soft-tissues inside the abdomen. For the patient group, the maximum amplitudes of the ultrasonic reflective signals at the boundary of the gastrointestinal tract well (2.6 ± 0.3 Vp-p) were high relative to those at the skin and fat layers (0.3 ± 0.2 Vp-p) ($p < 0.05$). This finding may indicate that the gastrointestinal tract well is rigid due to reasons induced by the functional gastrointestinal disorders. The reasons will be discussed at following section. The results showed that the maximum reflective signals at the boundary near to the gastrointestinal tract well for the patient group were generally higher than those in the normal group ($p < 0.05$). Here, the maximum amplitudes of the ultrasonic reflective signals at the boundary of the gastrointestinal tract well were generally appeared at 20mm depth approximately from abdominal skin for all human subjects. This finding was favorably corresponded to the location of the boundary of the actual gastrointestinal tract well.

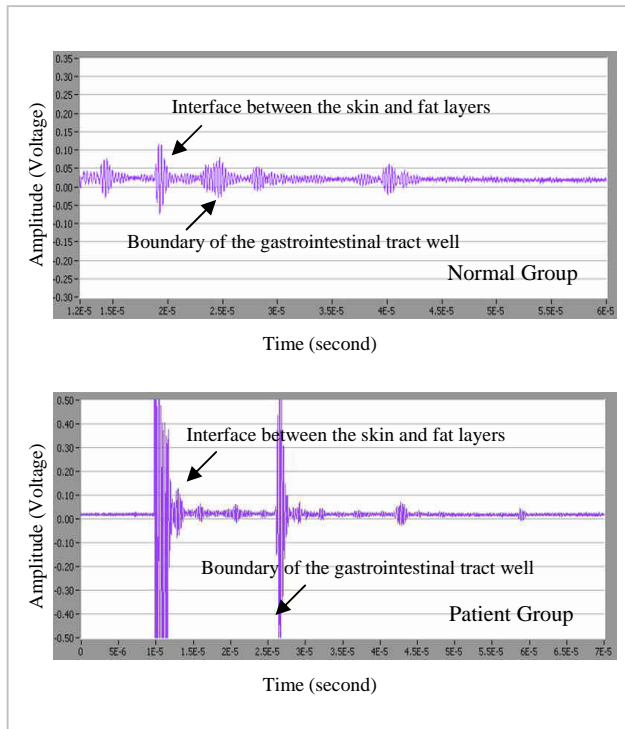

Fig. 7 A representative reflective signal of ultrasound for normal and patient groups

V. DISCUSSIONS AND CONCLUSIONS

Current study shows the customized ultrasound system may be able to detect effectively an alteration of rigidity in the gastrointestinal tract well, which can be induced by the functional gastrointestinal disorders. It can be supported the explicit fact that characteristics of ultrasound responses are changed corresponding to alterations in materials composed objects. However, it has been not attempted to develop an ultrasound system for the diagnosis of the functional gastrointestinal disorders. It may be due to difficulty in identification of symptoms (*i.e., rigidity of the gastrointestinal tract well identified in this study*) of the functional gastrointestinal disorders. This study may be, therefore, valuable as first attempt to diagnose quantitatively the functional gastrointestinal disorders.

The number of patients who have the functional gastrointestinal disorders is increasing in recent years. The functional gastrointestinal disorders induce directly abnormal function in gastrointestinal motility, which is defined by the movement of the digestive system, and the transit of the contents within it [1]. This abnormal gastrointestinal motility can develop various symptoms (*i.e., heartburn, nausea, constipation, dyspepsia, tympanites, vomiting, and diarrhea*), resulting in leaving the patients unable to fully participate in life and work in a severe case. This abnormal gastrointestinal motility may also produce a toxin, which can be absorbed into the gastrointestinal tract, resulting in a breakdown in the

function of the nerve and cellular system in any portion of gastrointestinal tract. The consecutive breakdown may cause physiological problems in the gastrointestinal tract well (*i.e., rigor of the tract well*).

Our research group identified recently that the gastrointestinal tract well in patients with the functional gastrointestinal disorders becomes more rigid than that in healthy people when palpating the abdominal regions overlaying the gastrointestinal tract well. This may be explained by the pacemaker mechanisms underlying the gastrointestinal autonomic rhythmic motility. It is widely accepted that Interstitial Cells of Cajal (ICC) drives spontaneous rhythmic motility in the integrative control of the gastrointestinal function [7, 8]. Here, this ICC form networks widely distributed within the submucosal, intra-muscular and inter-muscular layers of the gastrointestinal tract well from the esophagus to the internal anal sphincter [7, 8]. Considerable researchers reported the ICC affected intracellular Ca^{2+} handling, which plays a critical role in generation of pacemaker for the spontaneous rhythmic motility, although respective players such as the Ca^{2+} -ATPase of the sarcoplasmic reticulum (endoplasmic reticulum), IP3 receptors, ryanodine receptors and plasma membrane ion channels might have divergent roles in the Ca^{2+} release-refilling cycles [8-10]. Based on these facts, it may be expected that abnormalities of the ICC induced by a toxin absorbed into the gastrointestinal tract well generate abnormal function of intracellular Ca^{2+} handling. This may result in a rigor of the gastrointestinal tract well by abnormally successive contraction of the smooth muscle composed the tract well. It is because the contraction of the smooth muscle is controlled by the excitation-contraction coupling mechanism regulated by Ca^{2+} pump [11].

There are limitations related to following issues; 1) in material properties in the FD models used for representation of the rigid conditions, 2) in chemical treatment to simulate the rigid condition in the actual specimens 3) in assumption of the reasons related to the change of the rigidity of the gastrointestinal tract well. These limitations will be solved through our ongoing study incorporated with molecular biological studies related to the functional gastrointestinal disorders.

ACKNOWLEDGMENT

This research was supported by Regional Research Center Program which was conducted by the Ministry of Commerce, Industry and Energy of the Korean Government.

REFERENCES

- [1] International Foundation for Functional Gastrointestinal Disorders. "Gastrointestinal functional and motility disorders". Available: <http://www.iffgd.org/GIDisorders/GImain.html> 2006.
- [2] N. J. Talley, V. Stanghellini, R. C. Heading, K. L. Koch, J. R. Malagelada, and G. N. Tytgat. "Functional gastrointestinal disorders". Gut, 45:1137-1142, 1999.

- [3] W. G. Thompson, G. F. Longstreth, D. A. Drossman, K. W. Heaton, E. J. Irvine, and S. A. Muller-Lissner. "Functional bowel disorders and functional abdominal pain". *Gut*, 45:1143-1147, 1999.
- [4] C. Rubin, M. Bolander, J. Ryaby, and M. Hadjiargyrou. "The use of low-intensity ultrasound to accelerate the healing of fractures". *J. Bone Joint Surg.*, 83A:259-270, 2001.
- [5] R. St John Brown. "How safe is diagnostic ultrasonography". *J Can Med Assoc*, 131:307-311, 1984.
- [6] T. Szabo. "Diagnostic Ultrasound Imaging: Inside Out ". Elsevier Inc., London, 2004.
- [7] K. W. Min and M. Leabu. "Interstitial Cells of Cajal (ICC) and Gastrointestinal Stromal Tumor (GIST): facts, speculations, and myths." *J. Cell Mol Med.* , 10:995-1013, 2006.
- [8] M. Takaki. "Cut pacemaker cells: the interstitial cells of cajal (ICC)". *J. Smooth Muscle Res.*, 39:137-161, 2003.
- [9] K. D. Keef, D. C. Murray, K. M. Sanders, and T. K. Smith. "Basal release of nitric oxide induces an oscillatory motor pattern in canine colon". *J. Physiol.*, 499:773-786, 1997.
- [10] T. K. Smith, J. B. Reed, and K. M. Sanders. "Interaction of two electrical pacemakers in the muscularis of the canine proximal colon". *Am. J. Physiol.*, 252:C290-C299, 1987.
- [11] A. C. Guyton and J. E. Hall. "Textbook of medical physiology". 10 ed. W.B. Saunders, Philadelphia, 2000.