

# Two Kinds of Self-Oscillating Circuits Mechanically Demonstrated

Shiang-Hwua Yu, Po-Hsun Wu

**Abstract**—This study introduces two types of self-oscillating circuits that are frequently found in power electronics applications. Special effort is made to relate the circuits to the analogous mechanical systems of some important scientific inventions: Galileo's pendulum clock and Coulomb's friction model. A little touch of related history and philosophy of science will hopefully encourage curiosity, advance the understanding of self-oscillating systems and satisfy the aspiration of some students for scientific literacy. Finally, the two self-oscillating circuits are applied to design a simple class-D audio amplifier.

**Keywords**—Self-oscillation, sigma-delta modulator, pendulum clock, Coulomb friction, class-D amplifier.

## I. INTRODUCTION

MANY textbooks on basic circuit theory overemphasize circuit analysis methods, but lack real applications to explain the uses of circuits. Consequently, students tend to know how to lay bricks, but not know how to build a beautiful chapel or cathedral. This work develops a lecture on basic LCR circuits and self-oscillating circuits [1]-[6] by using analogy in mechanical systems and introducing some related scientific history, hopefully providing some demonstrations and stimulation for students. Two types of self-oscillating circuits are introduced here. Both find uses in power electronics applications, one useful for self-oscillating power amplification [3], [4] and the other for pulse width modulation [5], [6]. The lecture is designed using the following two pedagogic strategies:

- 1) Use of analogy: A major part of human creativity and thinking is based on analogy and metaphor [7]. Teaching by analogy is especially effective, since previous knowledge or experience helps build meaning of the new materials. The LCR circuit is first introduced as an electrical analog of a mass-spring-damper system. The LCR-based oscillator and modulator are then presented by analogy with a mechanical clock and an imaginary friction mechanism, respectively.
- 2) Introduction of the scientific history and philosophy: The lecture relates the LCR self-oscillating circuits with two important scientific inventions in the seventeenth and eighteenth centuries: Galileo's pendulum clock [8], [9] and Coulomb's friction model [10]. By considering the history and the underlying philosophy of science, students can

gain a deeper understanding of the presented circuit and appreciate the intelligence of historical figures in science.

## II. LCR OSCILLATOR

A square-wave oscillator, which generates regularly spaced pulses, is an essential component of many digital instruments and systems. An LCR oscillator that uses positive relay feedback around an LCR circuit to generate a stable oscillation is a particularly interesting design. Such an LCR oscillator can be viewed as a direct descendant of the mechanical clocks inspired by Galileo.

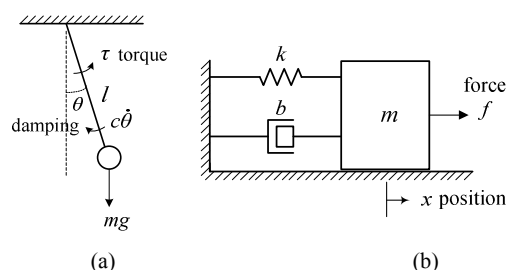

Fig. 1 (a) A pendulum with the damping proportional to the angular velocity (b) Mechanical analog of the linearized pendulum, where  $m$ ,  $b$ ,  $k$ , and  $f$  corresponds to the moment of inertia  $m^2$ ,  $c$ ,  $mg$ , and  $\tau$  in a damped pendulum. The linear damping is to account for air drag and friction

### A. Galileo's Pendulum Clock

Galileo Galilei (1564-1642) discovered the pendulum's isochronic property by observing a swaying lamp hanging from a cathedral ceiling in the late sixteenth century [8]. A pendulum that does not swing too widely swings at a constant period, irrespective of mass and amplitude. Galileo realized that this isochronic property could be useful in measuring time periods, and mentioned to his son Vincenzo the idea of utilizing a pendulum to build a clock in 1641. However, Vincenzo never succeeded in building such a clock. Dutch physicist Christiaan Huygens (1629-1695) constructed the first working pendulum clock in 1656, and later published books about its design and the improvement, named *Horologium* in 1658 and *Horologium Oscillatorium* in 1673, respectively. Later Robert Hooke and Huygens independently invented a new mechanical oscillator to replace a pendulum in 1675. Their oscillator comprised a balance wheel attached to a coil spring that rotated back and forth due to the elasticity of a spring. This design became a prototype for modern mechanical wristwatches. John Harrison (1693-1776) later significantly improved clock accuracy in his lifelong pursuit of an accurate and reliable clock to solve the long-standing problem of longitude determination [11].

The authors are with the electrical engineering department of National Sun Yat-Sen University, 70 Lien-Hai Road, Kaohsiung, Taiwan (e-mail: shaun@mail.ee.nsysu.edu.tw).

This work was supported by National Science Council, Taiwan, under Grant NSC 102-2221-E-110-068.

The invention of a pendulum clock had a major impact on scientific development, and marks the beginning of dynamic mechanics. Physical quantities involving time could not easily be measured before this invention. Newton's incomparable work *Principia* would almost certainly not have been possible without the invention of the pendulum clock [12].

### B. Perpetual Oscillation of a Mechanical Clock

The most important components of a mechanical clock are the oscillator and the regulator [13], [8]. The oscillator is a pendulum or a balance wheel with a spring, and the regulator is a device called an escapement, which supplies energy to the oscillator and regulates the motion of the clock. Fig. 1 shows simple models for common mechanical oscillators. The equation of the mass-spring-damper oscillator is given by

$$m\ddot{x} + b\dot{x} + kx = f. \quad (1)$$

Considering an initial energy and zero external force, the mass-spring-damper system oscillates at a rate given by

$$\omega = \sqrt{\frac{k}{m} - \left(\frac{b}{2m}\right)^2}. \quad (2)$$

The oscillation frequency is independent of the amplitude (isochronic property), and is close to the undamped natural frequency  $(k/m)^{0.5}$  when the damping is very small. However, this oscillator is not suitable for measuring long time periods, because, without a supply of energy, the oscillator will eventually stop because of unavoidable damping caused by friction and air drag. Equation (1) multiplied by  $\dot{x}$  yields,

$$\frac{d}{dt} \left( \frac{1}{2} m \dot{x}^2 + \frac{1}{2} k x^2 \right) = f \dot{x} - b \dot{x}^2. \quad (3)$$

The left-hand side of (3) is the changing rate of the stored energy. Without an external force (i.e.,  $f=0$ ), the damping eventually consumes all the stored energy, causing the oscillation to stop. The oscillation can only be sustained by exerting a force on the mass along its direction of movement to compensate the energy loss. The important issue is finding an effective method of supplying energy without affecting the oscillation frequency. The impulse response is known to have the same oscillation frequency as the natural response. Additionally, as implied by (3), an impulsive force is most effective when applied at the instant of the mass passing its equilibrium (i.e.,  $x=0$ ), since the velocity reaches maximum at the equilibrium. Hence, exerting impulsive forces upon the mass at the instants of time when  $x=0$  enhances its oscillation [1, Sec. III-5]. The resulting impulse responses oscillate at the same frequency, with their zero-crossings coinciding with that of the original oscillation. Superimposing such an impulse response is completely constructive, making it the most effective technique for a clock's escapement to compensate for the energy loss of a mechanical oscillator. The video presentation of professor Sussman [13] provides an excellent demonstration of the escapement mechanism.

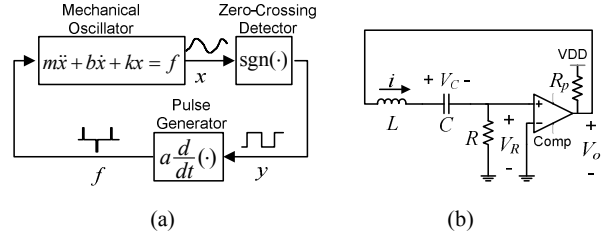

Fig. 2 Relay feedback for sustained oscillation of a mechanical clock (a) Schematic demonstration (b) Electrical analog, where  $L$ ,  $C$ ,  $R$ , and  $V_R$  corresponds to  $m$ ,  $1/k$ ,  $b$ , and  $x$  in the mechanical system, respectively. An additional pullup resistor  $R_p$  is required for the comparator that has an open-collector or open-drain output

### C. Electrical Analog of a Mechanical Clock

Fig. 2 (a) mathematically illustrates the energy-supply mechanism of a mechanical clock. The signum function  $\text{sgn}(x)=1$  when  $x \geq 0$ , otherwise  $\text{sgn}(x) = -1$  detects the zero-crossings of  $x$ , producing a binary output  $y$  that alters its state at each zero-crossing. A differentiator transforms the square wave  $y$  into an impulse train  $f$ , with positive impulses occurring at the rising edges of the square wave, and negative impulses at the falling edges. The dynamics of the overall feedback energy-supply mechanism is described by

$$\begin{cases} m\ddot{x} + b\dot{x} + kx = a\dot{y} \\ y = \text{sgn}(x). \end{cases} \quad (4)$$

Fig. 2 (b) presents an electrical realization of this feedback oscillation, of which the equations are as follows

$$\begin{cases} L\ddot{V}_R + R\dot{V}_R + \frac{1}{C}V_R = R\dot{V}_o \\ V_o = \text{sgn}(V_R). \end{cases} \quad (5)$$

In analogy with the mechanical clock, the oscillation frequency of this LCR oscillator is exactly equal to the natural frequency of the series LCR in the circuit. By direct one-to-one correspondence with (2), the oscillation frequency is given by

$$\omega = \sqrt{\frac{1}{LC} - \left(\frac{R}{2L}\right)^2}. \quad (6)$$

This kind of self-oscillation can be applied to the design of self-oscillating electronic drive [3], [4].

### III. LCR MODULATOR

This section introduces another type of oscillator that can carry the information of the external signal in its varying pulse-width of oscillation [5], [6]. The most well-known of these pulse-width modulated oscillators are sigma-delta modulators [5], [14], which have various applications in signal coding, analog-to-digital conversion and communication. Of particular interest is their intimate connection with an imaginary mechanical oscillator.

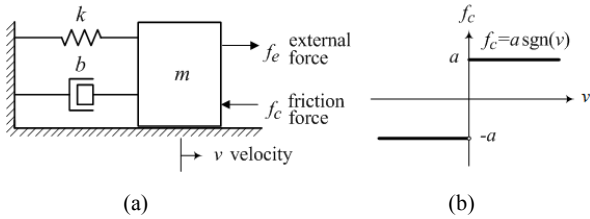

Fig. 3 (a) Mass-spring-damper system with friction; (b) Binary representation of the Coulomb friction model,  $f_c = a$  when  $v \geq 0$ , otherwise  $f_c = -a$ , where  $a$  is proportional to the normal force of the block to the surface

#### A. Coulomb's Friction Model

Friction is a common experience in our daily life. A small force to push a heavy object causes no motion until the force exceeds a certain minimum level. Leonardo da Vinci (1452–1519) first systematically studied of friction by discovering that friction is proportional to the weight and is independent of the area of contact. These two laws of friction were rediscovered by the French physicist Guillaume Amontons in 1699, and later augmented by Coulomb in 1785. D. Dowson [15] provides a complete history of the discovery and investigation of friction. Charles Augustin Coulomb (1736–1806), who is best known for Coulomb's law in electrostatic force, proposed a simple mathematical model for friction in 1785.

$$f_c = a \operatorname{sgn}(v), \quad (7)$$

where the constant  $a$  is proportional to the normal force  $mg$ , with the proportionality depending on the materials of the surfaces in contact.

In the binary representation of Fig. 3 (b), the Coulomb friction switches between two extreme values, and does not disappear even when the block is at rest. Suppose that the block in Fig. 3 (a) has zero velocity at the origin, and that the Coulomb friction force is larger than the external force. In this case, the Coulomb friction force repetitively pushes the block back and forth according to the sign of the velocity, restricting its motion within an extremely small region. Since no humane eye or equipment in the world can detect such an infinitely high-frequency and infinitesimally small movement, the block is observed to be "at rest". The external force does not disturb this state unless it exceeds the magnitude of the friction force. The phenomenon described by this model is consistent with our observation, although it seems difficult to accept intuitively.

The Coulomb's binary friction model can be applied without necessarily believing in it, because a mathematical model is only a simplified analogous construct of physical reality [16], just as Newton's laws is a model of bodies in motion. A mathematical model is generally consonant with empirical findings, but not identical with nature. The mathematical principle or model needs modification when it is not consistent with the observations of nature. Various modifications of the Coulomb friction model have been made by comparing and contrasting it with the reality of nature [10].

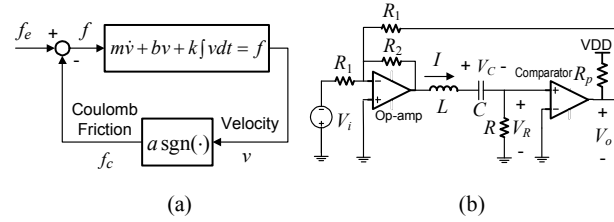

Fig. 4 (a) Block diagram of a mass-spring-damper system with Coulomb friction. (b) Electrical analog: LCR modulator, where  $L$ ,  $C$ ,  $R$ ,  $V_R$ ,  $V_i$  and  $V_o$  corresponds to  $m$ ,  $1/k$ ,  $b$ ,  $v$ ,  $f_e$ , and  $f_c$  in the mechanical system, respectively

#### B. Coulomb Friction Oscillator: Binary Representation of a Continuous Force

Except for its practical use in estimating friction, the binary Coulomb friction model suggests a clever way to transform a continuous signal into a binary one.

Consider the mass-spring-damper system with binary Coulomb friction shown in Fig. 6 (a). The mass oscillates infinitely fast in an infinitesimally small region when the external force is below the Coulomb friction. Such a system is referred to herein as a Coulomb friction oscillator. Macroscopically, the block of mass does not make an observable movement, even though the total net force on it is not zero at any moment. This is because a body in motion is a memory system, which reacts to a force by accelerating, and its motion (i.e., velocity and position) is the result of the accumulation of all past forces. Therefore, the body barely moves if the effects of the net forces exerted at different instants tend to cancel each other out. In other words, the body cannot "feel" the difference between the continuous external force and the binary friction, and therefore responds with no observable movement. This can be interpreted in the frequency domain as meaning that the binary friction has identical frequency content to the continuous external force within the bandwidth of the mass-spring-damper system. The mass-spring-damper system completely filters out their difference. Therefore, the continuous external force can be reconstructed from the binary friction by filtering out those out-of-band differences.

#### C. Electrical Analog of a Coulomb Friction Oscillator

Fig. 4 (a) displays a block diagram of the Coulomb friction oscillator in Fig. 3 (a). Fig. 4 (b) depicts an analogous circuit realization in which the series LCR mimics the mass-spring-damper system with input  $V_i$ , comparator output  $V_o$  and resistor voltage  $V_R$  corresponding to external force  $f_e$ , friction  $f_c$  and velocity  $v$ , respectively. The  $s$ -domain model of the LCR circuit is given below to examine the relationship between the continuous input and the binary output.

$$T(s)[V_i(s) - V_o(s)] = V_R(s), \quad (8)$$

where

$$T(s) = \frac{(R/L)s}{s^2 + (R/L)s + 1/(LC)}. \quad (9)$$

Alternatively, (8) can be recast as

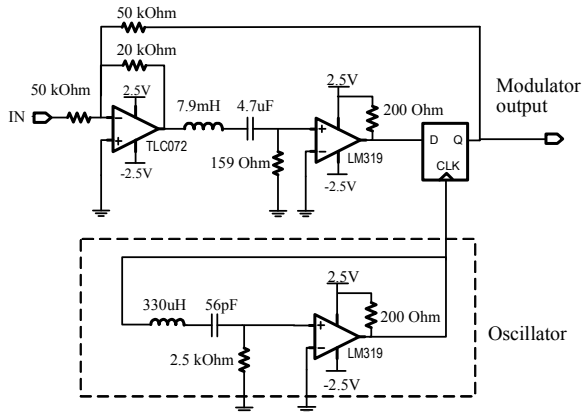

Fig. 5 Sigma-delta modulator clocked by a square-wave oscillator

$$V_o(s) = V_i(s) - T^{-1}(s)V_R(s). \quad (10)$$

The comparator output  $V_o$ , which is a binary representation of the input signal  $V_i$  and unwanted noise  $T^{-1}V_R$ . By analogy,  $V_R$  corresponds to the velocity of the mass-spring-damper system, and is close to zero when  $|V_i| < |V_o|$  (which corresponds to the condition that the external force is below the Coulomb friction in the mechanical system). Significantly,  $T$  is a bandpass filter, and its inverse magnitude response spectrally shapes the frequency content of the noise. This means that the in-band noise will be attenuated, and  $V_o$  contains mostly the input signal  $V_i$  within the bandwidth of the bandpass LCR. Such a modulator belongs to a group of noise-shaping modulators named sigma-delta modulators [5]

#### IV. COMPARISON AND APPLICATION

This work presents two oscillators that utilize relay feedback. This section highlights their differences, and also presents an application for them.

##### A. Comparison of LCR Oscillator and Modulator

The LCR oscillator and modulator in Figs. 2 (b) and 4 (b) are similar in structure, but very different in operation. They belong to the same category of feedback called relay feedback, and are designed to be self-oscillatory. However, the LCR oscillator oscillates at the natural frequency of the LCR, whereas the LCR modulator tends to oscillate at an extremely high frequency; the former carries the information of the natural response of the LCR, but the latter carries the information of the external input signal. The difference is caused by the sign of the feedback. According to the law of energy conservation, the changing rate of the total stored energy of the inductor and capacitor equals the supply power minus the power dissipated on the resistor. This law is expressed mathematically as follows:

$$\frac{d}{dt} \left( \frac{1}{2} LI^2 + \frac{1}{2} CV^2 \right) = IV_s - RI^2 = \frac{1}{R} V_R V_s - RI^2. \quad (11)$$

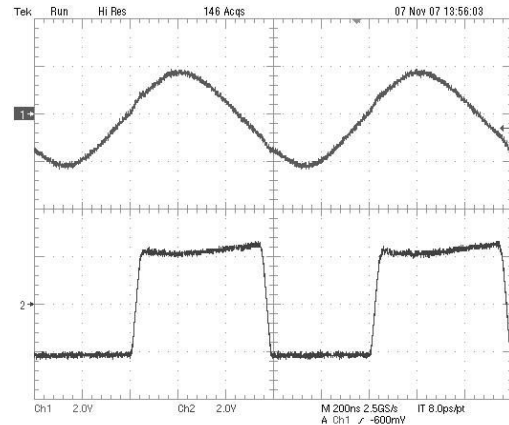
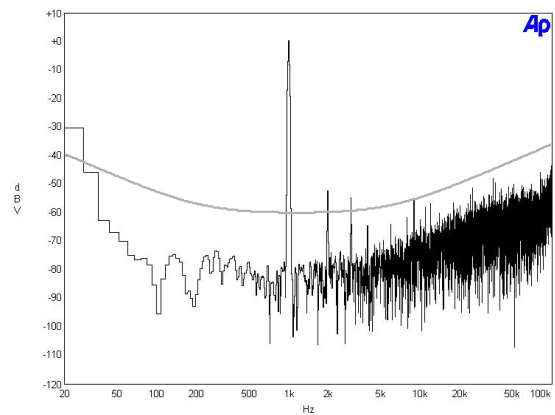

Fig. 6 Waveforms of the resistor voltage and the comparator output in the designed LCR oscillator

 Fig. 7 Output spectrum of the clocked modulator (black) and the magnitude response of  $(10^3 T)^{-1}$  (gray). The noise spectrum follows the shape of the magnitude response of  $T^{-1}$ 

The voltages  $V_s$  for the LCR oscillator and modulator are respectively,

$$\text{Oscillator: } V_s = \text{sgn}(V_R); \quad (12)$$

$$\text{Modulator: } V_s = V_i - \text{sgn}(V_R). \quad (13)$$

In the oscillator, the feedback of the comparator output makes the first term on the right-hand side of (11) positive, supplying energy to the LCR and sustaining oscillation of the LCR. However, in the modulator, the feedback drains energy out of the LCR in an attempt to cancel the external input and steer the state of the LCR to its equilibrium.

##### B. Application: Class-D Speech Amplifier

This section combines the LCR oscillator and modulator with a half bridge of power transistors to construct a class-D speech amplifier [17]. Figs. 5 and 8 display the designed circuit. In Fig. 5, the modulator converts a continuous input speech signal into a binary signal, and a D-type flip-flop is inserted at the output of the modulator to sample and hold the output signal at a rate of 1 MHz set by the LCR oscillator. The oscillation

frequency of the LCR oscillator with the chosen LCR parameters, according to (6), is  $\omega=6.3E6$  rad/sec, roughly 1 MHz. The experimental result is consistent with the theoretical expectation. The waveforms of the oscillator are displayed in Fig. 6. A modulator with the LCR parameters shown in Fig. 5 has its frequency band in the major speech frequency range, namely from 200Hz to 3.4 kHz. Fig. 7 shows the output spectrum of the modulator in response to a 1 kHz sinewave input. As expected, the modulator output spectrum contains an isolated tone at 1 kHz and noise that distributes following the shape of the magnitude response of  $T^{-1}$ , where  $T$  is the transfer function of the LCR bandpass filter in the modulator, as given in (9). A slight rise of the output spectrum near DC is caused by the DC offsets of the amplifier and the comparator.

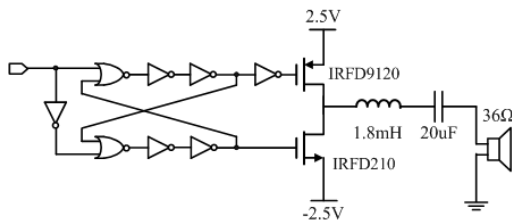

Fig. 8 A non-overlapped circuit and a half bridge of MOSFET transistors make a simple class-D power amplifier and its output LC circuit together with a  $36\Omega$  earphone forms a bandpass filter

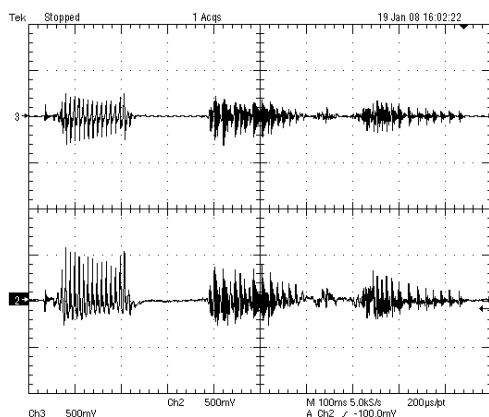

Fig. 9 Speech signal "God bless you" as an test input to the proposed class-D amplifier (channel 2) and its reconstructed waveform on the earphone at the output (channel 3)

Fig. 8 shows the proposed class-D amplifier that reproduces the speech from the binary signal sent from the modulator. The class-D amplifier comprises a non-overlapped circuit and a pair of P-channel and N-channel power MOSFETs. The non-overlapped circuit controls the alternately conducting PMOS and NMOS, turning off one transistor first and delaying the turn-on of the other transistor by about 50 ns to prevent two transistors from conducting simultaneously during the switching transitions. The amplifier drives an earphone. The earphone combined with an inductor and a capacitor constitutes an LCR bandpass filter with its passband from 200Hz to 3.4 kHz, recovering the speech signal as a reproducing sound from

the binary signal by filtering out the out-of-band modulation noise. Fig. 9 plots the waveforms of a test speech signal as the input to the modulator and its reconstructed signal across the earphone driven by the class-D amplifier. The measurement shows that the proposed pulse width modulated amplifier has total harmonic distortion plus noise of 0.4% for a 1V peak-to-peak sinewave input, a quality comparable to a telephone.

## V. CONCLUSION

This short lecture introduces two common types of self-oscillating circuits and their connections to Galileo's pendulum clock and Coulomb's friction model. These analogies help describe, visualize and make sense of the unintuitive aspects of electrical world, thus promoting greater understanding of the two different self-oscillating circuits and their possible applications. Furthermore, meandering through the related scientific history and philosophy should help correct the serious imbalance between engineering competence and scientific literacy in the current engineering education.

## REFERENCES

- [1] A. A. Andronow and C. E. Chaikin, *Theory of Oscillations*, English Language Edition, edited by S. Lefschetz, Princeton University Press, Princeton, 1949.
- [2] A. Jenkins, "Self-oscillation," *Physics Reports*, Vol. 525, Issue 2, pp. 167-222, April 2013.
- [3] A. R. Seidel, F. E. Bisogno, and R. N. do Prado, "A design methodology for a self-oscillating electronic ballast," *IEEE Trans. Power Electron.*, vol. 43, no. 6, pp. 1524-1533, Nov./Dec. 2007.
- [4] S. Voronina and V. Babitsky, "Autoresonant control strategies of loaded ultrasonic transducer for machining applications," *Journal of Sound and Vibration*, 313, pp. 395-417, 2008.
- [5] Jurgen van Engelen and Rudy J. van de Plassche, *Bandpass Sigma Delta Modulators: Stability Analysis, Performance and Design*, Kluwer Academic Publishers, 1999.
- [6] S. H. Yu, T. Y. Wu, and S. H. Wang, "Extension of Pulse Width Modulation from Carrier-Based to Dither-Based," *IEEE Trans. Industrial Informatics*, Vol. 9, No. 2, pp. 1029-1036, May 2013.
- [7] G. Lakeoff and M. Johnson, *Metaphors We Live By*. Chicago: University of Chicago Press, 1980.
- [8] G. L. Baker and J. A. Blackburn, *The Pendulum: A Case Study in Physics*, Oxford University Press, New York, 2005.
- [9] M. R. Matthews, *Time for Science Education: How Teaching the History and Philosophy of Pendulum Motion Can Contribute to Science Literacy*, Kluwer Academic/Plenum Publishers, New York, 2000.
- [10] H. Olsson, K. J. Åström, C. Canudas de Wit, M. Gäfvert, and P. Lischinsky, "Friction models and friction compensation," *European Journal of Control*, vol. 3, pp. 176-195, 1998.
- [11] D. Sobel, *Longitude: The Story of a Lone Genius Who Solved the Greatest Scientific Problem of His Time*, Penguin Books, 1995.
- [12] R. S. Westfall, "Making a world of precision: Newton and the construction of a quantitative world view," *Some Truer Method: Reflections on the Heritage of Newton*, edited by F. Durham and R. D. Purrington, Columbia University Press, New York, 1990.
- [13] G. Sussman, "An electrical engineering view of a mechanical watch," MIT World Video <http://video.mit.edu/watch/an-electrical-engineering-view-of-a-mechanical-watch-9035/>.
- [14] S.H. Yu, "Analysis and design of single-bit sigma-delta modulators using the theory of sliding modes," *IEEE Transactions on Control Systems Technology*, Vol. 14, No. 2, pp. 336-345, 2006.
- [15] D. Dowson, *History of Tribology*, Longman Group Ltd., New York, 1979.
- [16] B. Cohen, "Newton's method and Newton's style," *Some Truer Method: Reflections on the Heritage of Newton*, edited by F. Durham and R. D. Purrington, Columbia University Press, New York, 1990.
- [17] E. Gaalaas, "Class D audio amplifiers: what, why, and how," *Analog Dialogue*, vol. 40, no. 2, pp. 6-12, June, 2006.