

Twin-Screw Extruder and Effective Parameters on the HDPE Extrusion Process

S. A. Razavi Alavi, M. Torabi Angaji, and Z. Gholami

Abstract—In the process of polyethylene extrusion polymer material similar to powder or granule is under compression, melting and transmission operation and on base of special form, extrudate has been produced. Twin-screw extruders are applicable in industries because of their high capacity. The powder mixing with chemical additives and melting with thermal and mechanical energy in three zones (feed, compression and metering zone) and because of gear pump and screw's pressure, converting to final product in latest plate. Extruders with twin-screw and short distance between screws are better than other types because of their high capacity and good thermal and mechanical stress.

In this paper, process of polyethylene extrusion and various tapes of extruders are studied. It is necessary to have an exact control on process to producing high quality products with safe operation and optimum energy consumption.

The granule size is depending on granulator motor speed. Results show at constant feed rate a decrease in granule size was found with increase in motor speed. Relationships between HDPE feed rate and speed of granulator motor, main motor and gear pump are calculated following as:

$$x = \text{HDPE feed flow rate, } y_M = \text{Main motor speed}$$

$$y_M = (-3.6076e-3) x^4 + (0.24597) x^3 + (-5.49003) x^2 + (64.22092) x + 61.66786 \quad (1)$$

$$x = \text{HDPE feed flow rate, } y_G = \text{Gear pump speed}$$

$$y_G = (-2.4996e-3) x^4 + (0.18018) x^3 + (-4.22794) x^2 + (48.45536) x + 18.78880 \quad (2)$$

$$x = \text{HDPE feed flow rate, } y = \text{Granulator motor speed}$$

$$\text{10th Degree Polynomial Fit: } y = a+bx+cx^2+dx^3\dots \quad (3)$$

$$a = 1.2751, \quad b = 282.4655, \quad c = -165.2098,$$

$$d = 48.3106, \quad e = -8.18715, \quad f = 0.84997$$

$$g = -0.056094, \quad h = 0.002358, \quad i = -6.11816e-5$$

$$j = 8.919726e-7, \quad k = -5.59050e-9$$

Keywords—Extrusion, Extruder, Granule, HDPE, Polymer, Twin-Screw extruder.

I. INTRODUCTION

POLYMER extrusion, as one of the most important polymer processing methods, is a very complex and

S. A. Razavi Alavi is with the Department of Engineering, Islamic Azad University, Shahroud, Shahroud branch.ir. Iran (e-mail: Razavi17@gmail.com).

M. Torabi Angaji, is with the Department of Chemical Engineering, Tehran University, Tehran, Iran (corresponding author to provide phone: +98912-2978240; fax: +9821-66957784; e-mail: mtorabi@ut.ac.ir).

Z. Gholami is with the Department of Engineering, Islamic Azad University, Shahroud, Shahroud branch.ir. Iran (e-mail: Zgholami@gmail.com).

involves the following:

1. Preparation and feeding polymer powder to the extruder
2. Complex mixing, melting, forced flow with moving solid boundaries of extruder screw(s), and heating and cooling of the melt to desired conditions [1].

The final extruder profile dimensions and its consistency and accuracy, depend on: (a) overall material properties, (b) extruder mechanical design, and (c) overall process control, including mechanical (kinematics and dynamics), material flow pressure and temperature, and environmental conditions. This is further complicated in polymer processing due to the

fact that its critical viscoelastic properties are highly non-linear and dependent on stress-strain and temperature, thus highly dependent on overall velocity and temperature profile which in turn are dependent on extruder dimensions, and process parameters and control [1].

II. POLYETHYLENE EXTRUSION

In the process of polyethylene extrusion polymer material similar to powder or granule is under compression, melting, transmission operation and on base of special form, extrudate has been produced. The equipment required for this process and producing granule from powder, is extruder. According to their capabilities, extruders have different types, involves:

1. *Mixer*, mixing -homogenization and transmission of polymeric material.
2. *Melting*, transmission-homogenization of molten material fed.
3. *Kneading*, compression -melting and transmission of solid material fed.
4. *Reactive*, chemical reacting -homogenization and material transmission [2].

On these groups, kneading extruders are the most important due to their various applications in industries and seriousness economic. This type includes single-screw and multi-screws.

Irrespective of extruder type and polymeric material used, a kneading extrude should provide these claims:

- A) Entering and transmission of polymeric material
- B) Compression-evaluation and materials melting
- C) Pressure profile formation to eliminate resistances and created continuously and consistency and monotonous molten in extruder's outlet [2]-[3].

In order to make each function as effective as possible it is normal practice to divide the screws into 3 zones. The

function of feed zone is to collect powder from the feed hopper and transport them up the screw channel. At the same time, the powders should begin heat up and compact and build up pressure as they advance towards screw tip (die end). For efficient pumping the powders must not be allowed to lie in the screws channel. They must therefore show high degree of slippage on the screw channel surface and low degree of slipping on the barrel. The compression zone or transition zone could be of two type, 1) gradual transition, long compression zone, 2) sudden transition, short compression zone. The screws with sudden transition are required for plastic material with a narrow melting range such as nylon and

Twin-screw extruders are applicable in industries because of their high capacity. The powder mixing with chemical additives and melting with thermal and mechanical energy in three zones (feed, compression and metering zone) and because of gear pump and screw's pressure, converting to final product in latest plate. Extruders with twin-screw and short distance between screws are better than other types, because of their high capacity and good thermal and mechanical stress.

Out put of the extruder depends on: a) screws dimensions, b) die dimensions, c) screw rpm, the following factor

Will increase out put: 1) increase of screw speed, 2) increase of screw diameter, 3) the helix angle up to a

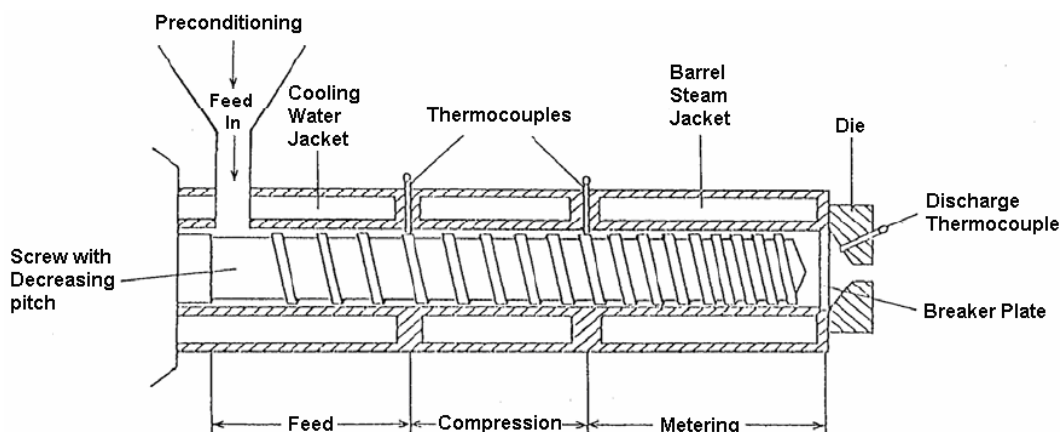

Fig. 1 Single-screw extruder

screws with gradual transition are material with wide melting range. In the melting zone, the polymer melt is brought to correct consistency and pressure required for extrusion. The melt should be pumped to the die at a constant rate, consistency and pressure. These properties may vary from point to point but when measured to a particular point should not change with time. Higher melt pressure is required in the metering zone in order to mix melt to give it constant properties through out hence obtain smooth extrudate [3].

Single-screw extruders usually work on high velocities. Increase in screws speed cause higher friction and subsequently, temperature of polymer increase due to friction in screw length. Some times burning and chemical disintegration of polymer caused due to the heat caused from friction and to prevent from this problem, cooling systems are used.

Single-screw extruder is not suitable for polymers have thermal-mechanical sensibilities (like PVC), because of debility in thermal transmission of polymers and problems in consistency of melt, specially in metering zone [2].

Twin-screw extruders, have a controlled produced heat due to low screw speed and able to have a constant or lower temperature than melting point through extruder length and can use thermostats to supply required heat to melting polymer.

Maximum about 30 degrees, 4) an increase in die diameter [3]. It is necessary to have an exact control on process to producing high quality products with safe operation and optimum energy consumption. Therefore, all operation parameters like temperature and pressure, feed flow rate and grade in different conditions are considered and their relationships and diagrams obtained.

III. RESULTS AND DISCUSSION

A. Variation of Operation Parameters

Melt temperature profiles are very important because they strongly influence the rheological properties of polymer melt and thus affect the quality of the final product. At high temperature, the material may degrade or undesirable side reaction may occur. The range of processing conditions for some material is narrow, this requires accurate melt temperature during processing [4].

Measuring polymer melt temperature in polymer processing equipment is not an easy task due to the fact that the mechanism of flow and heat transfer are very complex, and they affected by one another [5]-[6].

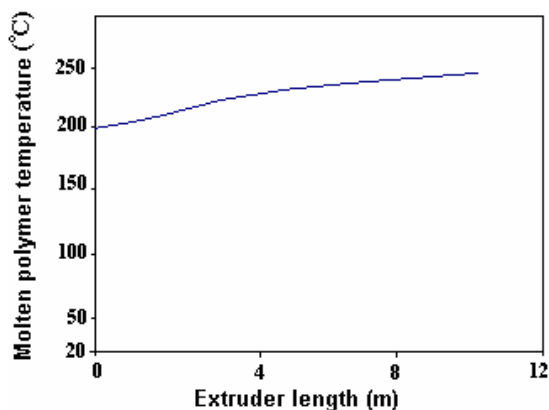

Fig. 1 Temperature profile in twin-screw extruders' length

Temperature of screw and barrel adjust to provide required thermal energy for polymeric material and move continuously through three sections and converting to consistency melt. Experimental results in different conditions show a profile for temperature, shown in Fig. 1.

An exact control on thermal energy transmission to polymeric material is possible to prevent burning and chemical disintegration of polymer, due to thermal control system on cylinder barrel and thermocouples placed on different regions [7].

In this process molten polymer's pressure in gear pump entrance should be 5-7 bar, to have a normal gears work.

After producing melt in cylinder-screw canal, because of screws speed, on base of specially profile, molten polymer exit from die, shown in Fig. 2.

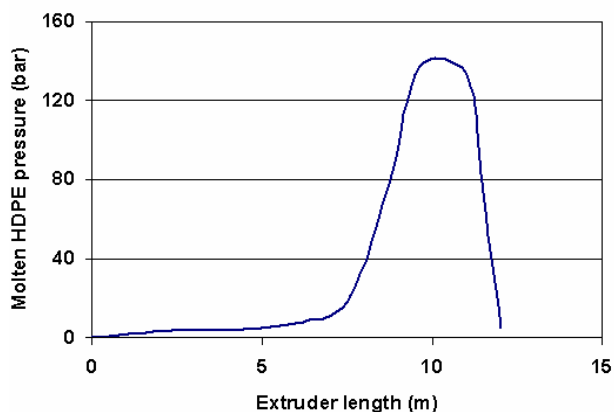

Fig. 2 Pressure profile in twin-screw extruders' length

B. Controller Parameters Relationships

1. Main Motor

In extrusion process, screw speed adjusts proportionate with feed flow rate. Screw speed should increase by main motor before increasing feed flow rate, and then feed enter to hopper.

Main motor speed and feed flow rate increased by controller system to provide mechanical-thermal energy

proportionate whit feed flow rate and have not decrease in melt's quality.

According to experimental results, for a known grade of high density polyethylene powder used in process, relationship between feed flow rate and main motor's speed obtained as shown in Fig. 3 and (1).

$$\begin{aligned} x &= \text{HDPE feed flow rate} \\ y &= \text{Main motor speed} \\ y &= (-3.6076e-3) x^4 + (0.24597) x^3 + (-5.49003) x^2 + \\ & (64.22092) x + 61.66786 \end{aligned} \quad (1)$$

2. Gear Pump

To protect molten polymer's pressure in permitted region, pressure in entrance and outlet of gear pump is proportionate with polymeric material flow rate. Controller adjust the pressure of molten polymer until arrive to die, by increasing the speed of gear pump.

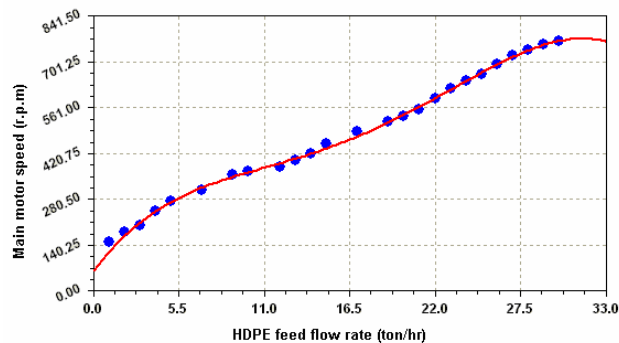

Fig. 3 Variation of main motor speed with feed flow rate

Experimental results, for a known grade of high density polyethylene powder used in process show relationship between feed flow rate and main motor's speed as shown in Fig. 4 and (2).

$$\begin{aligned} x &= \text{HDPE feed flow rate} \\ y &= \text{Gear pump speed} \\ y &= (-2.4996e-3) x^4 + (0.18018) x^3 + (-4.22794) x^2 + \\ & (48.45536) x + 18.78880 \end{aligned} \quad (2)$$

3. Granulator Motor

Pressure and flow rate of melt increased due to increase in feed flow rate, when molten polymer received to granulator unit. Subsequently, speed of granulator motor varies with this flow rate to protect granule size in permitted region. The granule size is depending on granulator motor speed. Results show at constant feed rate a decrease in granule size was found whit Increase in motor speed, shown in Fig. 5, and relationships between HDPE feed rate and speed of granulator motor obtained.

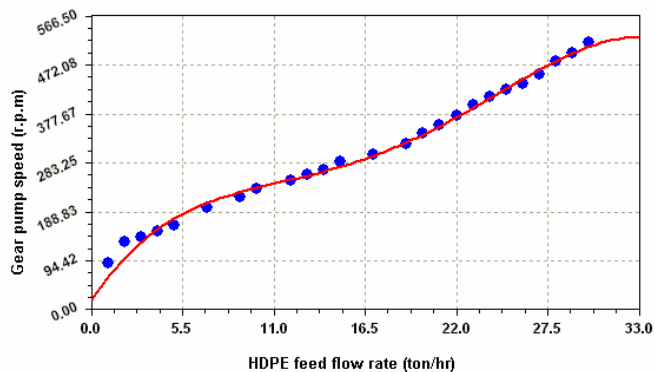

Fig. 4 Variation of gear pump speed with feed flow rate

There is a relationship between HDPE feed rate and granulator motor speed. An increase cause in cut speed to protect granule size in normal region, due to increase in feed flow rate. Granulator unit is a pressure consumer and granulator motor speed should change when a change in feed flow rate happened.

Experimental results show the relation between granulator motor speed and HDPE feed flow rate for a known grade shown in Fig.6, as follow:

x = HDPE feed flow rate

y = granulator motor speed

10th Degree Polynomial Fit: $y = a+bx+cx^2+dx^3...$ (3)

Coefficient Data:

$a = 1.2751$	$d = 48.3106$	$g = -0.056094$
$b = 282.4655$	$e = -8.18715$	$h = 0.002358$
$c = -165.2098$	$f = 0.84997$	$i = -6.11816e-5$
$j = 8.919726e-7$	$k = -5.59050e-9$	

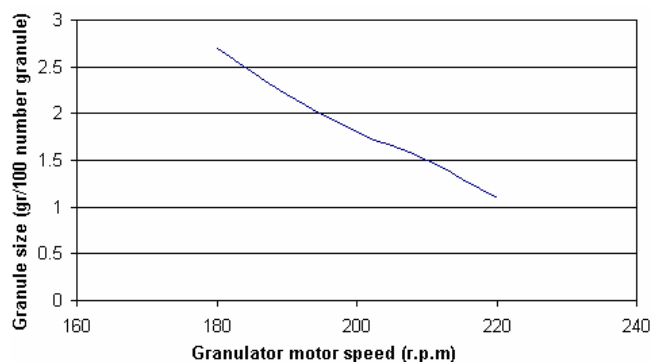

Fig. 5 Variation of produced granule size with granulator motor speed

These results show an excessive relation between feed flow rate and other parameters in extrusion process. Precise and excess knowledge from operation parameters and an exact control is required on this process to produced high quality

products and create the safe process with optimum energy consumption.

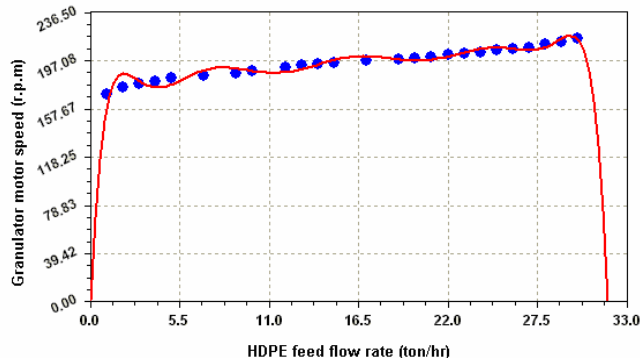

Fig. 6 Variation of granulator motor speed with feed flow rate

IV. CONCLUSION

Twin-screw extruders are applicable in industries because of their high capacity and good thermal and mechanical stress. Results show that a controller system is required for extrusion process. Operation parameters, their relationships obtained and an exact controller system can design for this process according to these results.

REFERENCES

- [1] M. Kostis, Polymer Extrusion Simulation and Die Design: Grand Challenge and Opportunity, www.kostic.niu.edu/extrusion, 2002.
- [2] Chris Rauwendaal, Polymer Extrusion, Fourth Edition, Hanser Gardner Publisher, 2001.
- [3] Prabodh C. Bolur, Extrusion of thermoplastics, technical papers, http://bolur.plastasia.com, 1998.
- [4] N. Sombatsompop, M. Panapoy, Comments on temperature profile of PP melt in the barrel of twin screw extruder, polymer testing 20, 2001, pp 217-221.
- [5] C. Maier, Polym. Eng. Sci. 36, p 1502, 1996.
- [6] I. Sbarski, E. Kosior, S.N. Bhattacharya, Int. Polym. Proc. 12, 1997, p 341.
- [7] Holton E. Harris, Extrusion Control, Hanser Gardner Publications. 2004.