

Turning Thin-Walled Workpieces with Variable Depth of Cut

M. Sadilek, L. Petrkovska, J. Kratochvil

Abstract—The article deals with the possibilities of increasing the efficiency of turning thin-walled workpieces. It proposes a new strategy for turning and it proposes new implementation of roughing cycles where a variable depth of cut is applied. Proposed roughing cycles are created in the CAD/CAM system. These roughing cycles are described in relation to their further use in practice.

The experimental research has focused on monitoring the durability of cutting tool and increases its tool life. It compares the turning where the standard roughing cycle is used and the turning where the proposed roughing cycle with variable depth of cut is applied. In article are monitored tool wear during cutting with the sintered carbide cutting edge. The result verifies theoretical prerequisites of tool wear.

Keywords—Variable depth of cut, CAD-CAM system, turning, durability.

I. ROUGHING TOOL PATH IN CAM SYSTEMS

CAD/CAM systems produce the technological basis for computer-controlled production. For standard programming of rough turning tool paths is commonly used online programming SFP - Shop Floor Programming. For specific programming of tool paths (non-linear tool path and cycles that are not in cycles at the workshop) it is appropriate to use CAM systems [1], [2].

The conventional roughing cycles in turning, where a cutting tool performs constant depth of cut can be adapted and extended with the cycles when the tool cuts with variable depth of cut. The proposed roughing cycles are as follows:

- Tool path “decreasing of engagement”, see Fig. 2.
- Tool path with creating conic surface, see Fig. 3.
- Tool path with the use of nonlinear methods, etc., see Fig. 4.

Figs. 1-4 depict a commonly used roughing cycle. In the Fig. 1 is possible to see a constant depth of cut is used in this roughing cycle. The machining process results in wear that prevails in one point of the cutting edge only.

During the roughing strategy – cut decrement, each chip removal is performed with a different depth of cut so a different cutting part of the tool is under stress during each cutting operation. This method of machining can be time consuming due to more passes. This is compensated for by

M. Sadilek is with the Technical University of Ostrava, Ostrava, 708 33 Czech Republic (corresponding author to provide phone: +420 605 239 835; fax: +420 59 691 6490; e-mail: marek.sadilek@vsb.cz).

L. Petrkovská and J. Kratochvil are with the Technical University of Ostrava, Ostrava, 708 33 Czech Republic. (e-mail: lenka.petrkovska@vsb.cz, jiri.kratochvil@vsb.cz).

increased tool life, lower loading of the machine spindle and reduced machine noise. This type of roughing cycle is already contained in the advanced CAM systems (Edge CAM, turning to profile).

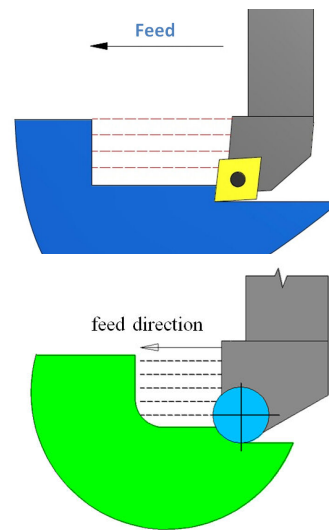

Fig. 1 Tool path with constant depth of cut with two types of insert

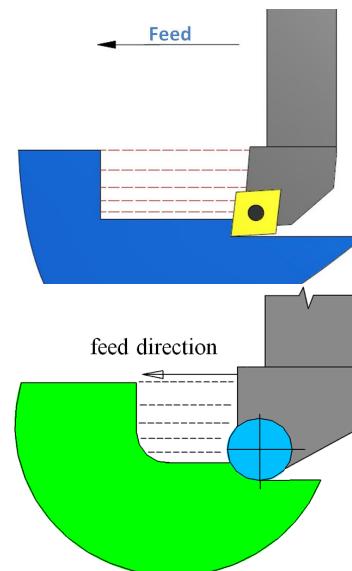

Fig. 2 Tool paths - decreased cut with two types of insert

Fig. 3 shows the cutting where a conical surface is formed starts with the deepest depth of cut which decreases in the

feeding direction. The second cut is programmed to be parallel with the workpiece axis. This provides for efficient removal of the conical surface formed in the previous cut. Thanks to this strategy, the tool wear moves along the cutting edge from the maximum to minimum depth of cut (a_{pmax} to a_{pmin}).

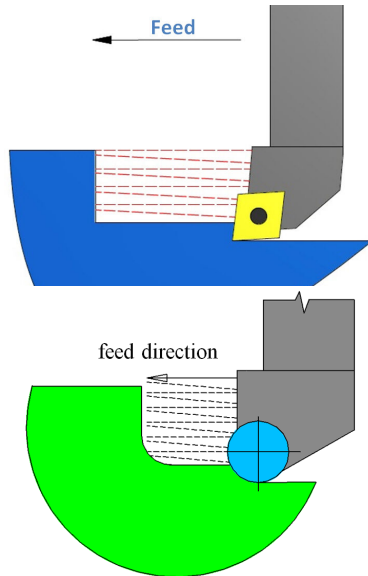

Fig. 3 Tool paths creating a conic surface (ramping) with two types of insert

In Fig. 4 is possible to see the non-linear roughing cycle method also ensures the variable depth of cut. For example, the tool path's wavy profile will achieve the same effect as the previous methods. Both in the first cut and the second cut, the machined material is on gradual increase and decrease and a variable depth of cut is thereby achieved.

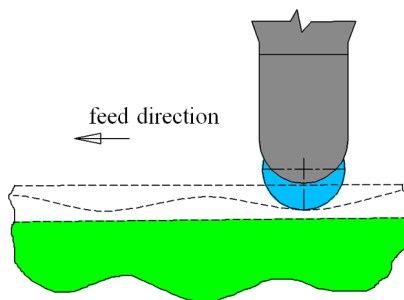

Fig. 4 Tool paths - nonlinear method

II. TOOL WEAR DURING VARIABLE DEPTH OF CUT

The most used cutting materials in the area of CNC machining are sintered carbide [3]-[5]. As seen in Fig. 5, the tool wear method depends on the applied tool materials. Tool wear will therefore grow with raising depth of cut [4], [6], [7].

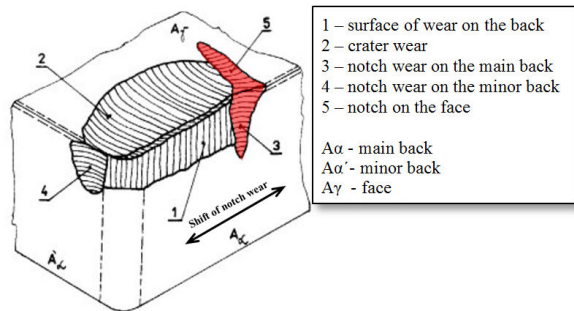

Fig. 5 Wear process of sintered carbide [5], [4], [1]

Sintered carbide tends to form a pronounced notch on the face and main back. This notch could be very advantageously used in the roughing cycles with variable depth of cut. Effort will be made to distribute this pronounced notch over the maximum possible length of the tool's cutting edge.

In applying the variable depth of cut (in the sintered carbide) the durability improvement effect is expected in the cutting edge provided the wear shaped as the notch on the back is distributed over the longer part of the cutting edge. These prerequisites were verified by the experiments under the practical machining of a part – flange.

III. EXPERIMENTAL WORK

Two strategies were used during turning: conventional method with constant depth of cut and cone-forming machining.

Verification of the theoretical presumptions was on a practical part. To this experiment was used:

- Cutting machine: Mori Seiki SL – 65 B with driving system Fanuc,
- Spindle power $P = 71$ kW,
- The workpiece material: austenitic stainless steel 1.4401 (DIN X5CrNiMo17-2-2), hardness 180 HB,
- Size of workpiece (flange): external diameter $\varnothing D = 350$ mm, internal diameter $\varnothing d_1 = 56$ mm, length $L = 73$ mm, internal diameter of semi product before finishing $\varnothing d_2 = 157$ mm,
- Cutting tool was internal radial turning tool (company Sandvik) with cutting inserts: CNMG 12 04 12 - MR 2025 with CVD coating.
- During cutting was used cutting fluid.

The cutting conditions differed only in the cut size and depth shape, see Fig. 6.

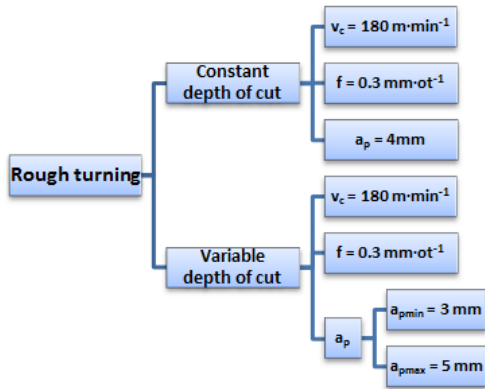

Fig. 6 Cutting conditions, where: v_c – cutting speed; f – feed; a_p – depth of cut

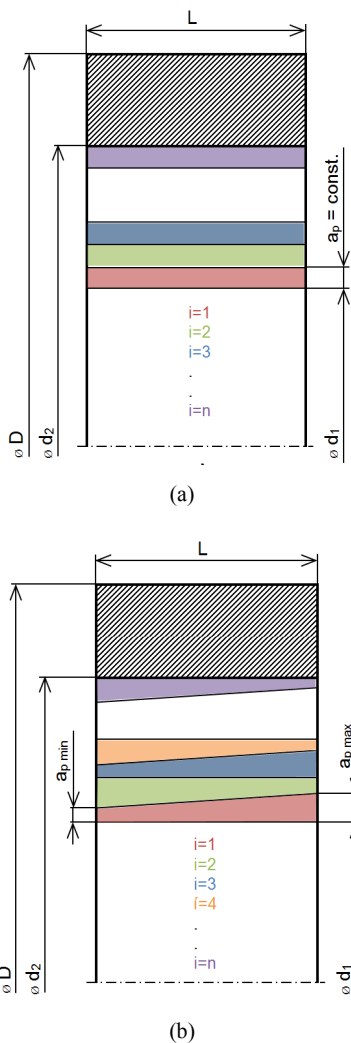

Fig. 7 Tool paths (a) constant depth of cut (b) variable depth of cut (i = from 1 to n , L = number of tool paths, n = total number of tool paths, L , $\varnothing D$, $\varnothing d_1$, = dimension of workpiece, L , $\varnothing D$, $\varnothing d_2$ = dimension of semi product before finishing)

In Fig. 8 is possible to see the different depths of cut (stock removals) in the internal roughing cycle. Here is shown a gradual removal of material from first tool path to the last (n^{th}). Total number of tool paths (n) depends on the size of the workpiece and technological possibilities of insert as well.

There is shown the simulation of machining (programmed tool path) when turning the flanges for which the experimental part was done.

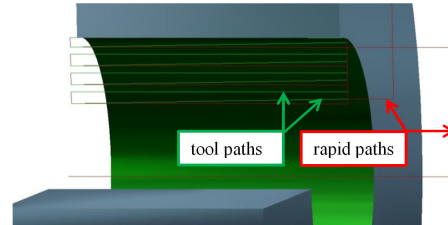

Fig. 8 Roughing cycle simulation when a conical surface is made during internal turning

A representative sample of tool wear has been selected from all the performed experiments that focus on the wear in the form of a notch on the face and on the back. For the measurement of a tool wear was used a microscope with an installed digital camera.

With variable depth of cut, the notches are distributed over the tool's longer cutting edge corresponding to the variable depth of cut. Notches shift in relation to the changing depth of cut (from 3mm to 5mm depth of cut), $x_{\text{variable}} = 1.49\text{mm}$.

Dependence of tool wear on time was recorded and entered into the "Dependence of VB_N tool wear on time" chart, see Fig. 9. Cutting process was interrupted in order to measure the tool wear after the tool path (between cuts) so as not to disturb the cutting process by start-up of the cut and getting out of the cut and it was kept interval of measuring - approximately 2 minutes. Measurements based on the standard ISO 3685:1993 [8]-[10].

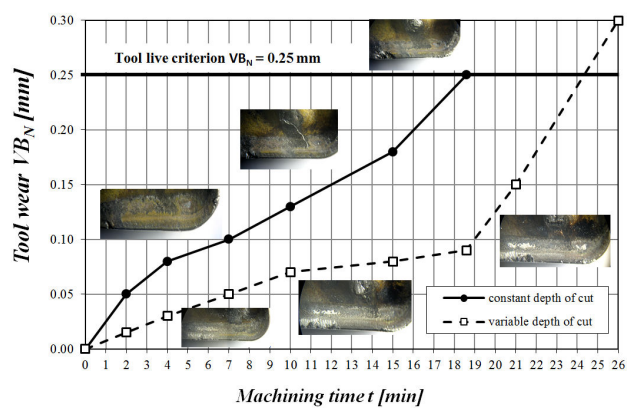

Fig. 9 Dependence of VB_N tool wear on time in the roughing strategy – constant depth of cut and variable depth of cut

This chart clearly implies that the choice of roughing

method where variable depth of cut is used shows lower wear VB_N in the same time and under the same cutting conditions. The wear has slighter inclination in the second area of tool wear. (i.e. II. area of tool wear names uniformly increased wear). Tool wear criterion was set at $VB_N = 0.25\text{mm}$.

The durability of cutting edge was 18min on average in the roughing cycle with constant depth of cut. In the newly designed cycle with variable depth of cut, the durability cutting edge was 26min, i.e. the durability increased by 44%.

IV. PRACTICAL APPLICATIONS

Research practical application was made in John Crane Company and in the Unex Company in the Czech Republic. The experimental work was made in the John Crane company. The Unex Company used rough cycle for rough turning of drive axle from semifinished product – cast, see in Fig. 10. For the production was used cutting machine SUT200/6000 CNC with driving system Fanuc.

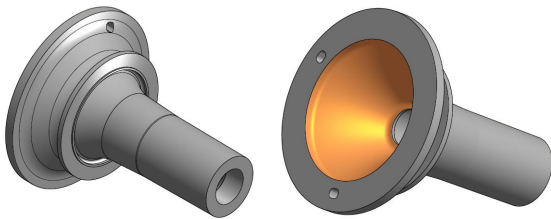

Fig. 10 Model of drive axle with marked surface for rough cycle (material 42 2139)

The following Figs. 11 and 12 describe the original rough cycle with a constant depth of cut a_p . In the figures is possible to see a length of approaching before casting shape, allowance for finish and length of start-up into the cut.

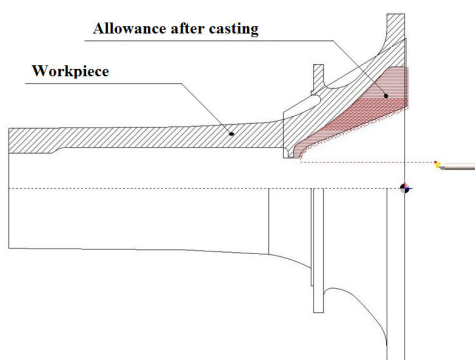

Fig. 11 Scheme of rough cycle with constant depth of cut a_p – drive axles

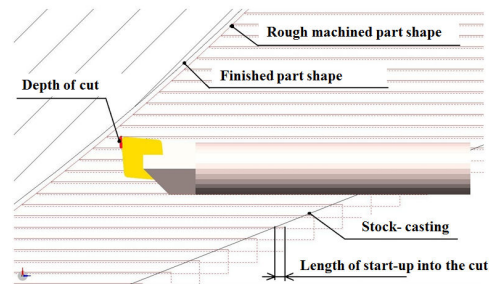

Fig. 12 Detail of rough cycle with constant depth of cut a_p – drive axles

Fig. 13 shows, how was use the strategy of roughing into the cone. The chip starts on the deepest cut $a_{p\max} = 12\text{mm}$ and it decreases gradually in the direction of feed to value $a_{p\min} = 3\text{mm}$. The following chip starts in the opposite sense of the depth of cut. The last tool path aligns the inequality after roughing cycle and follows the shape of the part.

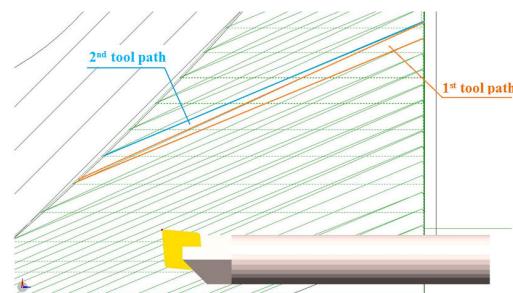

Fig. 13 Roughing cycle creating a conic surface – turning of drive axle

V. DISCUSSION AND CONCLUSIONS

The proposed manufacturing technology of the flange and shaft components ensures reduced tool wear, i.e. increased turning tool durability and life. This is a more favorable distribution of wear to the replaceable tool–insert while employing the proposed technology of turning.

The roughing cycle with variable depth of cut was applied in the company of John Crane a.s. It brought excellent results in the form of increased durability of the cutting edge by 44% in the maintained machine time.

Increased durability of the tool significantly reduces the total costs for cutting tools. These costs are also reduced by the less frequent downtimes when a worn tool is replaced. The disadvantage is more complicated tool path programming for the roughing cycle with variable depth of cut.

ACKNOWLEDGMENT

We would like to thank company JohnCrane a.s. for allowing us to perform our experiments. This paper was supported by the Czech Science Foundation, Student Grant Competition (SP2013/98), VSB-Technical University of Ostrava.

REFERENCES

- [1] Hatala, M. Simulation of technological process. 1th edit. Prešov : FVT TU, 2007, p. 85, ISBN 978-80-8073-756-6.
- [2] Svetlík, J.; Dobransky, J. Discourse about best choice CAD/CAM system. In: *New Trends in Technology System Operation*. Proceedings of the Seventh conference with international participation : Košice : Technická Univerzita, 2005. p. 90-92. ISBN 80-8073-382-1.
- [3] Sadílek, M.; Čep, R. Budak, I.; Sokovic, M. Aspects of Using Tool Axis Inclination Angle, *Strojníckí vestník - Journal of Mechanical Engineering*, 2011, vol. 57, no. 9, p. 681-688.
- [4] Čep, R.; Janásek, A.; Martinický B.; Sadílek M. Cutting tool life tests of ceramic inserts for car engine sleeves. *Tehnickí vjesnik/Technical Gazette*, 2011, No.2, Vol. 18, p. 203 – 209, 06/2011, ISSN: 1330-3651.
- [5] Forejt, M.; Humár A.; Piška, M.; Janíček, L. *Experimental methods – syllabus*. Brno. Brno University of Technology, Faculty of Mechanical Engineering, 2003, p. 83.
- [6] Neslušan, M.; Mrkvica, I.; Čep, R.; Kozak, D.; Konderla, R. Deformation After Heat Treatment and Their Influence on Cutting Process. *Tehnickí vjesnik/Technical Gazette*, 2011, Vol. 18, No. 4, p. 601-608. ISSN 1330-3651.
- [7] Mrkvica, I., Konderla, R., Faktor, M. Turning of Inconel 718 by Cemented Carbides. In MORGAN, M.M., SHAW, A., MGALOBILISHVILI, O. *Precision Machining VI. Key Engineering Materials*, 2012, vol. 496, p. 138-147. ISSN 1013-9826, ISBN 978-3-03785-297-2.
- [8] ISO 3685:1993. Tool-life testing with single-point turning tools, Geneva, International Organization for Standardization, 1993, 48 p.
- [9] Antic, A.; Petrovic, B.P.; Zeljkovic, M.; Kosec, B.; Hodolic, J. The influence of tool wear on the chip forming mechanism and tool vibrations. *Materiali in tehnologije/ Materials and technology*. 2012, Vol. 46, No. 3, p. 279-285, ISSN 1580-2949.
- [10] Čep, R.; Janásek, A.; Čepová, L.; Petřů, J.; Hlavatý, I.; Car, Z.; Hatala, M. Experimental testing of exchangeable cutting inserts cutting ability. *Tehnickí Vjestnik – Technical Gazette*, 2013. Vol. 20, No. 1, pp. 21-26. ISSN 1330-3651.

Sadílek M. is Associate Professor at the VŠB – Technical University of Ostrava (Czech Republic), Faculty of Mechanical Engineering, Department of Machining and Assembly. He graduated at the VŠB – Technical University of Ostrava with Doctor's degree in Engineering - PhD. in 2005 and he received his Assoc. Prof degree from VSB-TU in 2013. His research interest is mainly within CAD/CAM system in machining application and unconventional methods of machining. Most of the work is made in cooperation within industry.