

Triple-input Single-output Voltage-mode Multifunction Filter Using Only Two Current Conveyors

Mehmet Sagbas, Kemal Fidanboylu and M. Can Bayram

Abstract—A new voltage-mode triple-input single-output multifunction filter using only two current conveyors is presented. The proposed filter which possesses three inputs and single-output can generate all biquadratic filtering functions at the output terminal by selecting different input signal combinations. The validity of the proposed filter is verified through PSPICE simulations.

Keywords—Active Filters, Voltage mode, Current conveyor

I. INTRODUCTION

Voltage mode circuits using conventional operational amplifiers have the disadvantage of severely reduced bandwidth at higher gains because of the op-amp's fixed gain-bandwidth product. These disadvantages can be eliminated by using current conveyors [1-3].

Recently, many single and multi-output voltage mode universal biquadratic filters using current conveyors have been reported in the literature [4-10]. Some of these filters employ two positive-type second-generation current conveyors (CCII+) and one voltage follower [5, 9]. Some other filters employ one positive-type second-generation current conveyor, one negative-type second-generation current conveyor (CCII-), two capacitors and three resistors [6, 8]. Liu et al. reported a voltage-mode filter which employs one CCII+, one CCII-, two capacitors and three resistors [8]. Chang proposed a voltage-mode filter which employs three CCII+s, two capacitors and three resistors [4]. Later, Chang and Tu presented a voltage-mode filter which uses two CCII+, two capacitors and three resistors with orthogonal control over the natural frequency and the quality factor. However, this filter has four inputs and its transfer function is very complex [5]. Horng proposed a voltage-mode filter which employs three CCII+, two capacitors and two resistors [10].

In this paper, a new voltage-mode triple-input single-output multifunction filter using only two current conveyors is presented. The circuit uses one positive-type, one negative-

type second generation current conveyor, three resistors and two capacitors. The proposed filter can generate all second-order filtering functions of low-pass, high-pass, band-pass, notch and all-pass at the output terminal by selecting different input signal combinations. In the literature, there is only one voltage-mode multiple-input, single-output multifunction filter using two current conveyors [5]. However, this circuit has four inputs which results in a complex transfer function. Our proposed filter has only three inputs and has much simpler transfer function. The paper includes the analysis of the non-ideal effects of the proposed filter. It also includes sensitivity analysis and simulations using PSPICE.

II. CIRCUIT DESCRIPTION AND ANALYSIS

The ideal second generation current conveyor shown in Fig. 1 is described by the following relationship [11]:

$$I_y = 0, V_x = V_y, I_z = \pm I_x \quad (1)$$

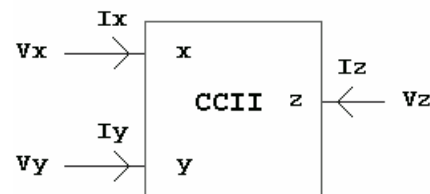

Fig. 1. Block diagram of the second generation current conveyor.

The input impedances for the ideal CCII+ are infinite at terminal y and zero at terminal x , respectively. The terminal z , that is equivalent to a current generator, possesses infinite output impedance.

Taking the non-idealities of the CCII into account, the above given terminal equation can be rewritten as

$$I_y = 0, V_x = \beta V_y, I_z = \pm \alpha I_x \quad (2)$$

where, $\beta = 1 - \varepsilon_v$ and $\alpha = 1 - \varepsilon_i$. ε_v ($|\varepsilon_v| \ll 1$) and ε_i ($|\varepsilon_i| \ll 1$) denote the voltage and current tracking errors,

Manuscript received February 15, 2005.

The authors are with the Electronics Engineering Department at Fatih University, Istanbul, Turkey (phone: +90-212-889-0810, fax: +90-212-889-0906, e-mail: kfidan@fatih.edu.tr).

respectively. In Eq. (1) and Eq. (2) the positive sign denotes a CCI+ and the negative sign denotes a CCI-.

The proposed multifunction filter which is illustrated in Fig. 2 employs only one positive-type second generation current conveyor, only one negative-type second generation current conveyor and five passive elements (two capacitors and three resistances). The transfer function of this circuit is given as follows:

$$V_o = \frac{s^2 R_1 R_2 R_3 C_1 C_2 V_1 + s R_2 R_3 C_2 V_2 + R_1 V_3}{s^2 R_1 R_2 R_3 C_1 C_2 + s R_2 R_3 C_2 + R_1} \quad (3)$$

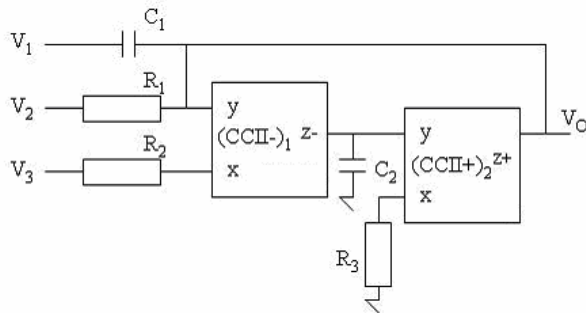

Fig. 2. Circuit diagram of the proposed voltage-mode triple-input single-output multifunction filter.

Arranging the numerator in Eq. (3) results in the following filter functions:

- (i) Grounding terminals V_1 and V_2 and applying input signal to terminal V_3 gives a second-order low-pass filter.
- (ii) Grounding terminals V_2 and V_3 and applying input signal to terminal V_1 gives a second-order high-pass filter.
- (iii) Grounding terminals V_1 and V_3 and applying input signal to terminal V_2 gives a second-order band-pass filter.
- (iv) Grounding terminal V_2 and applying input signal to terminals V_1 and V_3 gives a second-order band-reject filter.
- (v) Applying input signal to terminals V_1 , V_2 and V_3 such that $V_1 = V_3 = -V_2$ gives a second-order all-pass filter.

Thus, all the standard filter functions; high-pass, band-pass, low-pass, band-reject and all-pass can be obtained from the proposed filter.

The natural frequency and the quality factor of the proposed circuit can be obtained from the denominator polynomial of the transfer functions as follows:

$$\omega_o = \frac{1}{\sqrt{R_2 R_3 C_1 C_2}} \quad (4)$$

$$Q = \sqrt{\frac{C_1}{C_2 R_2 R_3}} R_1 \quad (5)$$

Taking the non-idealities of the positive-type and negative-type second generation current conveyors given in Eq. (2) into account, the denominator polynomial of the transfer functions for the proposed filter becomes

$$D(s) = s^2 R_1 R_2 R_3 C_1 C_2 + s R_2 R_3 C_2 + \alpha_1 \alpha_2 \beta_1 \beta_2 R_1 \quad (6)$$

Using Eq. (6), the natural frequency and the quality factor can be recalculated as

$$\omega_o = \sqrt{\frac{\alpha_1 \alpha_2 \beta_1 \beta_2}{R_2 R_3 C_1 C_2}} \quad (7)$$

$$Q = \sqrt{\frac{\alpha_1 \alpha_2 \beta_1 \beta_2 C_1}{C_2 R_2 R_3}} R_1 \quad (8)$$

Note that ω_o and Q are adjustable by R_1 and R_2 (or R_3) and BW is adjustable by R_1 .

III. SENSITIVITY ANALYSIS

The ideal sensitivities of the natural frequency and the quality factor with respect to passive components are calculated as follows:

$$S_{R_1}^{\omega} = 0 \quad (9)$$

$$S_{R_2}^{\omega} = S_{R_3}^{\omega} = S_{C_1}^{\omega} = S_{C_2}^{\omega} = -\frac{1}{2} \quad (10)$$

$$S_{R_1}^Q = 1 \quad (11)$$

$$S_{C_1}^Q = \frac{1}{2} \quad (12)$$

$$S_{R_2}^Q = S_{R_3}^Q = S_{C_2}^Q = -\frac{1}{2} \quad (13)$$

From the above calculations, it can be seen that all sensitivities are fairly small.

From Eq. (7) and (8), the non-ideal sensitivities can be found as follows:

$$S_{R_1}^{\omega} = 0 \quad (15)$$

$$S_{R_2}^{\omega} = S_{R_3}^{\omega} = S_{C_1}^{\omega} = S_{C_2}^{\omega} = -\frac{1}{2} \quad (16)$$

$$S_{\alpha_1}^{\omega} = S_{\alpha_2}^{\omega} = S_{\beta_1}^{\omega} = S_{\beta_2}^{\omega} = \frac{1}{2} \quad (17)$$

$$S_{R_1}^Q = 1 \quad (18)$$

$$S_{R_2}^Q = S_{R_3}^Q = S_{C_2}^Q = -\frac{1}{2} \quad (19)$$

$$S_{C_1}^Q = \frac{1}{2} \quad (20)$$

$$S_{\alpha_1}^Q = S_{\alpha_2}^Q = S_{\beta_1}^Q = S_{\beta_2}^Q = \frac{1}{2} \quad (21)$$

From the above relations, it can be seen that all sensitivities are also fairly small.

IV. SIMULATIONS AND RESULTS

The validity of the filter was tested using PSPICE. Bias currents and voltages of the positive-type and negative-type second generation current conveyor were taken as $I_1 = I_2 = 200 \mu F$, $V_{cc} = 5 V$ and $V_{ce} = -5 V$ respectively.

For these simulations the passive components were chosen as, $C_1 = C_2 = 1 nF$ and $R_1 = R_3 = 1 k\Omega$, $R_2 = 2 k\Omega$.

Using the above parameters, the simulation results for the second-order low-pass, high-pass, band-pass and band-reject filter responses are shown in Fig. 3 and all-pass filter response is shown in Fig. 4, respectively.

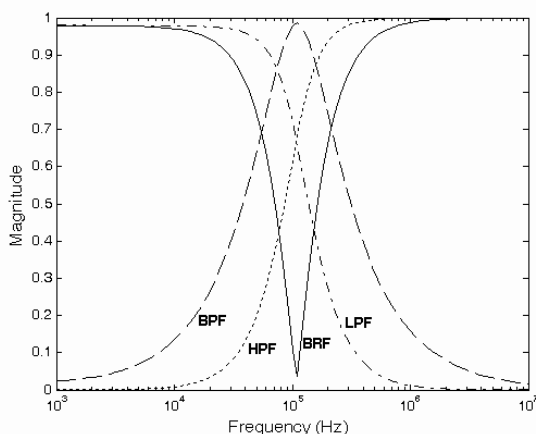

Fig. 3. PSPICE simulation results for the triple-input single-output voltage mode multifunction filter.

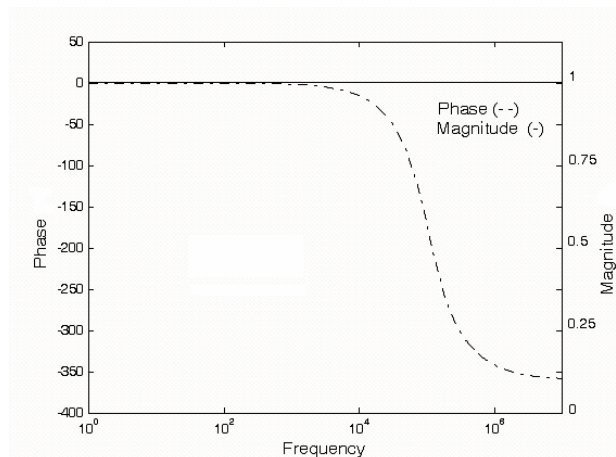

Fig. 4. PSPICE simulation results for the triple-input single-output voltage mode multifunction filter showing all-pass response.

V. CONCLUSION

We have presented a new voltage-mode triple-input single-output multifunction filter using only two current conveyors. The validity of the proposed filter has been demonstrated through PSPICE simulations. The proposed filter has the following advantages: (i) Use of only two current conveyors; (ii) Realization of all the basic filter functions: low-pass, high-pass, band-pass, notch and all-pass filter response from same configuration; (iii) Low passive and active sensitivities; (iv) Capability of adjusting ω_o and Q are adjustable through resistors and capacitors; (v) Orthogonal control over ω_o and Q .

REFERENCES

- [1] B. Wilson, "Recent developments in current mode circuits", *IEE Proc. Pt G*, 137, pp. 63-67, 1990.
- [2] U. Kumar and S. K. Shukla, "Recent developments in current conveyors and their applications", *IEE Proc. G.*, vol. 16, pp. 47-52, 1985.
- [3] D.C. Wandsworth, "Accurate current conveyor integrated circuits", *Electronics Letters*, vol. 25, no. 18, pp. 1251-1252, 1989.
- [4] C. M. Chang, "Universal active current filter with three inputs and one output using plus type CCII's", *Electronics Letters*, vol. 33, no. 14, pp. 1207-1208, 1997.
- [5] C. M. Chang and S. H. TU, "Universal voltage-mode filter with four inputs and one output using two CCH+s", *International Journal of Electronics*, vol. 86, no. 3, pp. 305-309, 1999.
- [6] J.W. Horng, C. G. Tsai, and M. H. Lee, "Novel universal voltage-mode biquad filter with three inputs and one output using only two current conveyors", *International Journal of Electronics*, vol. 80, pp. 543- 546, 1996.
- [7] J. W. Horng, M. H. Lee, H. C. Cheng, and C. W. Chang, "New CCII based voltage-mode universal biquadratic filter",

International Journal of Electronics, vol. 82, pp. 151-155, 1997.

[8] S. I. Liu, and J. L. Lee, "Voltage-mode universal filters using two current conveyors", *International Journal of Electronics*, vol. 82, pp. 145-149, 1997.

[9] S. Ozoguz and E. O. Gunes "Universal filter with three inputs using CCII", *Electronic Letters*, vol. 32, pp. 2134-2135, 1996.

[10] J. W. Horng, "High-input impedance voltage mode universal biquadratic filter using three plus type CCIIs", *IEEE Trans. on Circuits and Systems*, vol. 48, no. 10, pp. 996-997, 2001.

[11] K. C. Smith and A. Sedra, "A second generation current conveyor and its applications", *IEEE Trans. Circuit Theory*, vol. CT-17, pp. 132-134, 1970.