

Topographical Image Transference Compatibility Generated Through *Moiré* Technique Applying Parametrical Softwares of Computer Assisted Design

M. V. G. Silva, J. Gazzola, I. M. Dal Fabbro, and A. C. L. Lino

Abstract—Computer aided design accounts with the support of parametric software in the design of machine components as well as of any other pieces of interest. The complexities of the element under study sometimes offer certain difficulties to computer design, or even might generate mistakes in the final body conception. Reverse engineering techniques are based on the transformation of already conceived body images into a matrix of points which can be visualized by the design software. The literature exhibits several techniques to obtain machine components dimensional fields, as contact instrument (MMC), calipers and optical methods as laser scanner, holograms as well as *moiré* methods. The objective of this research work was to analyze the *moiré* technique as instrument of reverse engineering, applied to bodies of non complex geometry as simple solid figures, creating matrices of points. These matrices were forwarded to a parametric software named SolidWorks to generate the virtual object. Volume data obtained by mechanical means, i.e., by caliper, the volume obtained through the *moiré* method and the volume generated by the SolidWorks software were compared and found to be in close agreement. This research work suggests the application of phase shifting *moiré* methods as instrument of reverse engineering, serving also to support farm machinery element designs.

Keywords—Reverse engineering, *Moiré* technique, three dimensional image generation.

I. INTRODUCTION

REVERSE engineering is a specific field associated to mechanical projects in which the machine elements physical dimensions are forward to the CAD/CAM software to generate the three dimensional view of the components under study. In other words, reverse engineering (RE) is supported by the concept departing from a physical model without designing. It is necessary a tool to insert the object shape into the CAD system taking advantages of all possibilities offered

M. V. G. Silva is with the State University of Campinas, Campinas, SP, Brazil (corresponding author to provide phone 55-19-3521-1059; e-mail: margosgebra@terra.com.br).

J. Gazzola is with the State University of Campinas, Campinas, SP, Brazil (corresponding author to provide phone 55-19-3521-1059; e-mail: jonathan_gazzola@yahoo.com.br).

I. M. Dal Fabbro is with the State University of Campinas, Campinas, SP, Brazil (corresponding author to provide phone 55-19-3521-1059; e-mail: inacio@feagri.unicamp.br).

A.C.L.Lino is with the Agronomical Institute of Campinas, Jundiaí, SP, Brazil (corresponding author to provide phone 55-11-4582-8155; e-mail: lino@iac.sp.gov.br).

by the software [2]. Generally speaking, RE techniques are based in capturing objects three dimensions and recreate that image by means of CAD tools, permitting improvements, cost reduction, inclusion of new characteristics, etc. It can also be applied in producing replacement components to keep working equipment already considered obsolete [1]. RE process is divided into phases, as (1) product digitalization and (2) creation of the CAD model from the digitalized image [3].

The points of the body surface can be captured by physical contact by means of probes or through optical means or light sensors which project the beam onto the object surface, as laser scanners and photogrammetry [3].

Three dimensional scanners are composed of sensors of high definition which are uncharged of capturing the 3D coordinates, point by point overall the object surface following by the transference to a CAD station. The sensors employed in 3D scanners can be classified into several types as follows. (1) Feelers, (2) white light optical sensors, (3) and (4) magnetic waves sensors [6].

Photogrammetry consists in projecting optical grids onto the object surface for further digitalization [3].

Moiré methods are optical technique able to determine the topography of regular or irregular surfaces. The phenomenon can be observed when two optical grids move one with relation to each other, generating patterns which are similar to waves, known as *moiré* fringes as it is displayed on Figure 1.

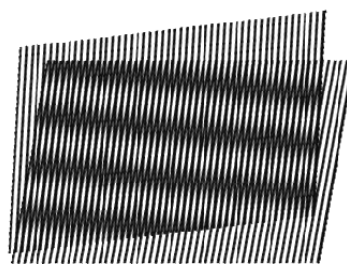

Fig. 1 Example of *Moiré* Frinjes

Phase shifting *Moiré* is a very popular technique which is based on 03 or 04 images with small fringe displacement to generate phase map and consequently the object contour. Grids are displaced by 0π , $1/3\pi$ and $2/3\pi$ or, in the second case by $e 0\pi$, $1/4\pi$, $1/2\pi$ and $3/4\pi$ in the second case (Figure 2) [10]-[11].

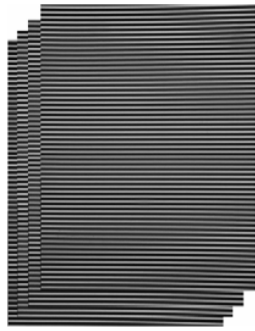

Fig. 2 Out of Phase by $\pi/2$ Grids.

The application of a computational program (Rising Sun *Moiré*) to obtain the wrapped phase maps followed by the unwrapping procedure [4]. A specific algorithm for the MATLAB software to calculate the phases as well as the unwrapping step, by summing or by subtracting the value of π following neighboring pixel comparison, which can be respectively negative or positive was developed by [7]–[8]. Four fringe images are necessary in which one the object gets closer or further to the reference grid, generating fringes displacement of $1/2\pi$, 1π and $3/2\pi$ of phase. If 04 images displaced by $\pi/2$ on from each other are used, light intensities are described by Equation 1, Equation 2, Equation 3 and Equation 4 [9].

$$I_1(x, y) = a(x, y) - b(x, y)\cos\phi(x, y) \quad (1)$$

$$I_2(x, y) = a(x, y) - b(x, y)\cos[\pi/2 + \phi(x, y)] \quad (2)$$

$$I_3(x, y) = a(x, y) - b(x, y)\cos[\pi + \phi(x, y)] \quad (3)$$

$$I_4(x, y) = a(x, y) - b(x, y)\cos[3\pi/2 + \phi(x, y)] \quad (4)$$

Where $a(x, y)$ stands for light intensity of the background of each image point, $b(x, y)$ is the modulated intensity of each point of the image, ϕ is the phase to be determined. The solution of the 04 simultaneous equations to obtain the phase term ($\cos\phi$) associated to each point of the image as represented by Equation 5, Equation 6 and Equation 7 [5].

$$\phi(x, y) = \arctan\left[\frac{(I_4(x, y)) - (I_2(x, y))}{(I_1(x, y)) - (I_3(x, y))}\right] \quad (5)$$

$$\phi(x, y) = \arctan\left[\frac{(I_3(x, y)) - (I_1(x, y))}{(I_4(x, y)) - (I_2(x, y))}\right] \quad (6)$$

$$\phi(x, y) = \arctan\left[\frac{2(I_2(x, y)) - (I_4(x, y))}{2(I_3(x, y)) - (I_1(x, y)) - (I_5(x, y))}\right] \quad (7)$$

Some advantages of that method as precision, rapidity and reliability despite of low fringes contrast are related by [5].

This research work aims to apply the phase shifting *moiré* technique as a tool for reverse engineering. That way, bodies

of simple geometry had their dimensions digitalized to compare the volume values obtained through other techniques, as Contacting Measuring Instruments (CMI), calipers or micrometers as well as immersion method.

The results are expected to permit a quantitative analysis in terms of volume of the reliability of the phase-shifting *moiré*, associated to CAD software.

II. MATERIALS AND METHODS

Moiré experimental set include a Core 2 Duo, 2,2GHz with 1 GB Ram memory coupled to a NEC, VT 560 exhibiting a resolution of 1024 columns and 768 lines LCD projector and to a SAMSUNG, SDC 312, 640 columns by 480 lines CCD camera coupled to an DT313 Data Translation image capturing board. Image capturing and processing involved the software Global Lab Image2 – Data Translation. Four cylinders were used to measure their volumes. Specimens were previously painted with white opaque color to improve contrast. Sinusoidal as well as Ronchi grid with two frequencies of 100 lines/mm and 200 lines/mm projected with a distance of 1m from the of the light source, varying 90° one from each other, up to the total of 360° .

The four obtained *moiré* fringe images were named (I_1 , I_2 , I_3 and I_4). Between each one of them the grid was displaced in the Z direction toward the reference grid, producing the displacements in the *moiré* fringes of 0 , $1/4\pi$, $1/2\pi$ and $3/4\pi$. Resulting images indicate an inversion between images I_1 and I_3 and between I_2 and I_4 , i.e. fringe colors are alternated from white to dark color. Photo Edition software was applied for grids removal as well as for equalization.

From the above described images the RISING-SUN *MOIRÉ* software generated the phase map as described by the Equations 01,02,03 and 04 as mentioned by [9]. The phase unwrapping procedure finally generated the cylinder images. That model is represented by a RASTER image which varies from 0 to 255 , i.e., 256 color levels or gray level which corresponds to Z values.

The X and Y point coordinates were separated in a TXT archive the Notepad software. Each point layer point data represented by a coordinate Z was separated in a different archive. The first line of coordinates of each layer was replicated at the last line to force the perimeter closure.

The TXT archive was opened in the SOLIDWORKS software through the *curves command* for each layer of data points. The X, Y plane was manually shifted according to the Z values. The *Loft command* was called to connect the points between layers to generate the final solid shape. The *Mass Property* (SolidWorks) command will generate the solid volume.

For validation and comparison of results obtained through *moiré* methods, specimens used on test had their results volume measured by other conventional methods. In this research work were applied the Caliper, the Contacting Measuring Instruments (CMI) and the Fluid Immersion as conventional system of volume measurement.

III. RESULTS AND DISCUSSIONS

Figure 3 and Figure 4 show an example of coordinate transference process of the points to the SolidWorks software in curve formats. Figure 5 shows the transformation from curves to the solid by means of the *Loft command*. From Figure 3 it is noted that each layer of the **Z** axis as obtained by the *moiré* method was transformed into points of bidimensional coordinates (X,Y). Coordinate transformation through the *Loft command* of the coordinates to the geometric solid had the line selected close to the perpendicular, avoiding distortion propagation on the solid figure.

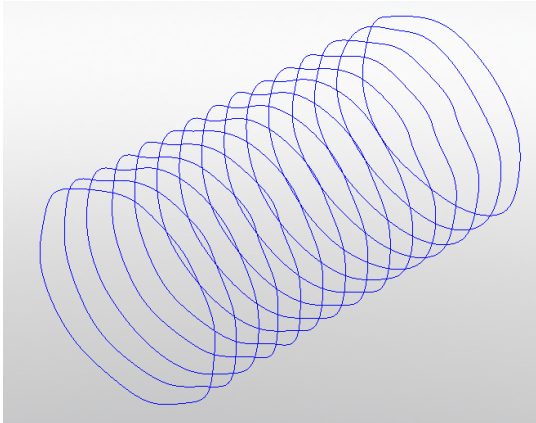

Fig. 3 Coordinate transference of points to the Solid Works software to curve format.

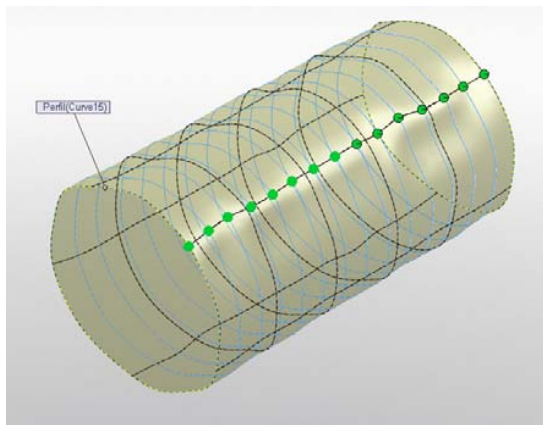

Fig. 4 Transformation of curves to solid figure by means of the Loft command.

Figure 5 to 8 show results of solids obtained through SolidWorks software for each replication test.

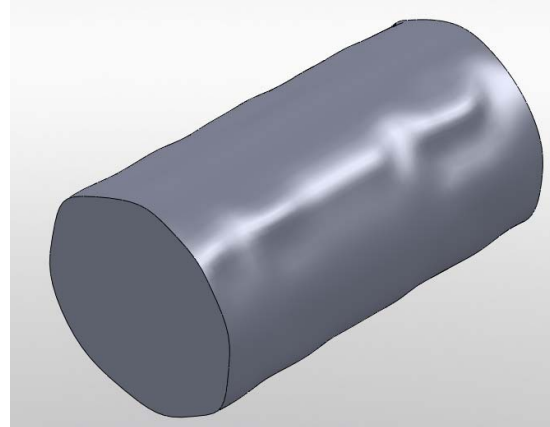

Fig. 5 Geometric solid generate by the Solidwoks software with coordinate data obtained through the Phase-Shifting technique replication specimen cylinder C_1 .

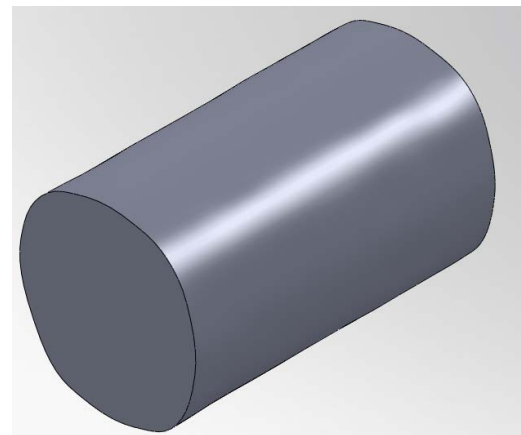

Fig. 6 Geometric solid generate by the Solidwoks software with coordinate data obtained through the Phase-Shifting technique replication specimen cylinder C_2 .

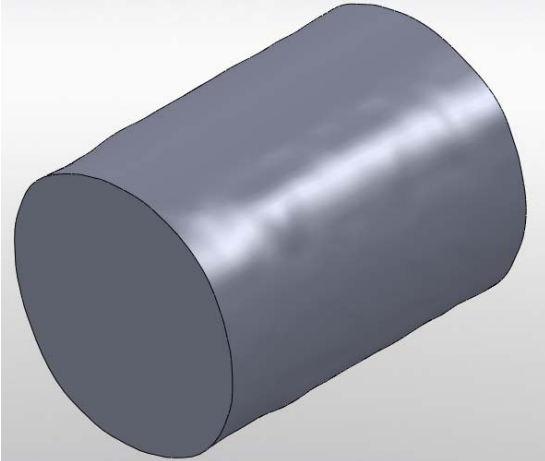

Fig. 7. Geometric solid generate by the Solidwoks software with coordinate data obtained through the Phase-Shifting technique replication specimen cylinder C_3 .

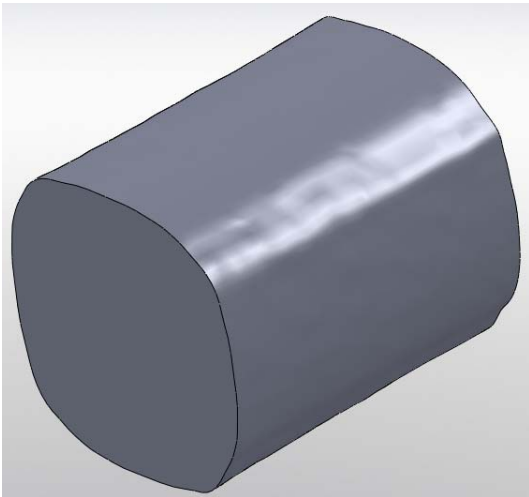

Fig. 8. Geometric solid generate by the Solidwoks software with coordinate data obtained through the Phase-Shifting technique replication specimen cylinder C_4 .

It can be noticed from Figure 5 to 8 that *moiré* technique generated the 3D coordinates even emphasizing the imperfections on the cylinders surfaces. Cylinder C_1 present higher imperfections level if compared with cylinder C_2 . Cylinder C_4 presented less cylindrical shape when compared with the others. Table I shows volume data as obtained by conventional measuring methods, including standard deviation values. Table II shows volume data obtained by the *moiré* technique associated to the SolidWorks program with comparisons of average volumes. Table III shows dimension variation following the ISO 15530.

TABLE I
CYLINDER VOLUMES OBTAINED BY CONVENTIONAL METHODS

Test	Caliper [mm ³]	Fluid Immersion [mm ³]	MCI
C_1	86.408,09	86.000	86.408,09
C_2	110.622,03	115.000	110.622,03
C_3	187.301,1	189.000	187.301,10
C_4	233.204,39	241.000	233.204,39

TABLE II
CYLINDER VOLUMES OBTAINED BY MOIRÉ METHOD AND STATISTICAL DATA

Test	Solid Works [mm ³]	Average Volume [mm ³]	Standard Deviation (%)
C_1	86.293,04	86.272,06	0,02
C_2	108.691,79	112.081,35	2,20
C_3	192.786,83	187.867,40	1,80
C_4	245.329,2	235.802,93	2,74

TABLE III
ISO 15530 TABLE OF SIMILARITY

Parameter	ALLOWED REQUIREMENTS	
Geometric Characteristics	Dimensions	- Over 250 mm: up to 10% of variation - Less than 250 mm: 25 mm of variation
	Angles	Up to 5% of variation

Some authors present studies related to measurement obtained by conventional methods together with their degree of precision. Arenhart (2.007) states that coordinates measured by contact methods (CMI) can vary from 1 to 9% according to desired precision. Silva et al. (2.011) presented variations for volume calculation of objects of simple geometry obtained by caliper generating errors 5,47% of the average volume.

Cylinders volume values obtained by *moiré* presented a standard deviation lower than 3% which can be considered satisfactory because the maximum acceptable value is of 5%. These standard deviations are also lower if compared with conventional methods of volume determination. It should be emphasized that geometric data dispersion viability is the tolerance degree required by the element.

If the period of the projected Ronchi grid is increased, the measurement precision will also increase. However, period increase requires equipment with higher resolution for image capture. A major advantage associated to application of the proposed method refers to low cost if the technique meets the required tolerance.

IV. CONCLUSION

Based on the results presented above leads to the conclusion that the association of the SolidWorks software with the *moiré* methods is adequate to reproduce the three dimensions of objects of simple geometry. Further tests should treat the space dimensions of objects with complex geometry.

ACKNOWLEDGMENT

M, V. G. Silva and A. C. L. Lino thanks to Agronomical Institute of Campinas for technical support to this research work. J. Gazzola thanks to FEAGRI/Unicamp and CNPq for sponsor and financial support to this research work.

REFERENCES

- [1] L. B. Alves, C. E. Sanches da Silva, C. H. P. Mello. Analysis of the use of the technology roadmapping as a means of selecting a reference product for reverse engineering. *Gest. Prod. Journal*. São Carlos, v. 18, pp. 55-72, 2.011.
- [2] A. B. Ferneda, et al. Metrology, CAD and CAM integration: a contribution to reverse engineering study. São Carlos, 112 p. 2.011.
- [3] Jardim, et. al. Integração de prototipagem rápida e engenharia reversa no desenvolvimento rápido de produto. Proceedings of 6^o COBEF, Caxias do Sul, RS, Brazil, 11 p. 2.011.
- [4] A.C.L. Lino. Técnica óptica de *moiré* visando a aplicação no estudo de superfícies irregulares. Campinas, 86 p. 2.002.
- [5] A. C. L. Lino, J. Sanches, I. M. Dal Fabbro. Image processing techniques for lemons and tomatoes classification. *Bragantia*, Campinas, v.67, n.3, p.785-789, 2008.
- [6] L. G. M. Mury. A methodology to adaptation and improvement of products conceived through reverse engineering. Porto Alegre, 100 p. 2.000.
- [7] P. Smith neto, E. A. Fonseca, G. H. F. Freitas. Application of Digital Shadow *Moiré* to Measurements of Human Body Perfilometry. In: 5th International Conference on Mechanics and Materials in Design, 2006, Porto. Mechanics and Materials in Design. Leça do Balio, Portugal : INEGI-Instituto de Engenharia Mecânica e Gestão Industrial, 2006. v. 1. p. 63-71.
- [8] P. Smith neto, P. A. A. Magalhães junior. Determination of human body profile using digital shadow *moiré* experimental technique. In: Iberian Latin America Congress on Computational Methods in Engineering -27 CILAMCE, 2006, Belém-Pará. CILAMCE2006. Belém, Pará : Universidade Federal do Pará, 2006.
- [9] Y. Wang. Shadow *Moiré* sensitivity increase by fringe shifting: phase-stepping. <<http://www.warpfinder.com/phase.html>>, 03/09/2007.
- [10] Z. Zhang, C. E. Towers, D. P. Towers. Phase and colour calculation in colour fringe projection. *J. Opt. A: Pure Appl. Opt.* v. 9, S81-S86, 2007.
- [11] Z. Zhang, C. E. Towers, D. P. Towers. Time efficient color fringe projection system for 3D shape and color using optimum 3-frequency Selection. *Optics Express*. v. 14, v. 14, p. 6444-6455, Julho, 2006.