

Three-Level Converters Back-to-Back DC Bus Control for Torque Ripple Reduction of Induction Motor

T. Abdelkrim, K. Benamrane, B. Bezza, Aeh Benkhelifa, A. Borni

Abstract—This paper proposes a regulation method of back-to-back connected three-level converters in order to reduce the torque ripple in induction motor. First part is dedicated to the presentation of the feedback control of three-level PWM rectifier. In the second part, three-level NPC voltage source inverter balancing DC bus algorithm is presented. A theoretical analysis with a complete simulation of the system is presented to prove the excellent performance of the proposed technique.

Keywords—Back-to-back connection, Feedback control, Neutral-point balance, Three-level converter, Torque ripple.

I. INTRODUCTION

THE use of PWM technique at low level voltage converters back-to-back connected is the main cause of torque ripple in induction motor. The effects of torque ripple are particularly undesirable in some demanding motion control and machine tool applications. They lead to speed oscillations which cause deterioration in the performance. In addition, the torque ripple may excite resonances in the mechanical portion of the drive system, produce acoustic noise, and, in machine tool applications, leave visible patterns in high-precision machined surfaces [1].

The use of conventional two-level inverter for high power induction motors driven cannot accomplish satisfactory torque ripple reduction compared to three-level inverter [2]. Multilevel voltage source converters are emerging as a new breed of power converter options for high-power applications. These converters typically synthesize the staircase voltage wave from several levels of DC capacitor voltages [3]. Different topologies has been developed like diode-clamped inverter (neutral-point clamped), capacitor-clamped (flying capacitor), and cascaded multicell with separate DC sources [4].

One of the major limitations of the multilevel converters is the voltage unbalance between different levels. The techniques to balance the voltage between different levels normally involve voltage clamping or capacitor charge control. There are several ways of implementing voltage balance in multilevel converters [3].

This paper investigates the use of a back-to-back connection of three-level converters (Fig. 1). This connection allow balancing of the DC link capacitor voltages under a full range of operating conditions [5] whereas, only a limited operating

range is possible if a passive rectifier (diode bridge) is employed [6]. Additional advantages brought by the back-to-back connection have been shown to include: the ability to draw almost sinusoidal currents from the supply, the input power factor can be controlled and the back-to-back topology automatically regenerates power back to the supply when the operating conditions dictate [7]. Alternatively, a passive rectifier draws a pulsed current from the supply and does not allow a regenerative current to return to the supply.

In this paper, first part is dedicated to the presentation of three phases three-level PWM current rectifier regulation loop. After that the DC bus voltages balancing using the redundant positive and negative small vectors of three-level NPC inverter is detailed. At the end the simulation results demonstrate efficacy of this of back-to-back three-level converters DC bus control.

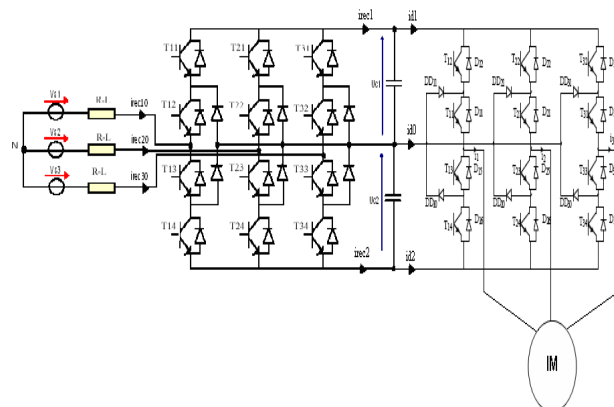

Fig. 1 Back-to-back three-level converters-Induction motor

II. THREE-LEVEL CONVERTERS BACK-TO-BACK DC BUS CONTROL

A. Three-Level Rectifier Control

In this part, one proposes to enslave the output DC voltage of three-level PWM current rectifier using a PI-based feedback control. The synoptic diagram of three-level PWM current rectifier control is shown in Fig. 2 [8]-[10]. The transfer functions $G_r(S)$ and $G_v(S)$ are expressed as follows:

$$G_r(S) = \frac{(1/R_r)}{1 + (L_r/R_r)S} \quad (1)$$

$$G_v(S) = \frac{1}{CS} \quad (2)$$

T. Abdelkrim, K. Benamrane, B. Bezza, Aeh Benkhelifa, A. Borni are with Unité de Recherche Appliquée en Energies Renouvelables, URAER, Centre de Développement des Energies Renouvelables, CDER, 47133, Ghardaïa, Algeria (e-mail: tameur2@yahoo.fr).

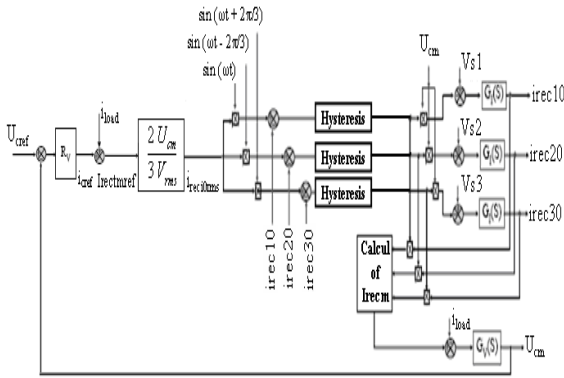

Fig. 2 Synoptic diagram of three-level PWM current rectifier control

The modeling of this loop is based on the instantaneous power conservation principle with no loss hypothesis. This loop imposes the root mean square (rms) value of network current.

Input and output powers are:

$$\begin{cases} P_{in} = \sum_{i=1}^3 (V_{si} i_{reci0} - R_r i_{reci0}^2 - \frac{L_r}{2} \frac{di_{reci0}^2}{dt}) \\ P_{out} = \sum_{i=1}^2 (U_{ci} i_{reci}) = 2U_{cm} (i_c + i_{load}) \end{cases} \quad (3)$$

Different quantities i_{load} , i_c , I_{rectm} (Fig. 2) are defined as follows:

$$\begin{cases} I_{rectm} = \frac{i_{rec1} - i_{rec2}}{2} \\ i_{load} = \frac{id1 - id2}{2} \\ i_c = I_{rectm} - i_{load} \end{cases} \quad (4)$$

Using of the power conservation principle and neglecting of joules loss in the resistor R_r , and considering a sinusoidal supply network current in phase with corresponding voltage V_{si} , it can be written:

$$3 V_{si} i_{reci0} = 2 U_{cm} (i_c + i_{load}) \quad (5)$$

B. Three-Level NPC Inverter Control

In the space vector diagram of three-level inverter (Fig. 3), we can distinguish four types of vectors: large vectors, medium vectors, small vectors and zero vectors [11].

The large vectors are the vectors that all of three legs are connected to either point P or N, except in the case of all the three being connected at the same point. There are six large vectors in the space vector diagram: PNN, PPN, NPN, NPP, NNP and PNP. The medium vectors are the ones that only one phase is connected to point O and other two phases are connected to P and N each other. There are six medium vectors: PON, OPN, NPO, NOP, ONP and PNO. The small vectors are those vectors that have two phases connected at the same point. There are twelve of them: PPO, OON, OPO,

NON, OPP, NOO, OOP, NNO, POP, ONO, POO and ONN. The zero vectors are the vectors that have all three phases are connected at the same point. There are three zero vectors: PPP, OOO and NNN.

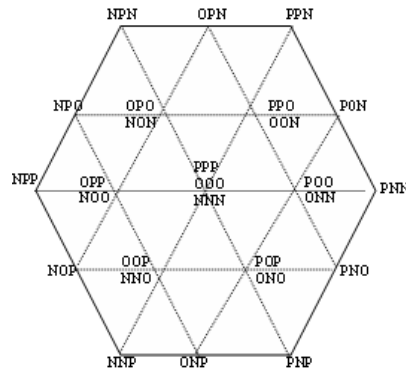

Fig. 3 Space vector diagram of a three-level inverter

To show the effect of each type of vectors on the neutral point potential, we present the load connections of one example of each type in Fig. 4. It may be easily deduced from Figs. 4 a. and d. that neither zero vectors nor large vectors inject current in the neutral point O. So they do not change the voltage of neutral point.

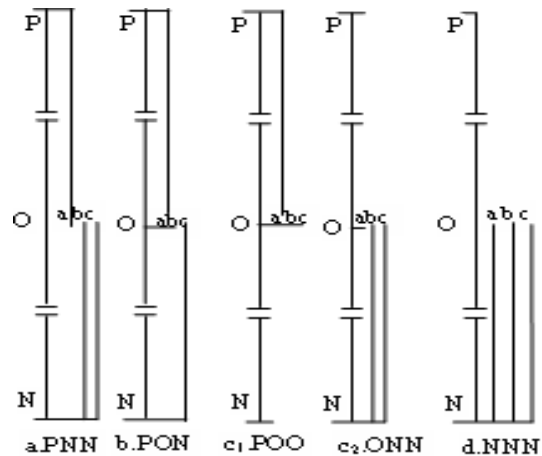

Fig. 4 Neutral point connections

Fig. 4 b. shows that medium vectors can inject current in the neutral point. Figs. 4 c1. and c2. show two small vectors with two different switching combinations: POO and ONN. These two vectors product the same output voltage, but when the vector POO is applied, the current flows into the neutral point ($i_{d0} = -i_1$), while with the vector ONN, the current flows out ($i_{d0} = i_1$) (Fig. 5).

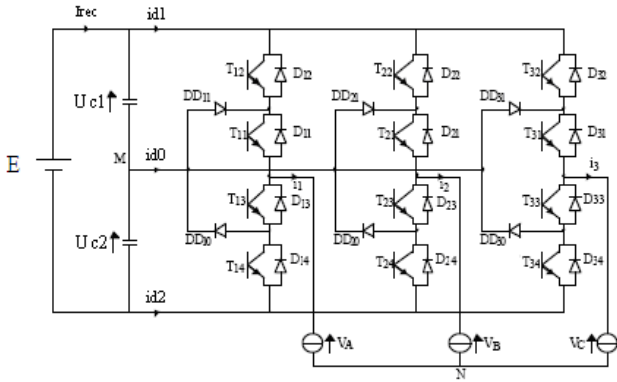

Fig. 5 Three-level NPC voltage source inverter

Table I shows the current injected by all small and medium vectors [12]. As we see, each small redundant vector can inject either positive or negative current. Those small vectors injecting positive phase currents into the neutral point will be called positive vectors (ONN, PPO, NON, OPP, NNO, POP), while those injecting opposite phase currents will be called negatives vectors (POO, OON, OPO, NOO, OOP, ONO).

 TABLE I
 NEUTRAL POINT CURRENT OF DIFFERENT SPACE VECTORS

| Positive Small vectors | i_{d0} | Negative Small vectors | i_{d0} | Medium Vectors | i_{d0} |
|------------------------|----------|------------------------|----------|----------------|----------|
| ONN | i_1 | POO | $-i_1$ | PON | i_2 |
| PPO | i_3 | OON | $-i_3$ | OPN | i_1 |
| NON | i_2 | OPO | $-i_2$ | NPO | i_3 |
| OPP | i_1 | NOO | $-i_1$ | NOP | i_2 |
| NNO | i_3 | OOP | $-i_3$ | ONP | i_1 |
| POP | i_2 | ONO | $-i_2$ | PNO | i_3 |

Medium vectors also affect neutral point potential. However, as they are not redundant vectors, this influence will not be controlled, being therefore considered as perturbation for the dc-voltage stabilization [13], [14].

The neutral point potential control is based on the use of both two redundant vectors in each sector, in order to inject positive or negative current in neutral point, depending on the value of the two capacitors voltages and the load current (6).

Table II shows the current injected by the six small vectors. By using this table, one proposes the neutral point potential control algorithm of this converter as indicated by (7)-(9).

$$\begin{cases}
 c \frac{dU_{c1}}{dt} = I_{rec} - i_{d1} \\
 c \frac{dU_{c2}}{dt} = I_{rec} + i_{d2} \\
 i_{d0} = -(i_{d1} + i_{d2}) \\
 i_{d1} = F11 \cdot F12 \cdot i_1 + F21 \cdot F22 \cdot i_2 + F31 \cdot F32 \cdot i_3 \\
 i_{d2} = F13 \cdot F14 \cdot i_1 + F23 \cdot F24 \cdot i_2 + F33 \cdot F34 \cdot i_3
 \end{cases} \quad (6)$$

 TABLE II
 NEUTRAL POINT CURRENT OF SMALL SPACE VECTORS

| Vectors | Redundancy (a) | i_{d0} | Redundancy (b) | i_{d0} |
|----------|----------------|----------|----------------|----------|
| Vector 1 | ONN | i_1 | POO | $-i_1$ |
| Vector 2 | PPO | i_3 | OON | $-i_3$ |
| Vector 3 | NON | i_2 | OPO | $-i_2$ |
| Vector 4 | OPP | i_1 | NOO | $-i_1$ |
| Vector 5 | NNO | i_3 | OOP | $-i_3$ |
| Vector 6 | POP | i_2 | ONO | $-i_2$ |

For vector 1 and vector 4

$$\begin{cases}
 \text{if } U_{c1} \geq U_{c2} \ \& \ i_1 \geq 0 \Rightarrow \text{redundancy (b)} \\
 \text{if } U_{c1} \geq U_{c2} \ \& \ i_1 \leq 0 \Rightarrow \text{redundancy (a)} \\
 \text{if } U_{c1} \leq U_{c2} \ \& \ i_1 \geq 0 \Rightarrow \text{redundancy (a)} \\
 \text{if } U_{c1} \leq U_{c2} \ \& \ i_1 \leq 0 \Rightarrow \text{redundancy (b)}
 \end{cases} \quad (7)$$

For vector 2 and vector 5

$$\begin{cases}
 \text{if } U_{c1} \geq U_{c2} \ \& \ i_3 \geq 0 \Rightarrow \text{redundancy (b)} \\
 \text{if } U_{c1} \geq U_{c2} \ \& \ i_3 \leq 0 \Rightarrow \text{redundancy (a)} \\
 \text{if } U_{c1} \leq U_{c2} \ \& \ i_3 \geq 0 \Rightarrow \text{redundancy (a)} \\
 \text{if } U_{c1} \leq U_{c2} \ \& \ i_3 \leq 0 \Rightarrow \text{redundancy (b)}
 \end{cases} \quad (8)$$

For vector 3 and vector 6

$$\begin{cases}
 \text{if } U_{c1} \geq U_{c2} \ \& \ i_2 \geq 0 \Rightarrow \text{redundancy (b)} \\
 \text{if } U_{c1} \geq U_{c2} \ \& \ i_2 \leq 0 \Rightarrow \text{redundancy (a)} \\
 \text{if } U_{c1} \leq U_{c2} \ \& \ i_2 \geq 0 \Rightarrow \text{redundancy (a)} \\
 \text{if } U_{c1} \leq U_{c2} \ \& \ i_2 \leq 0 \Rightarrow \text{redundancy (b)}
 \end{cases} \quad (9)$$

III. SIMULATION RESULTS

Simulation is divided in three times. As presented in Fig. 1, induction motor is fed by cascaded three-level rectifier– three-level inverter.

Torque and speed features of induction motor are presented in Fig. 6. In first time ($t=0S-6S$) the motor turns at its nominal speed of 1500 r/min. Medium output voltage U_{cm} of three-level rectifier is equal to its reference $U_{cref}=300V$ (Fig. 7), but the voltages U_{c1} and U_{c2} are unbalanced $U_{c1}=340V-310V$ and $U_{c2}=260V-290V$. One observes also that torque ripple reduce progressively (Fig. 6).

In second time ($t=6S-9S$), we apply the nominal torque of induction motor $T_e=7 \text{ N.m}$. We note that the medium output voltage U_{cm} of three-level rectifier return progressively to its reference after a short decreasing (Fig. 7). Voltages U_{c1} and U_{c2} are more unbalanced ($U_{c1}=310V-370V$ and $U_{c2}=290V-230V$) as consequence, torque ripple increase.

Fig. 8 presents first phase of PWM three-level rectifier current i_{rec10} and its reference $i_{rec10ref}$. This current increase after application of nominal torque of induction motor at $t=6S$.

In third time, the DC bus balancing algorithm of three-level

inverter is applied at $t = 9\text{S}$. We observe that capacitors voltages U_{c1} and U_{c2} are balanced and equal, as consequence the torque ripple are reduced.

Current i_{rec10} and its reference are almost identical and in phase with the first phase network voltage V_{s1} as presented in Fig. 9. It is shown that i_{rec10} current is almost sinusoidal with THD less than 2 % and unity power factor.

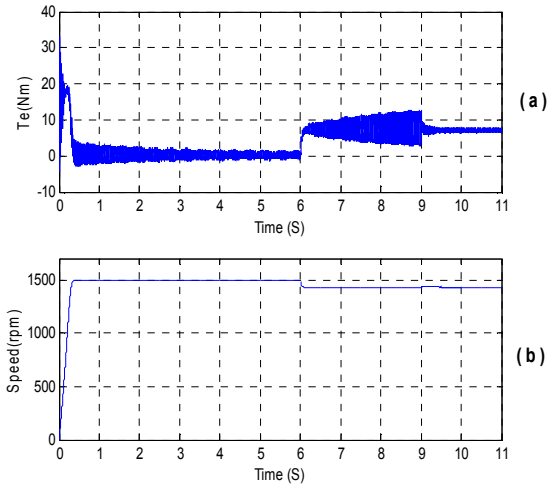

Fig. 6 Induction motor mechanical speed and torque

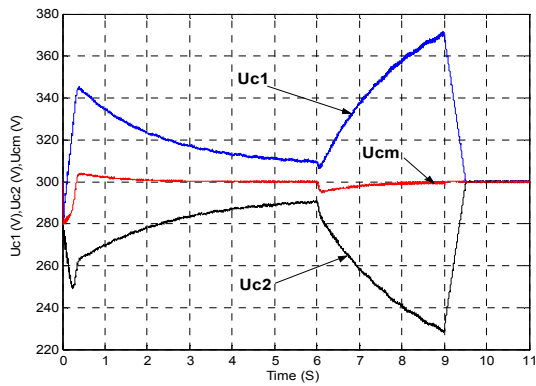

Fig. 7 DC bus capacitors voltages

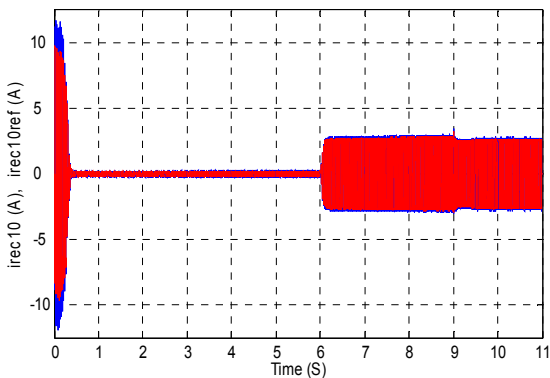

Fig. 8 The network current i_{rec10} and its reference

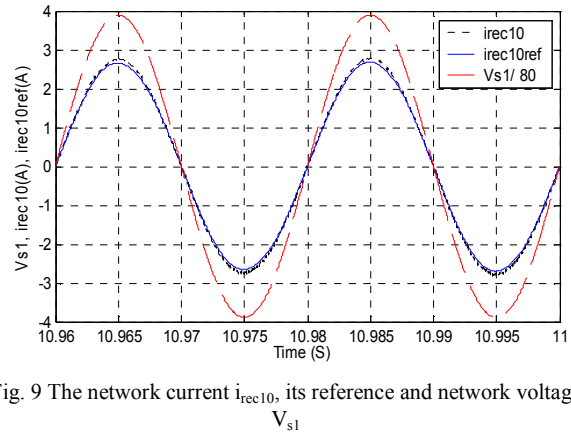

Fig. 9 The network current i_{rec10} , its reference and network voltage V_{s1}

IV. CONCLUSION

In this paper, one studies the problem of unbalance capacitors DC voltages of back-to-back connected three-level converters, which is the main cause of torque ripple in induction motor. The proposed feedback control algorithm to the three-level rectifier associate to the space vector pulse width modulation using the positive and negative small vectors of three-level NPC inverter shows a good following of the medium output voltage of rectifier and the balancing of input voltages of inverter. Consequently, a torque ripple of induction motor is reduced; also, the cascade studied absorbs network currents with minimum harmonics and unity power factor.

REFERENCES

- [1] Joachim Holtz, Lothar Springob "Identification and Compensation of Torque Ripple in High-Precision Permanent Magnet Motor Drives," IEEE Transactions on Industrial Electronics, Vol. 43, No. 2, 1996, pp. 309-320.
- [2] Kyo-Beum Lee, Joong-Ho Song, Choy I, Ji-Yoon Yoo "Torque ripple reduction in DTC of induction motor driven by three-level inverter with low switching frequency," IEEE Transactions on Power Electronics, Vol 17, Issue: 2, 2002 255 – 264.
- [3] Jih-Sheng Lai ,Fang Zheng Peng, "Multilevel converters-a new breed of power converters," IEEE Transactions on Industry Applications, Vol 32 Issue: 3, 1996 509 – 517.
- [4] Rodriguez, J. Jih-Sheng Lai, Fang Zheng Peng, "Multilevel inverters: a survey of topologies, controls, and applications," IEEE Transactions on Industrial Electronics, Vol49 , Issue: 4 2002 724 – 738.
- [5] M. Marchesoni, P. Tenca. "Diode-clamped multilevel converters: A practicable way to balance DC-link voltages," IEEE Transactions on Industrial Electronics, 2002. 49(4): p. 752-765.
- [6] M. Marchesoni, P. Tenca, "Theoretical and Practical Limits in Multilevel MPC Inverters with Passive Front Ends. EPE2001. 2001. Graz.
- [7] J.R. Rodriguez, et al, "PWM regenerative rectifiers: State of the art," IEEE Transactions on Industrial Electronics, 2005. 52(1): p. 5-22.
- [8] F. Bouchafaa, E.M. Berkouk, M.S. Boucherit, "Modelling and control of a power electronic cascade for the multi DC bus supply," The International Journal for Computation and Mathematics in Electrical and Electronic Engineering, vol. 27 n 5, 2008, pp. 1128 – 1143.
- [9] T. Abdelkrim, K. Benamrane, E.M. Berkouk, T. Benslimane, "Feedback control of three-Level PWM rectifier: Application to the stabilization of DC Voltages of five-level NPC active power filter," Archives of Control Sciences, Vol.20, No. 3, pp. 317-339, 2010.
- [10] T. Abdelkrim, E.M. Berkouk, K. Benamrane, T. Benslimane, "Study and Control of Three-Level PWM Rectifier-Five-Level NPC Active Power Filter Cascade using Feedback Control and Redundant Vectors,"

International Review of Electrical Engineering, Vol.5, No. 3, pp. 820-830, 2010.

- [11] D. Lalili, E.M. Berkouk, F. Boudjema, N. Lourci, N, "Simplified space vector PWM algorithm for three-level inverter with neutral point potential control," The Mediterranean Journal of Measurement and Control, Vol. 3, No. 1, pp. 30-39, 2007.
- [12] N. Celanovic, "Space vector modulation and control of multilevel converters," Ph.D.thesis, Virginia Polytechnic Institute and State University, Blacksburg, Virginia, USA, 2000.
- [13] Y. Liu, X. Wu, L. Huang, "Implementation of three-level inverter using a novel Space vector modulation algorithm," Proc. IEEE Conf. on Power System Technology, PowerCon, Vol. 1, pp. 606-610, 2002.
- [14] T. Abdelkrim, K. Benamrane, E.M. Berkouk, T. Benslimane, "Neutral Point Potential Balancing Algorithm for Sliding Mode Controlled Three-Level Active Power Filter," Journal of Electrical Engineering, Vol.11, No. 1, pp 135-141, 2011.