

Thermal Cracking Response of Reinforced Concrete Beam to Gradient Temperature

L. Dahmani, and M.Kouane

Abstract—In this paper are illustrated the principal aspects connected with the numerical evaluation of thermal stress induced by high gradient temperature in the concrete beam.

The reinforced concrete beam has many advantages over steel beam, such as high resistance to high temperature, high resistance to thermal shock, Better resistance to fatigue and buckling, strong resistance against, fire, explosion, etc.

The main drawback of the reinforced concrete beam is its poor resistance to tensile stresses. In order to investigate the thermal induced tensile stresses, a numerical model of a transient thermal analysis is presented for the evaluation of thermo-mechanical response of concrete beam to the high temperature, taking into account the temperature dependence of the thermo physical properties of the concrete like thermal conductivity and specific heat.

Keywords—Cracking, Gradient Temperature, Reinforced Concrete beam, Thermo-mechanical analysis.

I. INTRODUCTION

In this paper are illustrated the principal aspects connected with the numerical evaluation of thermal stress induced by thermal gradient in the reinforced concrete beam.

Their use at high temperatures creates thermal stresses. Temperature distribution data of thermal analysis is required in the coupled field analysis finally to obtain and analyze thermal stresses. It is, therefore, proposed to take up a heat conduction problem using finite element method to obtain temperature distribution data of a reinforced concrete beam at high temperatures.

The basis for thermal analysis in ANSYS [2],[3],[4] is a heat balance equation obtained from the principle of conservation of energy. (For details, consult the *ANSYS, Inc. Theory Reference*.)

$$k \frac{\partial^2 T}{\partial x^2} + k \frac{\partial^2 T}{\partial y^2} + \dot{q} = \rho c \frac{\partial T}{\partial t} \quad (1)$$

Where c is the specific heat coefficient [$J / (kg \cdot ^\circ C)$]: k is the thermal conductivity coefficient [$W / (m \cdot ^\circ C)$]: ρ is the density [kg / m^3]: \dot{q} is the heat generation rate [$J / (m^3 \cdot s)$]

Assuming that no heat generation rate exists in the hardened concrete, the term \dot{q} can be neglected.

The finite element solution performed via ANSYS calculates nodal temperatures, and then uses the nodal temperatures to obtain other thermal quantities. The elastic stresses, induced by mechanical constraints and thermal strains resulting from the previous analysis, have been calculated.

II. FINITE ELEMENT MODEL

A solid reinforced concrete beam model shown in Fig. 1 is discretized with a 3D finite element model as shown in Fig. 2. Its mechanical properties are given in Table I.

A beam is composed of two regions; a concrete element without reinforcement and a concrete element with a smeared reinforcement (Fig. 3).

A thermal version of the model was used to calculate the temperature profile in the concrete beam; a structural version of the model then read the temperature profile to calculate stresses.

A three-dimensional eight noded tetrahedral element having thermal degree-of-freedom (element type solid 70 in ANSYS 8.0) is chosen for heat conduction problem.

The distributions of thermal elastic stress components were then calculated by switching the solid 70 thermal element to solid 65 structural element (Fig. 6) which is used for 3-D modelling of solid structures [2],[3].

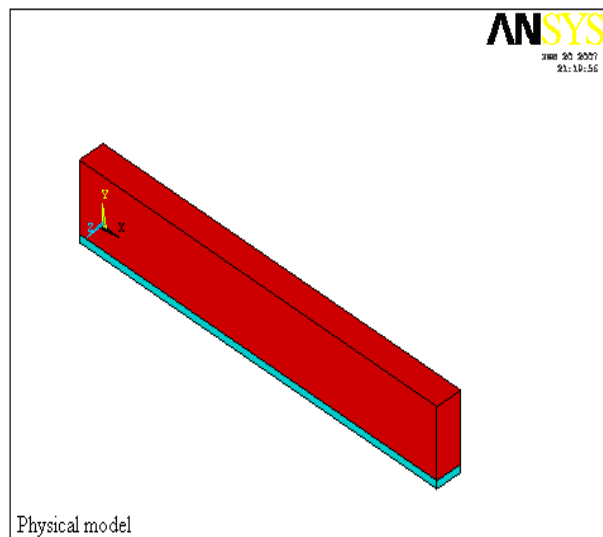

Fig. 1 Physical model

Lahlou Dahmani is with the Civil Engineering Department, University Mouloud Mammeri, Tizi-Ouzou, Algeria (e-mail: lahlou_d@yahoo.fr).

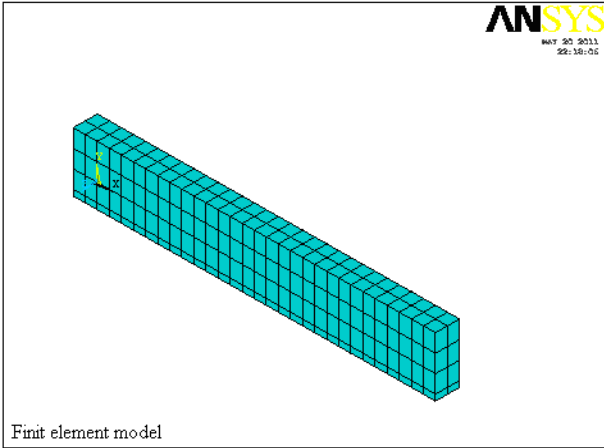

Fig. 2 Finite element model

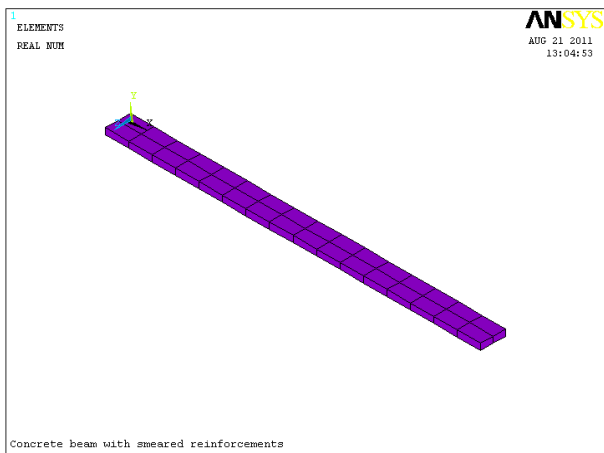

Fig. 3 Smeared reinforcements

Based on a differential equation (1) with tacking into account of the spatial temporal boundaries conditions, the heat balance for the structural nodes at time $(t+\Delta t)$ is given by:

$$[C]\{\dot{T}(t + \Delta t)\} + [K]\{T(t + \Delta t)\} = \{F\} \quad (2)$$

Where $[C]$ is the heat capacity matrix containing the specific heat coefficients c ; $[K]$ is the conductance matrix containing the thermal conductivity terms (k) and heat exchange coefficients (h); $\{\dot{T}\}$ is the nodal temperature rate vector $\partial T / \partial t$; $\{F\}$ is the thermal load vector.

A classical Euler scheme can be implemented. If we assume the following approximation for the first time derivative of the temperature field [9]:

$$\{T(t + \Delta t)\} = \{T(t)\} + (1 - \theta)\Delta t \{\dot{T}(t)\} + \theta\Delta t \{\dot{T}(t + \Delta t)\} \quad (3)$$

being $\theta = [0, 1]$ and ΔT the time step, we can rewrite, after some manipulation, (2) as:

$$\left(\frac{1}{\theta\Delta t}[C] + [K] \right) \{T(t + \Delta t)\} = \{F\} + [C] \left(\frac{1}{\theta\Delta t}\{T(t)\} + \frac{1-\theta}{\theta}\{\dot{T}(t)\} \right) \quad (4)$$

A transient thermal analysis follows basically the same procedures as a steady-state thermal analysis. The main difference is that most applied loads in a transient analysis are functions of time. To specify time-dependent loads, one can divide the load-versus-time curve into load steps.

III. THERMAL AND STRUCTURAL BOUNDARY CONDITIONS

A temperature of 600°C was applied to the base of the concrete beam, and 25°C was applied to the upper face by convection with a film coefficient of $50\text{ W/m}^2/\text{C}$ (Fig. 4 et 5). The concrete initial temperature is set to 20°C .

The temperature is obtained via Galerkin finite element technique as implemented by ANSYS software package [2],[3],[10].

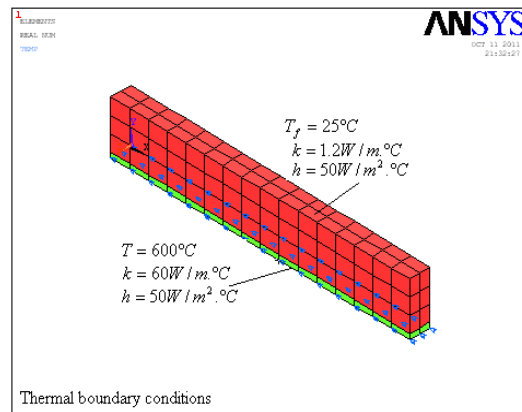

Fig. 4 Thermal boundary conditions

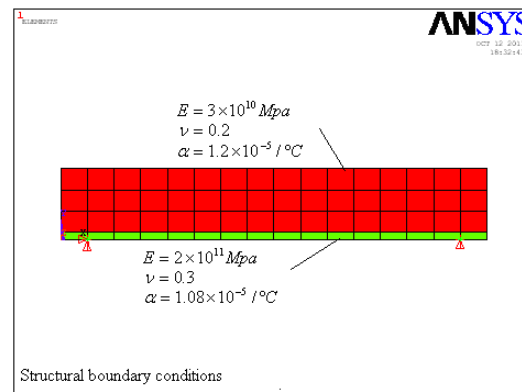

Fig. 5 Structural boundary condition

TABLE I
THERMAL AND STRUCTURAL ELEMENTS

Element	Thermal	Structural
Type	SOLID 70	SOLID 65
Number of nodes	8	8
Number of DOF per node	1	2
Nature	Temperature	Displacement Ux and Uy

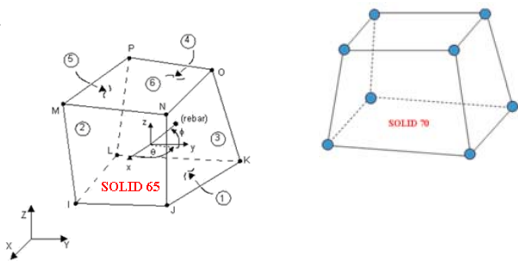

Fig. 6 Thermal and structural element

TABLE II
MATERIAL PROPERTIES OF CONCRETE AND STEEL [6]

Material properties	Concrete	Steel
Compressive strength	$f'_c = 30Mpa$	-----
Tensile strength	$f_t = 2.5Mpa$	-----
Yield strength	-----	$f_y = 240Mpa$
Elastic modulus	$E = 30000Mpa$	$E = 200000Mpa$
Poisson's ratio	$\nu = 0.2$	$\nu = 0.3$
Density	$\rho = 2400kg / m^2$	$\rho = 7875kg / m^2$
Thermal conductivity	$k = 1.2W / m.^{\circ}C$	$k = 60W / m.^{\circ}C$
Specific heat capacity	$c = 1000J / kg.^{\circ}C$	$c = 500J / kg.^{\circ}C$
Thermal expansion coefficient	$\alpha = 1.2 \times 10^{-5} / ^{\circ}C$	$\alpha = 1.08 \times 10^{-5} / ^{\circ}C$

IV. THERMAL ANALYSIS

The boundary conditions are implemented and the problem is solved using Frontal solver in ANSYS. The temperature distribution results are obtained in the general postprocessor. The results so obtained are plotted in Fig. 7 for the temperature profiles and Fig. 8 for the thermal flux vector.

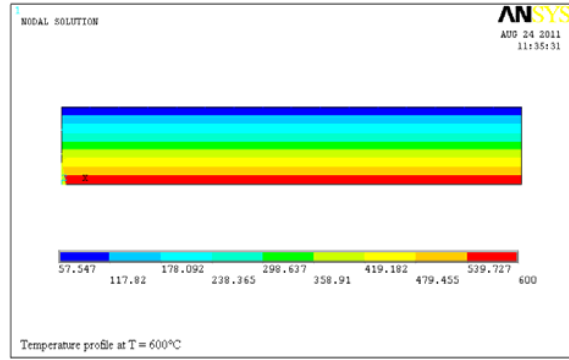

Fig. 7 Temperature profile at (T = 600°C)

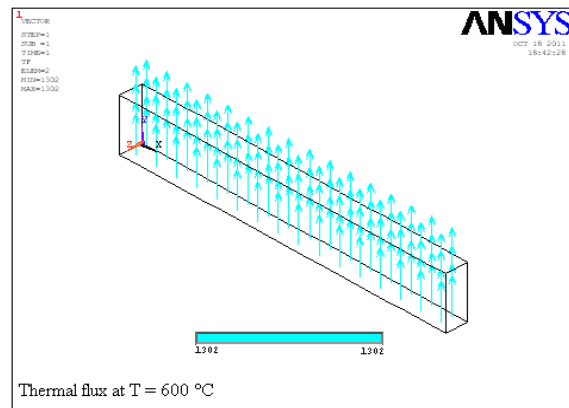

Fig. 8 Thermal flux at (T = 600°C)

V. STRUCTURAL ANALYSIS

The relation between the temperature variation and the associated mechanical strain (thermal strain) can be expressed as follows:

$$\epsilon_{thermal} = \alpha \Delta T \tag{5}$$

Where $\epsilon_{thermal}$ is the thermal deformation, α is the thermal coefficient of expansion ($^{\circ}C^{-1}$), and ΔT is the thermal gradient ($^{\circ}C$). The simulation of the thermal transfer and the associated thermal stresses can be carried out by using the transient thermal stress analysis, which is available in the finite element commercial code ANSYS.

Thermal-stress applications are treated in a so-called *coupled-field analysis*, which takes into account the interaction between thermal expansion/contraction and mechanical stress. Because in the present case strain does not influence on temperature, we are in a *one way* coupling situation best handled by the *indirect method*, where nodal temperatures from a (time transient) thermal analysis are applied at a *specified time* in the subsequent (steady state) stress analysis. The change from thermal to structural analysis is easily achieved in ANSYS as the element switch is automatic. Thermal SOLID70 elements to structural SOLID

65 elements type. The temperatures obtained from the previous analysis are now applied as a load to determine thermal stresses and displacements and other quantities (Figs. 9, 10 and 11).

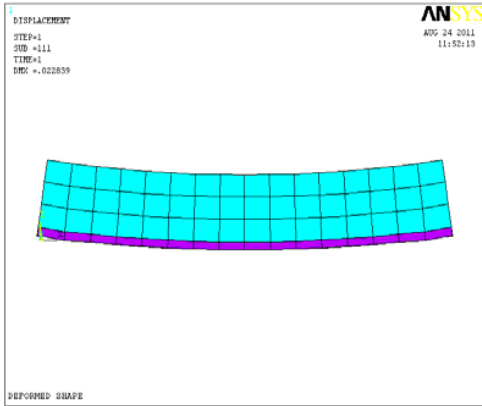

Fig. 9 Deformed shape

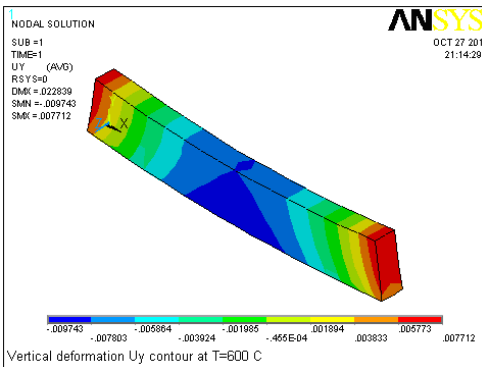

Fig. 10 Vertical deformation contour Uy

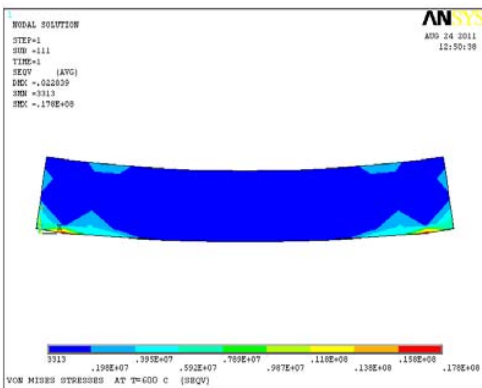

Fig. 11 Von Mises stresses

VI. CRACKING ANALYSIS

The William and Warnke failure criterion [11] under multi-axial stress state is adopted to assess the initiation of failure and identify the corresponding failure modes (including cracking and crushing) at the centroid of a concrete element or

one of its integration points. The criterion is expressed uniformly as:

$$\frac{F}{f'_c} - S \geq 0 \tag{6}$$

where F is a function of the principal stresses, S is the spatial failure surface expressed in terms of the principal stresses and the material properties of concrete, and f'_c is the maximal compressive strength of concrete. Only if (6) is satisfied, will the failure of concrete element or that of its integration points be assumed to occur [5],[8],[9].

The cracking state of the reinforced concrete beam at different temperature is illustrated in Figs. 12, 13 and 14. It can be observed that more and more dense micro cracks uniformly distributed over the beam supports propagate with the increasing temperature.

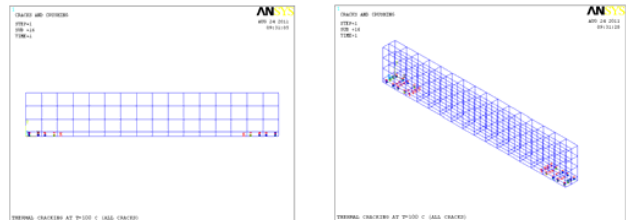

Fig. 12 Thermal cracking at T=100°C

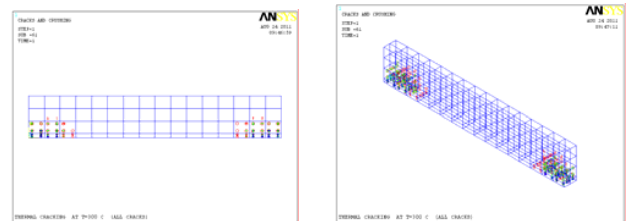

Fig. 13 Thermal cracking at T=300°C

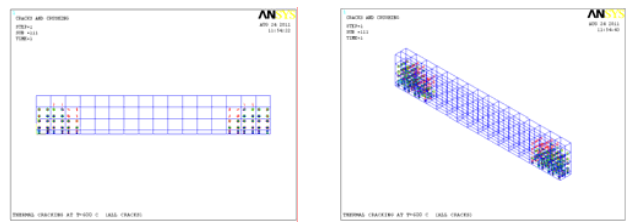

Fig. 14 Thermal cracking at T= 600°C

VII. RESULTS AND DISCUSSION

According to the obtained results, the gradient temperature produced:

- a great thermal gradient and thermal flux between the base and the top of the beam (Figs. 7 and 8).
- a great vertical deformation and Von Mises stress around the support regions (Figs. 9, 10 and 11).

- a cracking accumulation and propagation around the beam supports with the increase of temperature (Figs. 12, 13 and 14). This could worsen the static behaviour and the structural integrity of the concrete beam.

The risk could be prevented with the adoption of suitable measurements:

- The insertion of the reinforcements in the tension zones and the support regions to strengthen the concrete, thus reducing the formation of the cracks,
- Providing prestress to control cracks,
- The use of a high performance concrete to increase resistance and to decrease the permeability [1],[7].
- Using lightweight aggregate concrete can benefit the prevention of thermal cracking. The lightweight aggregate concrete has larger strain at cracking, and thus, can sustain more thermal deformation before cracking [1],[7].

VIII. CONCLUSION

This work deals with the peculiar aspects connected to the numerical modelling of thermal induced stresses in the reinforced concrete beam. The ANSYS finite element code has been employed for performing a sequential, non linear, transient thermal-structural analysis, taking into account the thermal dependant properties of the concrete as thermal conductivity and specific heat.

As shown from the analysis results, the high temperature gradient between the base and the top of the beam induce the appearance of high values of tensile stress which could worsen the static behaviour of the concrete beam by causing the cracking of the concrete and worsen the structural integrity of the beam.

Moreover, these results provide the basis for further studies that will be carried out in order to better investigate the degree of damage and the safety aspects connected with thermal induced stresses in the reinforced concrete beam to high gradient temperature.

The example problem represents the thermal and structural analysis of a concrete beam. In addition to the solution of the temperature and thermal stress response obtained, this example highlights the ease of using a single finite element method with common model discretization to carry out both analyses. Such procedure is useful especially for thermal stress problems that have complex geometries.

REFERENCES

- [1] Alfaiate, J.; Pires, E.B.; Martins, J.A.C., "A Finite Element Analysis of Non-Prescribed Crack propagation in Concrete". *Computers & Structures*, Vol. 63, No. 1, 1997, pp. 17-26.
- [2] "ANSYS Theory Reference: Analysis tools", 001099, 9th ed. SAS IP, Inc.
- [3] ANSYS Thermal Analysis: Tutorial for Rev. 5.0, DN-T031:50, 6., 1992.
- [4] Dahmani, L., "Thermo mechanical response of LNG concrete tank to cryogenic temperatures", *Strength of Materials*, Vol. 43, No. 5, 2011, pp. 526-53.
- [5] Dahmani, L., Khennane, A., Kaci, S., "Crack identification in reinforced concrete beams using ANSYS software", *Strength of Material Journal*, Ed. Springer New York, Vol.42, N°2, Mai 2010, pp. 232-240.
- [6] Dahmani, L., Khennane, A., Kaci, S., « Behavior of the reinforced concrete at cryogenic temperature », *Cryogenics*, Volume 47, Issues 9-10, September-October 2007, Pages 517-525.
- [7] DeBorst, R.; "Some Recent Developments in Computational Modeling of Concrete Fracture". *International Journal of Fracture*, No. 86, No. 1-2, 1997, pp. 5-36.
- [8] Loo, Y.C.; Guan, H., "Cracking and Punching Shear Failure Analysis of RC Flat Plates". *ASCE Journal of Structural Engineering*, Vol. 123, No. 10, 1997, pp. 1321-1330.
- [9] Ngo, D. and Scordelis, A.C., "Finite Element Analysis of Reinforced-Concrete Beams". *Journal of the American Concrete Institute*, Vol. 65, No. 9, 1967, pp.757-766.
- [10] Moaveni, S., "*Finite Element Analysis: Theory and Application with ANSYS*", Pearson Education Inc., 2003, New Jersey.
- [11] William, K.J. and Warnke, E.P., "Constitutive Model for the Triaxial Behavior of Concrete". *Proceedings of the International Association for Bridge and Structural Engineering*, Vol. 19, ISMES, Bergamo, Italy, 1975, pp. 174.