

The Role of Brand Loyalty in Generating Positive Word of Mouth among Malaysian Hypermarket Customers

S. R. Nikhashemi, L. Haj Paim, Ali Khatibi

Abstract—Structural Equation Modeling (SEM) was used to test a hypothesized model explaining Malaysian hypermarket customers' perceptions of brand trust (BT), customer perceived value (CPV) and perceived service quality (PSQ) on building their brand loyalty (CBL) and generating positive word-of-mouth communication (WOM). Self-administered questionnaires were used to collect data from 374 Malaysian hypermarket customers from Mydin, Tesco, Aeon Big and Giant in Kuala Lumpur, a metropolitan city of Malaysia. The data strongly supported the model exhibiting that BT, CPV and PSQ are prerequisite factors in building customer brand loyalty, while PSQ has the strongest effect on prediction of customer brand loyalty compared to other factors. Besides, the present study suggests the effect of the aforementioned factors via customer brand loyalty strongly contributes to generate positive word of mouth communication.

Keywords—Brand trust, perceived value, perceived service quality, brand loyalty, positive word of mouth communication.

I. INTRODUCTION

CUSTOMERS can simply make assumptions about the quality of a brand based on the information obtained via mates, families, or work partners [1]. Word-of-mouth communication (WOM) as one of the earliest form of marketing communication [2] is regarded as an indicator of judgment and selection a new product or service [3]-[7], as well as the most effective method of advertisement [8] and selling unknown products [9]. WOMC is described as a positive or negative oral communication among people recommending products [2]. Odin, Odin [1] defined WOMC as "informal communication directed at other consumers about the ownership, usage or characteristics of particular goods /services/ store" (p.261).

Indeed, marketing research on WOMC, as stated by [10], is scarce due to the product provider's inability to control this phenomenon. Unlike commercial advertisements which sometimes fail to create trust among customers, word-of-mouth communication among trustable friends or relatives is able to create trust and eventually influence customers' purchase decisions more than other sources of information [11], [12]. One simple yet difficult question which needs to be

answered in retailing business is how WOMC can be generated in order to attract and retain customers. To do so, one of the important factors which can facilitates the process of positive WOMC is customer brand loyalty development, which can help the retailers to improve their long-term profitability in a very viable retailing situation. Numerous studies have been conducted on WOMC as an outcome of customer brand loyalty, but still the antecedents of customer brand loyalty in Malaysian's hypermarket industry which can contribute to positive evaluation of customers towards the brand and positive WOMC have been underestimated. To address this issue, by adapting a theoretical framework from Mean-end theory, the present study attempts to examine whether customer perceived service quality, perceived value, brand trust can be considered as antecedents of CBL in Malaysian hypermarket context and also investigates whether customer brand loyalty can effect positive word of mouth communication. The study will further suggest appropriate management strategies that can assist retailers to understand the important role of customer brand loyalty in generation positive word of mouth communication. Besides, the findings of current study provide reference material for future researchers of hypermarkets in Malaysia which is very limited.

II. MEANS- END-THEORY AND BRAND LOYALTY

As a theory of consumer behavior, means end theory, has been applied to explain the concepts of customer brand loyalty. This theory emphasizes how personal values influence individual behavior. Reference [2] defined personal value as a centrally held, enduring belief which guides the actions and judgments across specific situations and beyond the immediate goals to more ultimate end-states of existence. Reference [13] initiated means end theory as one of the theories that the attachment of a brand by human personality can be explained. Values are found to be customer's criteria in purchasing and decision making [3]-[5]. Individual personal values such as reasonable price, and satisfactory level of service, in particular hypermarket, eventually leads customer to perceive satisfaction and positive perceive value as well as happiness [2]. Perceived value is defined as an overall assessment of customer with regards to product utility depending on the perceptions of what is received and given [4], [2] suggest that perceived value can positively affect customer loyalty. It is observed that the cognitive part of the brand which is naturally tangible can be assessed by the customers before emotional brand attachment [6], [7]. Consequently, cognitive part of the

Nikhashemi S.R is with Sunway University, Business School, Department of Marketing, Sunway (e-mail: farhadn@sunway.edu.my).

Laily Haj Paim is with Universiti Putra Malaysia, Department of Management and Consumer Studies (e-mail: laily@upm.edu.my)

Ali Khatibi is with the Graduate School of Management, Management and Science University of Malaysia (MSU) (e-mail: alik@msu.edu.my)

brand is tends to be evaluated by customer which is usually happening before they can engage with the brand emotionally [6]. Accordingly hypermarket's brand encompasses the level of means- end hierarchy as possessing: a) the level of physical and sensory attributes where the brand sign, trust, service quality and product quality can be acknowledged, b) the stages of direct functional implication of these traits focusing on their advantages and disadvantages, c) the level of symbolic values or meaning, where feeling of attraction, expressive values, terminal values and social values are connected [7].

Brand Loyalty

There are three standpoints to view the concept of brand loyalty namely attitudinal, behavioral and composite loyalty. Embracing specified preferences, promise, or purchase targets of the consumer is often regarded as attitudinal loyalty, thus researchers holding this standpoint emphasize on the psychological component of brand loyalty [8]. On the contrary, behavioral researchers assume that recurrence of transactions exemplify the brand loyalty of a consumer [9]. Additionally, there is a more realistic picture provided by behavioral approach on how well brand is performing compared to its competitors. [9] stated that the disability to differentiate between true and spurious loyalty is the reason for disapproval of behavioral measures as the sole indicator of loyalty [1]. Although attitudinal loyalty consideration assists the examiner to differentiate brand loyalty from frequent purchase, it does not focus on actual purchase, instead focuses on consumer testimonies and that is why it may not be a precise exemplification of reality [1]. In other words, genuine purchase behavior may not be guaranteed by an optimistic manner toward a brand. On the other hand, loyalty is regarded as a subjective behavioral purchase exercise due to the emergence of a psychological process [10]. Reference [9] strongly recommended the composite approach where the assessment of a consumer's loyalty to a specific branding necessitates synchronized reflection of purchase behavior and attitudes. Past studies on brand loyalty have acknowledged the composite view (e.g., [11], [12]).

The contribution of perceived value, brand trust and consumer perceived service quality in building brand loyalty have been well-documented by scholars [9]. Evaluative judgment is viewed in accordance to the customer's real service experience, perceived value, service quality and hypermarket attributes [13] and evaluating service variables [14], [15] while brand trust is recognized as a variable of relation [16], arguing that in this process consumer experience with the brand as the main factor leads to the attribution of a trust image to the brand [9], [17]. Therefore, the service transaction greatly influences the consumer assessment of these elements, while the service experience and customer brand loyalty will influence positive WOMC in a hypermarket context. On the other hand, previous studies propose that the vibrant relationships between the brand and a consumer is contributed by several factors of psychology such as brand trust [18].

A. The Effect of Customer Perceived Service Quality on Brand Loyalty

Perception of customer about service quality will represent the customer's experience and assessment about a product's entire dominance [4]; therefore, the quality of service perceived by customer would determine the extent of a customer's loyalty towards a brand or product [19]. The relationship can be enlightened by the Model of the Behavioral Consequences of Service Quality [5] averring that high evaluation of service quality would more likely affect customers' satisfactory behavioral goals, such as loyalty. This effect would arise as the result of enriched service quality which assist customers promote a satisfactory attitude toward a service supplier; accordingly it can potentially develop loyalty among brand customers[9], [20]. On the basis of what we have discussed so far, the proposed hypothesis is as follows:

H1. There is a positive association between service quality and customer brand loyalty.

B. The Effect of Customer Perceived Value on Customer Brand Loyalty

The effectiveness of an image of brand, a product, and a store depends on customer's general evaluation of what they have received and what they have given embracing the concept of perceived value [4]. An excellent customer goal, value can potentially control customer actions targeting behavioral loyalty [16]. Customer perceived value is found to affect purchase intention, commitment and customer brand loyalty [16], [21]. For this reason, we also propose that:

H2. There is a positive association between customer perceived value and customer brand loyalty.

C. The Effect of Brand Trust on Customer Brand Loyalty

Reference [22] defined brand trust as "The confident expectations about the brand's reliability and intentions in situations entailing risk to the consumer" (p.586). By creating network relationships, brand commitment and loyalty are explained through brand trust [23]. Governed by loyalty, a vital association and worthy value shaped by trust is sustained and supported [24]. Trust is an important antecedent of customer brand loyalty [19], [25]. [23]. In other words, loyalty can be developed based on the significant relationship created by trust [24]. With regard to this, following hypothesis has been developed:

H3. There is a positive association between Brand Trust and customer brand loyalty.

D. The Effect of Customer Brand Loyalty on Positive Word of Mouth Communication

Word of mouth underlies idea of product information, the positive image of store and brand can flow from each customer to others [26]. WOMC is known as a distinguished approach of integrated marketing communication and has become particularly prevalent in marketing research and consumer science studies, eventually plays a major key towards constructing the attitudes and behaviors of customer. [9]. Recently, studies in consumer behavior and relationship

marketing have proposed that WOMC might be a reflection of direct intention with customer association [26]. With regards to comprehensive reason, the findings of previous customer studies suggest positive effect of customer brand loyalty on giving rise to positive WOMC [27], [28]. Scholars report that customers who share the same feeling with the company consider promoting the brand or products to others (in this case hypermarket) regularly and pay the brand compliments [29], [30]. Faithful customers are likely to support the company by highlighting the major traits of their products or services [31]. The positive effect of emotional commitment on WOMC is identified by the previous researchers [31], [32]. Therefore, the proposed hypothesis is:

H4. Customer brand loyalty positively influences positive word of mouth communication.

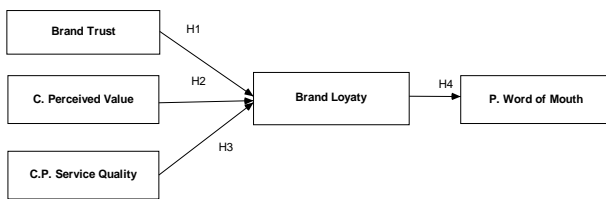

Fig. 1 Research Framework

III. RESEARCH METHODOLOGY

A. Pre-Test

Pre-test has been conducted to identify the suitability of instrument design, such as format, content, and also understanding of the terminology of the items. The data for pretest analysis was collected from convenience samples of 60 graduate and postgraduate students and some of the lecturers of University Putra Malaysia who have a shopping experience at least once a week from hypermarkets. The participants included approximately equal numbers of men and women. The reliability of the instrument has been analyzed and the obtained overall result of Cronbach's alpha for 30 items was 0.958 which demonstrate a strong consistency among the items.

B. Data Collection and Sampling

The quantitative method was applied to test the research hypotheses of customers' perceptions of hypermarket brands through constructing a survey questionnaire. The survey questionnaires were disseminated to a handy sample of 400 Malaysian hypermarket customers in Malaysia. Using the convenience sampling technique, by obtaining units or people who are conveniently available, a total of 300 customers completed the survey with a response rate of 75 percent. Non-probability sampling can also be used by selecting the respondents on the basis of personal judgment or convenience [33], [34]. In most studies, researchers conducted non-probability sampling due to improper sampling's frame and this method widely accepted in consumer science as well as marketing research [35].

C. Measurement

Five broadly accepted and applied scales were used to measure the constructs of interest in this study. For all questionnaires, a 7-point Likert-type agreement measure on a 1 (strongly disagree) to 7 (strongly agree) scale was considered. First, perceived service quality was measured through a short six-item scale adapted from [14], [36]. Second, perceived value was measured using an eight-item scale adapted from [9], [37], [38]. The third scale was for brand trust and utilized 6 items adapted from previous researchers [38], [39], [9]. The fourth scale adapted items from [4], [9] measured customer brand loyalty and contained 7 items. Lastly, positive word-of-mouth communication was measured with 6 items from [9], [40], [14]. Table I shows each scale's reliability and number of items.

IV. RESULTS AND DISCUSSION

A. Sample Profile

The participants were approximately equal numbers of men and women aged between 18 to 64 years, with an average age of 49. In terms of gender composition, 57.2 percent of respondents (n = 214) were male and 42.8 percent (n = 160) were female. In relation to the ethnic background, 40.6 (152) were Malay followed by 28.9 (108) international; 14.2 (53) Malaysian Chinese; and 16.7(61) were Indian Malaysians.

B. Descriptive Analysis of Reliability Test

The factors were coded and reliability test was conducted on the 35 items. The reliability test was analyzed and summarized accordingly. The measures of reliability showed that Cronbach's Alpha range in value from 0 to 1, with values of 0.60 to 0.70 which can be considered as a reliable level [34]. Overall, the Cronbach's Alpha is at 0.955, which is above minimum limit, demonstrating that the questionnaires strongly is reliable [34], [41]. The results of factor no. 1 (Customer perceived Service Quality), showed that for all the 8 items, Cronbach's Alpha for overall scale is 0.733. An examination of the items conspiring customer perceived service quality indicates that the item SQ1 (-0.080) and SQ4 (0.125) have the lowest correlated item-total correlation, therefore, both SQ1 and SQ4 were deleted from the scale "Alpha if item deleted" columns as the total reliability increases significantly to 0.831 ($0.7 \leq \alpha \leq 0.9$) which indicates a good internal consistency among the items. The Cronbach's Alpha for overall scale for factor no. 2 (customer perceived value among Malaysian hypermarket's customer) is 0.717. An examination of all the 9 items indicates that the item PV3, has the lowest (-0.111) correlated item- total correlations. However, the total reliability would increase marginally to 0.759 if this item is removed from the scale the "Alpha if item deleted" columns. It is preventable to delete this item, but the item will be reworded to improve the value. However the Cronbach's Alpha for overall scale for factor no.3 (Brand trust) is 0.784 which has been measured by 6 items ($0.7 \leq \alpha \leq 0.9$) which represents the good internal consistency among the items. An examination of all the 6 items indicates

that item BT2, has the lowest (0.281) correlated item- total correlations. If this item is removed from the scale the "Alpha if item deleted" column shows that the overall reliability would increase slightly to 0.798. In this case, removing of this item is believed to be unnecessary as the overall Cronbach's Alpha), 0.784 still considers as a good internal consistency. The Cronbach's Alpha for overall scale for factor no. 4 (Customer brand loyalty) is 0.813 which has been measured by 9 items ($0.7 \leq \alpha \leq 0.9$) which represents the good internal consistency among the items. An examination of all the 9 items indicates that the lowest correlated item- total correlations belong to CBL1 (0.072) and CBL2 (0.151). The overall reliability would increase marginally to 0.864 in case these CBL1 and CBL2 remove from the scale the "Alpha if item deleted" column. The overall Cronbach's Alpha, 0.813 is still close to 1; hence, deleting the respective item is pointless. For factor no. 5 (word of mouth communication), provides that for all the 6 items, Cronbach's alpha for overall scale is 0.749 ($0.7 \leq \alpha \leq 0.9$) which shows the good internal consistency among the items. Table I represents a reliability test of all variables.

TABLE I
RELIABILITY TEST

Variable	Cronbach's Alpha	Number of Items
BT	0.748	6
PSQ	0.831	6
PV	0.759	8
CBL	0.864	7
WOMC	0.749	6

C. Construct Validity

In order to discover the underlying factors associated with 33 items, Exploratory Factor analysis was conducted by using Principal Component Analysis. The construct validity adopted Bartlett's Test of Sphericity. Meanwhile, to measure the sampling adequacy and analyze the level of connection among variables, Kaiser-Mayer-Olkin will be employed. Additionally, the suitability of factor analyses to the data also was computed by the Kaiser-Meyer-Olkin (KMO) test and Bartlett's test. In this study the KMO value was 0.880 and Bartlett's test was significant at the .000 level. However according to [41], [42], the items with low factor loading (<0.45) or high cross loading (>0.40) are suggested to be deleted.

D. Convergent Validity: Confirmatory Factor Analysis

To evaluate the performance of measurement model which has used in this study, a confirmatory factor analysis (CFA) is used in the direction of evaluating the performance of measurement model in this study together through five constructs representing by AMOS 19.0 via maximum likelihood estimation. The SEM program AMOS was used throughout the study to conduct the analyses. In order to evaluate five model, this research assessing both measurement and structural model. According to [43, 44] the convergent validity will be achieved, while Average Variance Extracted (AVE) is greater than the cut-off point of 0.5, hence in this

study average variance extracted for all constructs were examined (brand trust 0.57, customer perceived value, 0.52, customer perceived service quality 0.69 and finally positive word of mouth (WOM), 0.51) and they have exceeded from recommended cut-off-point level. Nevertheless this study used different types of goodness of fit indicators because one single statistical test is questionable [45]. Therefore, the evaluation of models for this study is based on multiple goodness-of-fit indicators. Table II summarizes the results of these tests.

TABLE II
SUMMARY OF CONFIRMATORY FACTOR ANALYSIS

Factor	X ²	DF	P	GFI	AGFI	CFI	RMSEA
BT	3.127	4	0.003	0.961	0.949	0.987	0.071
PSQ	3.116	2	0.000	0.981	0.972	0.912	0.061
PV	4.288	3	0.001	0.946	0.959	0.982	0.060
CBL	2.376	2	0.001	0.997	0.951	0.972	0.058
WOM	3.210	4	0.000	0.983	0.921	0.988	0.059

E. Results of Structural Model

SEM is used to find the relationship among hypothesized constructs (H1 to H4). Goodness-of-fit demonstrates for this model were $\chi^2 = 3.165$, GFI = .945, CFI = .918, TLI = .928, and RMSEA = .053. Fig. 2 and Table III represented the results of the hypothesized structural model of the current study. However the model revealed that customer brand trust, customer perceived value and service quality have significant influence on customer brand loyalty and overall customer hypermarket brand loyalty has strong impact towards creating positive word of mouth. Especially, customer brand trust is more significant on customer brand loyalty with compare to service quality, since Root Mean Square of Error Approximation is 0.051 and the normed chi-square gives very good value of 1.282. As suggested by (Byrne, 2009), CFI, GFI, AGFI and TLI are larger than or equivalent to 0.90 respectively. Comparing to the result of customer perceived value ($\beta=0.62$), customer perceived service quality is believed to be more significance in Malaysian hypermarkets. Alternatively, overall customer brand loyalty has better association with positive word of mouth generation ($\beta=0.73$). Table III and Fig. 2 represents the result of structural models.

V. CONCLUSION AND LIMITATION OF THE STUDY

This study aims to build up a model which explains positive word of mouth communication throughout brand loyalty among Malaysian hypermarket customers. In spite of numerous investigation by researchers [46], [47] regarding brand loyalty, such investigation has not been carried out among Malaysian hypermarket's customers, hence to fill up this gap this study focused to identify the antecedent of brand loyalty among Malaysian hypermarket customer in order to facilitate the process of positive word mouth communication. Consequently, this study by conducting an Exploratory Factor Analysis found that customer brand trust, perceived value and perceived service quality are the major players of brand loyalty antecedent. The result of this study contributes to the literature of consumer behavior and marketing by

hypothesizing the direct influence of brand trust, customer perceived value and service quality as a sign of customer

brand loyalty, as well as a tortuous consequence in the generating positive word of mouth communication.

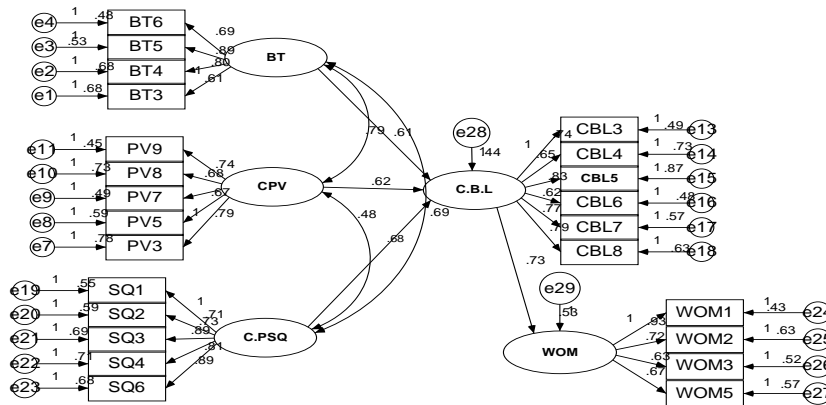

Fig. 2 Hypothesized Structural Model Result

TABLE III
STRUCTURE MODEL RESULT

Dependent Variables	Independent Variables	Hypothesis	Beta Weight	Result
CBL	BT	H1	.61**	Sig
CBL	PV	H2	.62**	Sig
CBL	PSQ	H3	.68**	Sig
WOMC	CBL	H4	.73**	Sig

Goodness-of-fit-Statistics $\chi^2 = 316.65$ ($p < .05$), $\chi^2/df = 1.77$, GFI = .945, CFI = .918, TLI = .928, and RMSEA = .053.

* Significant $P < .05$; ** Significant $P < .01$; *** Significant $P < .001$.

The result of the study revealed that all brand loyalty antecedents (Brand trust, customer perceived value and customer perceived service quality) have a significant outcome on customer brand loyalty, especially customer perceived service quality and overall customer brand loyalty, had a strong result in generating positive word of mouth communication. However, there are a number of limitations in this study, which in future research should not be overlooked. First and foremost, non-probability sampling was used in this study, which generalizability of the result cannot be made. The second study was a scare in the generation of positive word of mouth communication as an outcome of customer brand loyalty in Malaysian hypermarket context. There are some areas which in future can give more attention. First, as the perception level of male and female vary as a result the moderating role of gender will be worth to take into consideration. Second in this study probability sampling hasn't used consequently it will be very useful to test the model by incorporating bigger sample size via a probability sampling method in order to generalized the finding.

REFERENCES

[1] Odin, Y., N. Odin, and P. Valette-Florence, *Conceptual and operational aspects of brand loyalty: an empirical investigation*. Journal of Business Research, 2001. 53(2): p. 75-84.
 [2] Gutman, J., *A means-end chain model based on consumer categorization processes*. The Journal of Marketing, 1982: p. 60-72.

[3] Negash, S., T. Ryan, and M. Igbaria, *Quality and effectiveness in Web-based customer support systems*. Information & Management, 2003. 40(8): p. 757-768.
 [4] Zeithaml, *Consumer perceptions of price, quality, and value: a means-end model and synthesis of evidence*. The Journal of Marketing, 1988: p. 2-22.
 [5] Zeithaml, *The behavioral consequences of service quality*. The Journal of Marketing, 1996: p. 31-46.
 [6] Schultz, M. and L. De Chernatony, *The challenges of corporate branding*. Corporate Reputation Review, 2002. 5(2/3): p. 105-113.
 [7] Osman, I., *The impact of corporate image on customer loyalty of Islamic Banks in Malaysia: Integrating Resource Based and Institutional theory*, 2011, International Islamic University of Malaysia (IIUM), p. 1-413.
 [8] Bennett, R. and S. Rundle-Thiele, *A comparison of attitudinal loyalty measurement approaches*. The Journal of Brand Management, 2002. 9(3): p. 193-209.
 [9] Fung, K.K., et al., *The influence of customer brand identification on hotel brand evaluation and loyalty development*. International journal of hospitality management, 2013. 34: p. 31-41.
 [10] Jacoby, J., *A model of multi-brand loyalty*. Journal of advertising research, 1971. 11(3): p. 25-31.
 [11] Harris, L.C. and M.M. Goode, *The four levels of loyalty and the pivotal role of trust: a study of online service dynamics*. Journal of Retailing, 2004. 80(2): p. 139-158.
 [12] Li, X.R. and J.F. Petrick, *Examining the antecedents of brand loyalty from an investment model perspective*. Journal of Travel Research, 2008. 47(1): p. 25-34.
 [13] Butcher, K., B. Sparks, and F. O'Callaghan, *Evaluative and relational influences on service loyalty*. International Journal of Service Industry Management, 2001. 12(4): p. 310-327.
 [14] Urška Tuškej, U.G.a.K.P., *The role of consumer-brand identification in building brand relationships*. Journal of Business Research, 2013.
 [15] Nikhashemi, et al. *The Mediating Role of Brand Commitment on Generating Word of Mouth Communication: An Investigation in Hypermarket industry in Malaysia*. in ACFEA. 2014. Taiee: Asian Consumer and Family Economics Association
 [16] Sirdeshmukh, D., J. Singh, and B. Sabol, *Consumer trust, value, and loyalty in relational exchanges*. The Journal of Marketing, 2002: p. 15-37.
 [17] Lai, F., M. Griffin, and B.J. Babin, *How quality, value, image, and satisfaction create loyalty at a Chinese telecom*. Journal of Business Research, 2009. 62(10): p. 980-986.
 [18] Hongwei, Y. Li, and L. Harris, *Social identity perspective on brand loyalty*. Journal of Business Research, 2012. 65(5): p. 648-657.
 [19] Aydin, S. and G. Özer, *The analysis of antecedents of customer loyalty in the Turkish mobile telecommunication market*. European Journal of Marketing, 2005. 39(7/8): p. 910-925.
 [20] Delgado and J.L. Munuera, Maria Jesus, *Development and validation of a brand trust scale*. International Journal of Market Research, 2003. 45(1): p. 35-54.

- [21] Cheng, H.-H. and S.-W. Huang, *Exploring antecedents and consequence of online group-buying intention: An extended perspective on theory of planned behavior*. International Journal of Information Management, 2013. 33(1): p. 185-198.
- [22] Delgado and Munuera, *Brand trust in the context of consumer loyalty*. European Journal of Marketing, 2001. 35(11/12): p. 1238-1258.
- [23] Morgan, R.M. and S.D. Hunt, *The commitment-trust theory of relationship marketing*. The Journal of Marketing, 1994: p. 20-38.
- [24] Stokburger Ratneshwar, S., *Drivers of consumer-brand identification*. International journal of research in marketing, 2012.
- [25] Flavián, C., M. Guinaliu, and R. Gurrea, *The influence of familiarity and usability on loyalty to online journalistic services: The role of user experience*. Journal of Retailing and Consumer Services, 2006. 13(5): p. 363-375.
- [26] Brown, et al., *Spreading the word: Investigating antecedents of consumers' positive word-of-mouth intentions and behaviors in a retailing context*. Journal of the Academy of Marketing Science, 2005. 33(2): p. 123-138.
- [27] Rio, B., R. Vazquez, and V. Iglesias, *The effects of brand associations on consumer response*. Journal of Consumer Marketing, 2001. 18(5): p. 410-425.
- [28] Kuenzel, S. and S. V. Halliday, *Investigating antecedents and consequences of brand identification*. Journal of Product & Brand Management, 2008. 17(5): p. 293-304.
- [29] Bhattacharya, C.B. and S. Sen, *Consumer-company identification: a framework for understanding consumers' relationships with companies*. Journal of Marketing, 2003. 67(2): p. 76-88.
- [30] Ahearn, M., C.B. Bhattacharya, and T. Gruen, *Antecedents and consequences of customer-company identification: expanding the role of relationship marketing*. Journal of Applied Psychology, 2005. 90(3): p. 574.
- [31] Casalo, L.V., C. Flavián, and M. Guinaliu, *The role of satisfaction and website usability in developing customer loyalty and positive word-of-mouth in the e-banking services*. International Journal of Bank Marketing, 2008. 26(6): p. 399-417.
- [32] Dick, A.S. and K. Basu, *Customer loyalty: toward an integrated conceptual framework*. Journal of the Academy of Marketing Science, 1994. 22(2): p. 99-113.
- [33] Sekaran, *Research Methods for Business in A Skill- Building Approach* 2010, Wiley. p. 1-467.
- [34] Zikmund, W.G., J.C. Carr, and M. Griffin, *Business research methods* 2012: CengageBrain. com.
- [35] Malhotra, N.K., A. Patil, and S. Kim, *Bias Breakdown Review the alternative methods and prognosis of common method variance in marketing research*. Marketing Research, 2007. 19(1): p. 24.
- [36] Cole, H.S. and K.E. Clow, *A Model Development of Retail Patronage Loyalty*. Journal of Business Studies Quarterly, 2011. 2(2).
- [37] Sparks, B., G. Bradley, and G. Jennings, *Consumer value and self-image congruency at different stages of timeshare ownership*. Tourism Management, 2011. 32(5): p. 1176-1185.
- [38] Chaudhuri, A. and M. Ligas, *Consequences of Value in Retail Markets*. Journal of Retailing, 2009. 85(3): p. 406-419.
- [39] Chaudhuri, A. and M.B. Holbrook, *The chain of effects from brand trust and brand affect to brand performance: the role of brand loyalty*. The Journal of Marketing, 2001: p. 81-93.
- [40] Kim, H.-W., H.C. Chan, and S. Gupta, *Value-based Adoption of Mobile Internet: An empirical investigation*. Decision Support Systems, 2007. 43(1): p. 111-126.
- [41] Hair, R.P. Bush, and D.J. Ortinau, *Marketing research* 2006: McGraw-Hill/Irwin.
- [42] Hair, *Multivariate data analysis*, in *Marketing Research* 2009, McGraw-Hill/Irwin.
- [43] Awang, Z., *A Handbook on SEM, "Structure Equation Modeling" 4th edition*. SEM Using AMOS Graphic. Vol. 4. 2012, University Technology MARA Kelantan: Malaysia Press. 140.
- [44] Bagozzi, R.P. and Y. Yi, *On the evaluation of structural equation models*. Journal of the Academy of Marketing Science, 1988. 16(1): p. 74-94.
- [45] Byrne, B.M., *Structural equation modeling with AMOS: Basic concepts, applications, and programming* 2009: CRC Press.
- [46] Nikhashemi, et al., *Driving Forces of Hypermarket's Customer Loyalty: An Empirical Study in Malaysia*. Australian Journal of Basic & Applied Sciences, 2014. 8(3).
- [47] Abu, N.K. and R.M. Roslin, *Identifying service quality dimensions by understanding consumer preferences in the Malaysian grocery retail sector*. Unitar E-journal, 2008. 4(2): p. 57.