

The Evaluation of Load-Bearing Capacity of the Planar CHS Joint Using Finite Modeling

Anežka Jurčíková, Miroslav Rosmanit

Abstract—The subject of this paper is to verify the behavior of the truss-type CHS joint which is beyond the scope of use of the EN 1993-1-8. This is performed by using the numerical modeling in program ANSYS and the analytical methods recommended in the CIDECT publication. The recommendations for numerical modeling of such types of joints as well as for evaluation of load-bearing capacity of the joint are given in this paper. The results from both analytical and numerical models are compared.

Keywords—ANSYS, CHS joints, FEM, Lattice structure.

I. INTRODUCTION

NOWADAYS, for the construction of halls and for spanning large distances, lattice girders or truss frames made of hollow sections are often used conveniently. Main advantages of such structures are their good static effect (biaxially symmetrical cross-section, shortening of the effective lengths, achievement of the required load-bearing capacity while preserving lightweight structure), and also their aesthetic appearance [1].

The most problematic part when designing the steel lattice structure is usually solution of the joints. Design methods given by Eurocode [2] are complicated, difficult to check and offer only limited scope of use (geometric conditions, restriction on material characteristics, only certain types of joints with given types of loads). That is why need arises to verify the behavior of joints which do not comply with the limitations given by the Eurocode.

The subject of this work is a solution of the truss frame structure joint. Due to its geometry, this selected joint cannot be classified as any of the basic type of joints, which load-bearing capacities can be calculated using formulas recommended in the EN 1993-1-8. Consequently, for that joint standardized formulas for calculations of joints' load-bearing capacity cannot be applied.

To describe the behavior of this joint, numerical modeling (using the FEM program ANSYS) and the recommended methods given in the publication Design guide for circular hollow section (CHS) joints under predominantly static loading, CIDECT publishing (Comité International pour le Développement et l'Étude de la Construction Tubulaire) [3]

were used. Mentioned publication offers more possibilities for assessment of CHS joints than the aforementioned Eurocode.

II. DESCRIPTION OF THE SOLVED STRUCTURE

In this paper it is dealt with the solution of the steel truss frame consisting of circular hollow section (CHS) profiles, or more accurately with the solution of the joint in a frame corner (Fig. 2). The frame is axially symmetrical, and a total of six cross-sections have been designed for this structure (I – VI in Fig. 1). For the cross-section No III different thicknesses were considered, $t_0 = 7.1\text{ mm}$ and $t_0 = 8.0\text{ mm}$, for the purposes of comparison. These values were selected on the basis of the subsequent assessment in Section III as a result of the significantly different load-bearing capacities of the joint.

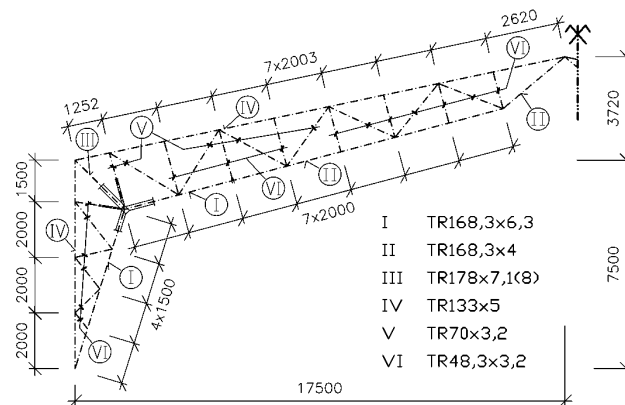

Fig. 1 Geometry of analyzed construction with types of profiles indicated

The joint under consideration has a significant influence in the structure – it is subjected to the greatest loading, and the area of the frame corner is a critical point in general terms. In addition, this joint is interesting for its geometry – considering the joint's asymmetry it cannot be classified as any of the basic type of joints for which the Eurocode EN 1993-1-8 describes the formulas for calculating the load-bearing capacity. According that there is a problem with the assessment of such a joint, which is the aim of this work.

A. Jurčíková is with the Department of Structural Mechanics, Faculty of Civil Engineering, VŠB-Technical University of Ostrava, Ludvíka Podéště 1875/17, 708 33 Ostrava - Poruba, Czech Republic (phone: +420-59-732-1391; e-mail: anezka.jurcikova@vsb.cz).

M. Rosmanit is with the Department of Building Structures, Faculty of Civil Engineering, VŠB-Technical University of Ostrava, Ludvíka Podéště 1875/17, 708 33 Ostrava - Poruba, Czech Republic (e-mail: miroslav.rosmanit@vsb.cz).

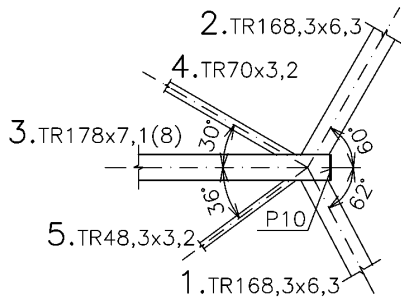

Fig. 2 Detail of analyzed joint, including numbering of individual members

III. ASSESSMENT OF THE JOINT ACCORDING TO CIDECT RECOMMENDATION

Contrary to the Eurocode the publication [3] utilizes classification of hollow section truss-type joints as T (which includes Y), X, or K (which includes N) based on the method of force transfer in the joint, not on the physical appearance of the joint.

Definition of an X joint: „When the normal force component is transmitted through the chord member and is equilibrated by a brace member (or members) on the opposite side, the joint is classified as an X joint.” [3]

According to the mentioned definition, the examined joint has been split into three simple X joints (Fig. 3) whereas maintain the equilibrium of forces in partial joints. The joint design strength was expressed in terms of the efficiency of the connected braces, i.e. the ratio of the axial load of the connected brace – N_{Ed} – and the joint design strength for the appropriate brace N_{Rd} . The resultant efficiency of the brace was then given by the summarization of efficiencies for the individual basic joints (X_A , X_B , X_C).

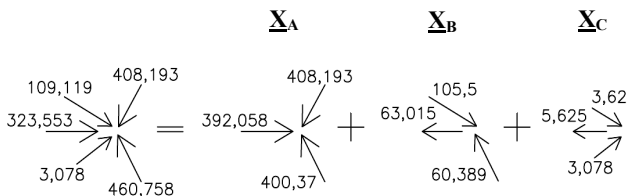

Fig. 3 Splitting of the planar joint into the combination of three simple X joints according to [3] (the values of the forces were taken from the simplified beam model of the frame)

The compressed brace 1 (marking according to Fig. 2) has a decisive impact on the joint’s load-bearing capacity, and its resultant efficiency achieved the values:

- $t_0 = 7,1 \text{ mm} - \sum \frac{N_{Ed,1,i}}{N_{Rd,1,i}} = 1,224 \geq 1,0$
... the criteria are not satisfied. ($N_{Rd,1} = 376 \text{ kN}$)
- $t_0 = 8,0 \text{ mm} - \sum \frac{N_{Ed,1,i}}{N_{Rd,1,i}} = 0,974 \leq 1,0$
... the criteria are satisfied. ($N_{Rd,1} = 473 \text{ kN}$)

The calculations of the individual load-bearing capacities were performed according to recommendations given by Wardenier et al. [3].

IV. NUMERICAL MODELING

The numerical models were created in the FEM software ANSYS 12.0 using the finite elements enabling non-linear calculations (both plastic behavior of materials and influence of large deformations). For modeling the CHS profiles the shell finite element SHELL 43 was used, defined by four nodes, four thickness values and orthotropic material properties. Model of the truss frame structure was made of the quadratic (3-node) beam element in 3-D – BEAM 189, which is defined by three nodes and a cross-section [4]. For the mutual connection of the elements BEAM and SHELL, the contact elements TARGE 170 (for pilot node on tip of beam interfacing with shell edge) and CONTA 175 (on the shell edge nodes) were used [5].

The following material properties were assigned to the finite elements (similar to [6], [7]): Young’s modulus of elasticity $E = 210 \text{ GPa}$ and Poisson’s ratio $\nu = 0.3$. The cross-sections I – VI according to Fig. 1 were assigned to the beam elements. Both physical and geometrical non-linear aspects were considered within the calculation (a plastic calculation with regard to large deformations). The elasto-plastic behavior of the material was expressed by a bilinear diagram (similar to e.g., [8]) with the value of yield stress $f_y = 355 \text{ MPa}$ and 5% hardening (i.e., with value of the tangent modulus $E_2 = 10 \text{ GPa}$).

Through the connection of two different types of finite elements – BEAM 189 and SHELL 43 – using aforementioned contact elements CONTA 175 and TARGE 170 and MPC (Multi-Point Constraints) algorithm (for more information see [9]), it was possible to specify boundary conditions (supports and loads) directly for the model of the truss frame (Fig. 4). The behavior of the analyzed joint was thus derived from the mutual effect of the structure’s individual elements, which is close to the real behavior, and so it was not necessary to seek out suitable boundary conditions for the separate detail (as in e.g., [10], [11]).

The forces acting on the lattice structure were based on the critical combination of the possible load situations.

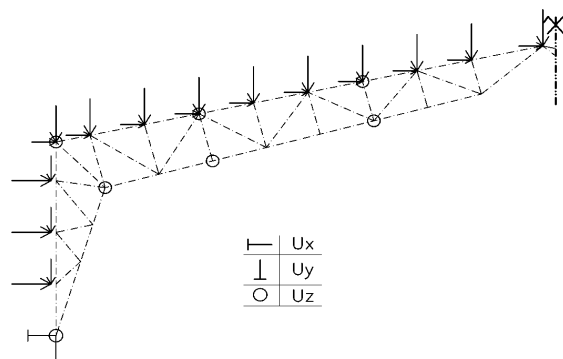

Fig. 4 Scheme of specified boundary conditions – supports, loads

V. RESULTS OF NUMERICAL MODELING

Two numerical models, which differ only in terms of the chord thickness ($t_0 = 7.1\text{mm}$ and $t_0 = 8\text{mm}$), were studied. The models were used to observe the dependency of the chord cross-section transverse deformation on the axial force in the compressed brace 1 (the most loaded joint member) – see Fig. 5. The course of these load - deformation curves was also

compared with the deformation limit according to [12], which is $0.01d_0$ (where d_0 is chord cross-section diameter) – corresponds to serviceability strength. According to that criterion the joint strength is $N_{Rd,1} = 348\text{ kN}$ (for thickness $t_0 = 7.1\text{mm}$) or $N_{Rd,1} = 414\text{ kN}$ (for thickness $t_0 = 8.0\text{mm}$) respectively.

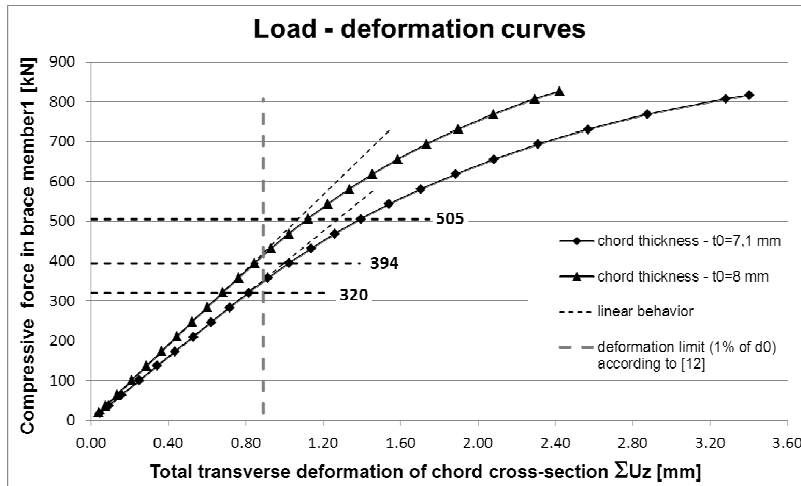

Fig. 5 Load-deformation curves for different chord wall thicknesses with the ultimate deformation limit value

In Figs. 6-8 can be observed the evolution of the stress beyond the yield stress value in three steps – the compressive force in brace member 1 reaches the level of 320 kN, 394 kN and 505 kN (see Fig. 5). These steps represent the points before and after reaching the deformation limit $0.01d_0$:

- 320 kN – joint with thickness $t_0 = 7.1\text{mm}$ is before reaching deformation limit;
- 394 kN – joint with thickness $t_0 = 8.0\text{mm}$ is before reaching deformation limit;
- 505 kN – both joints are beyond this deformation limit.

In the Table I values of the chord cross-section transverse deformation (U_z) are entered on in aforementioned steps.

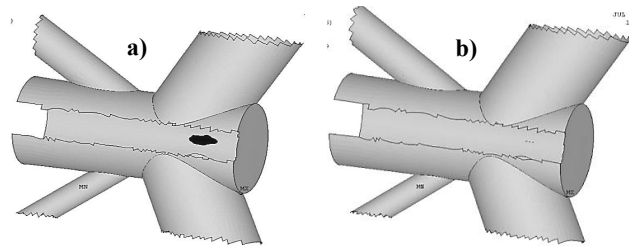

Fig. 6 Evolution of stress (von Mises) beyond the yield stress value when loaded with a force 320 kN in the brace member 1
a) chord wall thickness 7.1mm; b) chord wall thickness 8.0mm

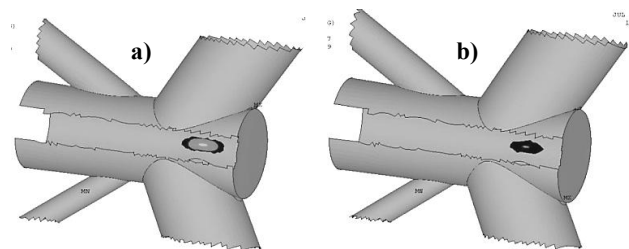

Fig. 7 Evolution of stress (von Mises) beyond the yield stress value when loaded with a force 394 kN in the brace member 1
a) chord wall thickness 7.1mm; b) chord wall thickness 8.0mm

TABLE I
TRANSVERSE DEFORMATION OF CHORD CROSS-SECTION

Deformed shape	t_0 [mm]	$N_{Ed,1}$ [kN]		U_z [mm]	$\Sigma U_z $ [mm]
	7,1	320	A	-0,404	0,814
			B	+0,410	
		394	A	-0,508	1,022
		B	+0,514		
	8,0	505	A	-0,694	1,394
			B	+0,700	
320		A	-0,338	0,681	
	B	+0,343			
	394	A	-0,421	0,846	
		B	+0,425		
	505	A	-0,559	1,112	
		B	+0,561		

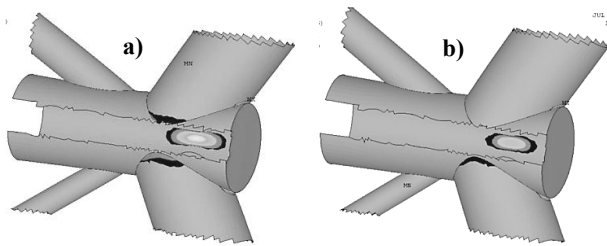

Fig. 8 Evolution of stress (von Mises) beyond the yield stress value when loaded with a force 505 kN in the brace member 1
a) chord wall thickness 7.1mm; b) chord wall thickness 8.0mm

VI. CONCLUSION

A numerical model was created of the 3D detail of the joint, which behavior, through the contact elements (CONTA 175 and TARGE 170), is derived from the overall behavior of the structure. This corresponds to real behavior of the structure. The way of the joint's deformation and evolution of plastic stress corresponds to the expected failure mode, i.e., chord plastification.

From the load-deformation curves in Fig. 5 it is evident at which load (value of the compressive force in brace member 1) the plastification of the individual joint model begins, i.e., where the curve start to deviate from the linear behavior. These values are virtually identical to the load values for the deformation limit $0.01d_0$, recommended in [12].

From the analytical assessment according to [3] it is evident that a significant change in the joint load-bearing capacity (increase by 25%) can be attained by a not overly significant change in chord wall thickness. Used analytical method is not new (year of publication – 2008), but it is not included in a code and is not widespread in practice. The obtained results agree well with the results from the FEM model, which advantage is primarily giving better overview and insight on the behavior of the joint. However, the analytical method can be used better in practice, mainly due to the time-consuming preparation of numerical models with heavy demands on software knowledge. The mismatch in the strengths calculated using both analytical and numerical models is about 10%. This can be explained by complexity of the FE model (influence of the additional bending moments at the joint due to semi-rigid connection of the members). It is also questionable if the limit of the first plastification at the joint is decisive for the joint load-bearing capacity. Nevertheless it was confirmed that the recommended deformation limit is good approximation of the beginning of non-linear behavior of the joint.

The research on similar steel joints problems will be further developed.

ACKNOWLEDGMENT

This research was financially supported by Project MŠMT - SP2013/169.

REFERENCES

- [1] Wardenier, J. *Hollow Sections in Structural Applications*. CIDECT, 2001. ISBN 0-471-49912-9
- [2] *EN 1993-1-8, Eurocode 3: Design of steel structures - Part 1-8: Design of joints*. 2005.
- [3] Wardenier, J., Kurobane, Y., Packer, J. A., van der Vegte, G. J., Zhao, X. - L.: *Design guide for circular hollow section (CHS) joint under predominantly static loading*. 2nd. CIDECT, Construction with hollow steel sections, 2008. ISBN 978-393-8817-032.
- [4] *Release 11.0 Documentation for ANSYS* [online]. [cit. 2013-7-15]. Available from <<http://www.kxcdn.net/ansys/ANSYS/ansyshelp>>
- [5] *Training Manual – Advanced Contact & Fasteners for ANSYS 11.0*. First Edition, Inventory number: 002580, Published: September 22, 2008.
- [6] Salem, A. H., Soliman, E. A., Ibrahim, S. A. and Fakhry, K. F. Strength of hollow section T-joints under bending moments. In *Proceedings of Twelfth International Colloquium on Structural and Geotechnical Engineering*. Cairo - Egypt: Ain Shams University, 2007
- [7] Jurčíková, A., Rosmanit, M.: FEM Model of Joint Consisting RHS and HEA Profiles. In: *STEEL STRUCTURES AND BRIDGES 2012: 23rd Czech and Slovak International Conference*. Podbanské, září 2012. Procedia Engineering, Volume 40, 2012, s. 6. ISSN 1877-7058. Dostupné z: <http://www.sciencedirect.com/science/article/pii/S1877705812024630>
- [8] Bittencourt, M. C. , de Lima, L. R. O., Vellasco, P. C. G. da S., da Silva, J. G. S., Neves, L. F. da C.: A numerical analysis of tubular joints under static loading. In *Proceedings of APCOM'07 in conjunction with EPMESC XI*, Kyoto, Japan. December 3-6, 2007.
- [9] Jurčíková, A., Rosmanit, M.: Interconnection of the 3D joint detail and the beam model of structure using the MPC algorithm. In: *Modelování v mechanice 2013: [mezinárodní konference]*, Ostrava, květen 2013. Ostrava: VŠB - Technická univerzita Ostrava, 2013. ISBN 978-80-248-2694-3. In Czech language.
- [10] Vegte, G. J. van der, Makino, Y., Wardenier, J. The influence of boundary conditions on the chord load effect for CHS gap K-joints. In *Connections in Steel Structures*. Amsterdam. June 3-4, 2004.
- [11] Choo, Y. S., Qian, X. D., Wardenier, J. Effects of boundary conditions and chord stresses on static strength of thick-walled CHS joints. In *Journal of Constructional Steel Research*. April 2006, Volume 62, Issue 4, Pages 316–328. ISSN 0143-974X.
- [12] Lu, L. H., Winkel, G. D. de, Yu, Y., and Wardenier, J.: Deformation limit for the ultimate strength of hollow section joints. In: *Proceedings 6th International Symposium on Tubular Structures*, Melbourne, Australia, 1994.