

The Establishment and Application of TRACE/FRAPTRAN Model for Kuosheng Nuclear Power Plant

S. W. Chen, W. K. Lin, J. R. Wang, C. Shih, H. T. Lin, H. C. Chang, W. Y. Li

Abstract—Kuosheng nuclear power plant (NPP) is a BWR/6 type NPP and located on the northern coast of Taiwan. First, Kuosheng NPP TRACE model were developed in this research. In order to assess the system response of Kuosheng NPP TRACE model, startup tests data were used to evaluate Kuosheng NPP TRACE model. Second, the overpressurization transient analysis of Kuosheng NPP TRACE model was performed. Besides, in order to confirm the mechanical property and integrity of fuel rods, FRAPTRAN analysis was also performed in this study.

Keywords—TRACE, Safety analysis, BWR/6, FRAPTRAN.

I. INTRODUCTION

THE advanced thermal hydraulic code named TRACE has been developed by U.S. NRC for NPP safety analysis. According to the TRACE manual [1], one of the features of TRACE is its capacity to model the reactor vessel with 3-D geometry. It could support a more accurate and detailed safety analysis for NPPs. TRACE has the greater simulation capability than other old codes (TRAC-P, TRAC-B, RELAP5 and RAMONA), especially for events such as LOCA.

FRAPTRAN is a Fortran language computer code that calculates the transient performance of light-water reactor fuel rods during reactor transients and hypothetical accidents such as loss-of-coolant accidents, anticipated transients without scram, and reactivity-initiated accidents [2]. SNAP is a graphic user interface program which processes inputs, outputs, and the animation model for TRACE and FRAPTRAN.

Kuosheng NPP's nuclear steam supply system is a type of BWR/6 designed and built by General Electric on a twin unit concept. Each unit includes two loops of recirculation piping and four main steam lines, with the thermal rated power of 2894MWt.

This research focuses on the establishment of Kuosheng NPP TRACE/SNAP and FRAPTRAN/SNAP models. Kuosheng NPP TRACE/SNAP model included one 3-D vessel, six channels which were used to simulate 624 fuel bundles, four steamlines, and 16 SRVs components, etc.. The containment and suppression pool were also simulated in TRACE/SNAP model. In order to assess the system response of Kuosheng NPP TRACE/SNAP model, this study used startup tests data to

evaluate Kuosheng NPP TRACE/SNAP model. The load rejection and a feedwater pump trip transients were selected to validate Kuosheng NPP TRACE/SNAP model.

According to FSAR [3], the overpressurization transient is one of the most limiting of transients. Therefore, the overpressurization transient analyses were performed in order to estimate the thermal-hydraulic and fuel rods performance. Finally, TRACE's analysis results (ex: power and coolant data) were used in FRAPTRAN's input files. FRAPTRAN can calculate the cladding temperature, hoop stress/strain, oxide thickness of cladding of the fuel rods. Besides, the animation model of Kuosheng NPP was presented using the animation function of SNAP with TRACE and FRAPTRAN results.

II. TRACE AND FRAPTRAN MODELS

SNAP v 2.2.7, TRACE v 5.0p3, and FRAPTRAN v1.4 were used in this research. Kuosheng NPP TRACE/SNAP model (Fig. 1) has been built according to FSAR, design documents, and TRACE manuals [1], [3]-[6]. Kuosheng NPP reactor was simulated by the 3-Dvessel component which was divided into two azimuthal sectors, four radial rings, and eleven axial levels. Six channels (one dimensional component) were used for simulating 624 fuel bundles. Full length fuel rods, partial length fuel rods and water rods were also simulated in channel components. Two recirculation loops were set outside the reactor, with a recirculation pump in each loop. 10 groups of jet pumps were merged into an equal jet pump. Four steam lines connected with the vessel and each steam line had one MSIV (main steam line isolation valve), several SRVs (safety relief valves), one TCV (turbine control valve), and one TSV (turbine stop valve). The bypass valve (BPV) was also simulated in this mode. We used valve components to simulate MSIV, SRVs, TCV, TSV and BPV. The critical flow models for MSIVs, SRVs, TCVs, TSVs, and BPV had been considered in our model. The containment of Kuosheng NPP was also simulated in TRACE/SNAP model. The containment was composed of drywell, wet well, suppression pool, vent annulus, horizontal vent, upper pool, and reactor building which were shown in Fig. 1. In Kuosheng NPP TRACE/SNAP model, there were three simulation control systems: (1) feed water flow control system, (2) steam bypass and pressure control system and (3) recirculation flow control system. Besides, in Kuosheng NPP TRACE/SNAP model, "point kinetic" parameters such as delay neutron fraction, Doppler reactivity coefficient, and void reactivity coefficient were provided as TRACE input for power calculations.

S.W. Chen, W.K. Lin, J. R. Wang, C. Shih, H. C. Chang, W.Y. Li are with the Institute of Nuclear Engineering and Science, National Tsing-Hua University, R.O.C., Taiwan (e-mail: chensw@mx.nthu.edu.tw).

H.T. Lin is with the Institute of Nuclear Energy Research, Atomic Energy Council, R.O.C., Taiwan (e-mail: htlin@iner.gov.tw).

The geometry data of the fuel rod and the results from TRACE analysis (fuel rod power, coolant pressure, heat transfer coefficient data) were inputted into FRAPTRAN to analyze the reliability of fuel rod. In FRAPTRAN model (see Fig. 2), node 1 is the bottom of the fuel rod and node 12 is the top of the fuel rod. Finally, SNAP used TRACE and FRAPTRAN results data to make an animation, such as Fig. 3.

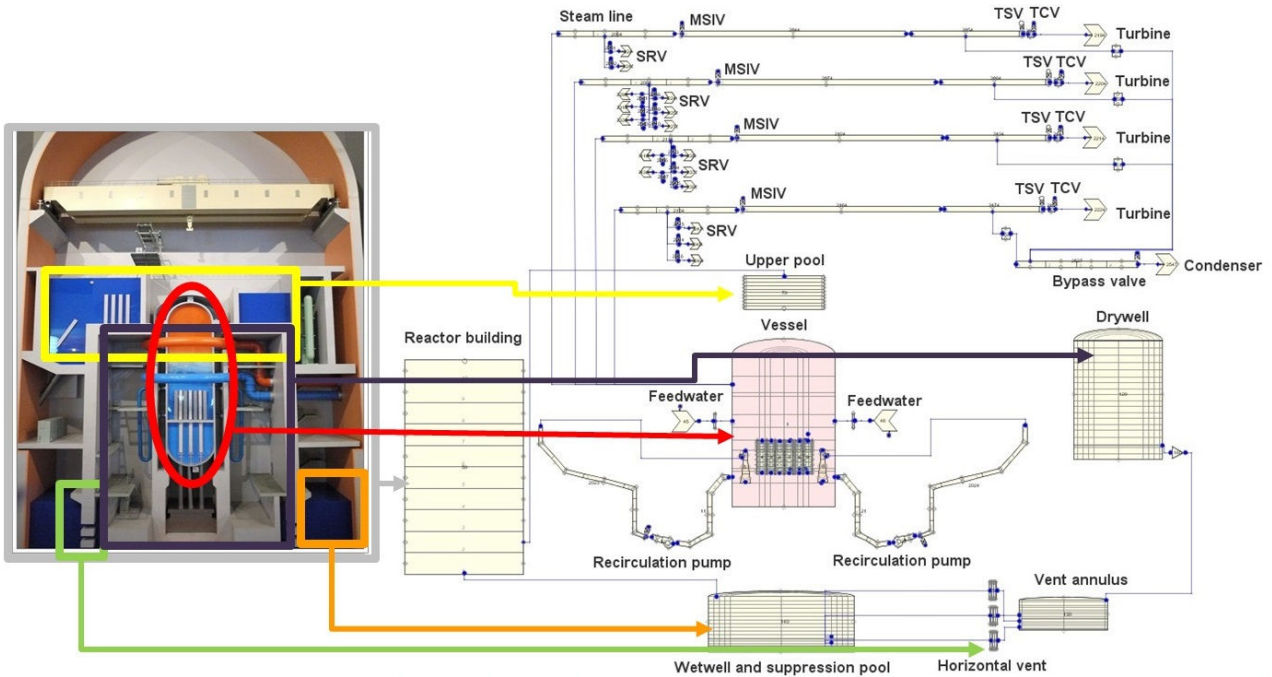

Fig. 1 TRACE/SNAP model of Kuosheng NPP

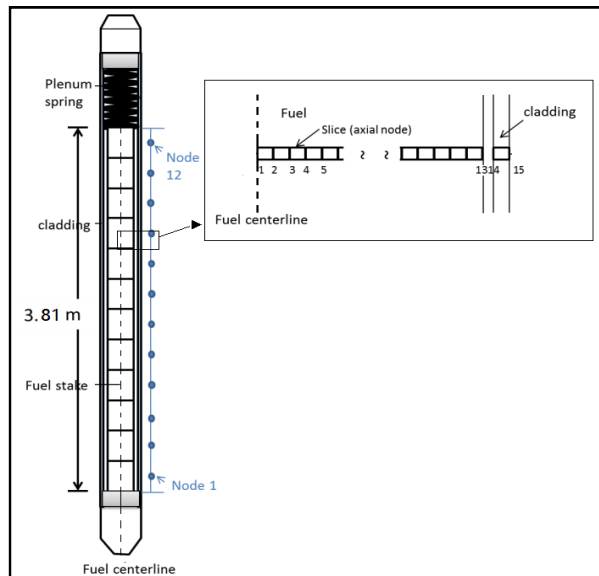

Fig. 2 FRAPTRAN model of Kuosheng NPP

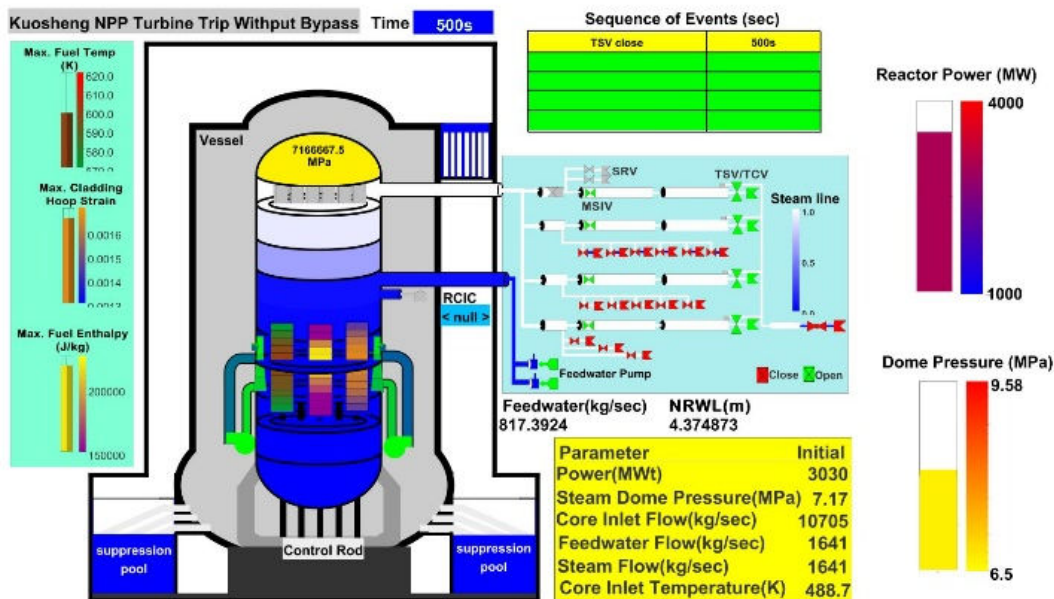

Fig. 3 SNAP animation model of Kuosheng NPP

III. RESULTS

Before the transient analysis of Kuosheng TRACE/SNAP model begins, it is necessary to carry out the steady state calculation and make sure that the system parameters (such as the feedwater flow, steam flow, dome pressure, and core flow, etc.) are in agreement with startup tests data. The results of analysis of TRACE were clearly consistent with startup tests data (See Table I).

TABLE I
THE COMPARISON OF INITIAL CONDITIONS BETWEEN STARTUP TESTS AND TRACE DATA

Parameter	Startup tests	TRACE	
		Point kinetics	Difference (%)
Power (MWt)	2894	2894	0
Dome Pressure (MPa)	7.3	7.3	0
Feedwater Flow (kg/sec)	1647	1652	-0.3
Steam Flow (kg/sec)	1647	1652	-0.3
Core inlet flow (kg/sec)	10647	10521	1.2

Startup test (load rejection with bypass valves) was performed in November 11, 1981 and the initial power was 2894 MWt. The purpose of the test was to confirm the functions of TCVs, BPV, SRVs and the response of system. Table II compares load rejection with bypass valves transient's sequences of startup test with TRACE. Their sequences were very similar. In this transient, when load rejection occurred, TCV closed quickly. Then BPV opened and reactor scrammed. When the water level reached level 3, recirculation pumps were tripped. Finally, BPV was reset at 6.48 MPa.

TABLE II
THE COMPARISON OF SEQUENCES BETWEEN STARTUP TEST AND TRACE DATA

Event(sec)	Startup test	TRACE
Transient started	0	0
TCV started to close	0.2	0.2
BPV started to open	0.21	0.21
Reactor scrammed	0.236	0.236
BPV fully opened	0.329	0.329
TCV fully closed	0.394	0.394
Water level reached level 3	2.2	3.1
Steam dome pressure peak	3.9 (7.43 MPa)	2.5 (7.36 MPa)
BPV reset at 6.48 MPa	16.3	18.4
End of analysis	-	20

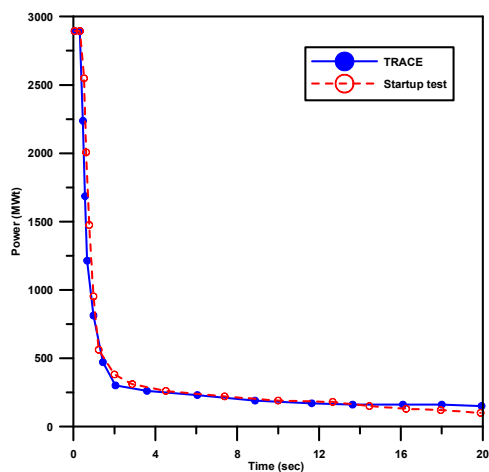

Fig. 4 The power data of TRACE and startup test

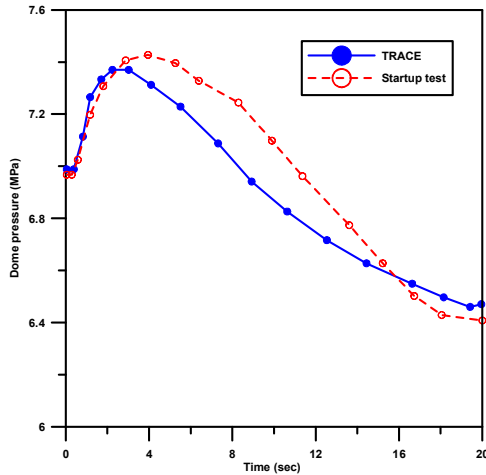

Fig. 5 The dome pressure data of TRACE and startup test

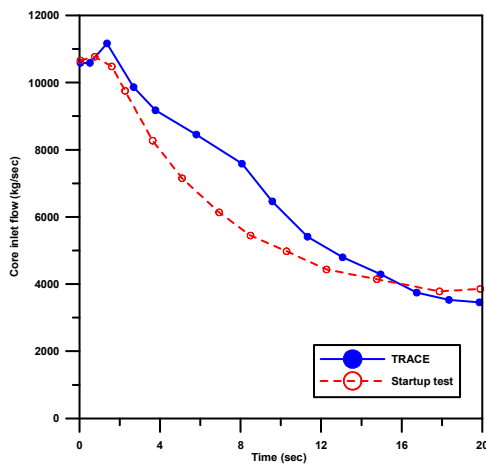

Fig. 6 The core inlet flow data of TRACE and startup test

Figs. 4~6 show the results of startup test and TRACE. Fig. 4 depicts the power curves of startup test and TRACE. The trends of their curves were similar. TCV fast closure tripped the reactor scram. Therefore, the power dropped after 0.3 sec. Fig. 5 compares the steam dome pressures of startup test and TRACE. The trends of the curves were approximately in agreement. TCV closing caused the dome pressure to rise. Then, BPV and SRVs opened and led to the decline of dome pressure. Due to the dome pressure increase, it resulted in the core inlet flow rising during 0.5~2 sec (see Fig. 6). In other parameters comparisons (like steam flow, feedwater flow, and water level), their trends were also similar. Then, recirculation pumps trip caused the decrease of core inlet flow. In summary, the trends of TRACE prediction were consistent with startup test data but there were a few differences in the values of the prediction. Because we cannot find the detailed startup test data, we don't know what the reasons cause the differences of TRACE results and startup test data.

Startup Test (one feedwater pump trip) was performed in November 6, 1981 and the initial power was 2778 MWt. The purpose of the test was to confirm the function of FCV (flow

control valve) when one feedwater pump tripped. Table III shows the one feedwater pump trip transient's sequences of startup test and TRACE. Their sequences were nearly the same. In this transient, after one feedwater pump tripped, the water level decreased. When the water level reached level 4, FCV runback was started. Then, the power and core flow decreased.

TABLE III
THE COMPARISON OF SEQUENCES BETWEEN STARTUP TEST AND TRACE

Action (sec)	Startup test	TRACE
Transient Started	0	0
One feedwater pump tripped	4.9	4.9
Water level dropped to level 4	15.1	15.4
Minimum power value	18.5 (57%)	18.5 (57%)
Minimum core flow	19.4 (79.3%)	18.7 (77%)
End of analysis	-	30

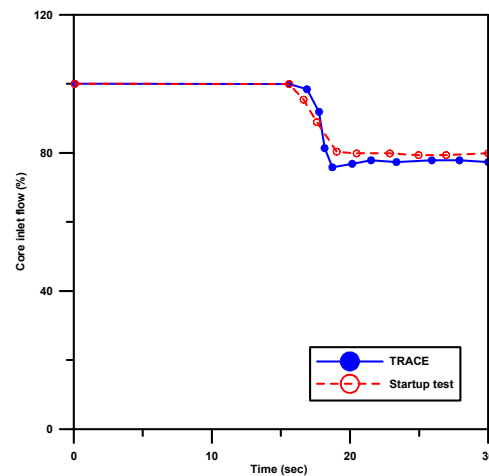

Fig. 7 The core inlet flow data of TRACE and startup test

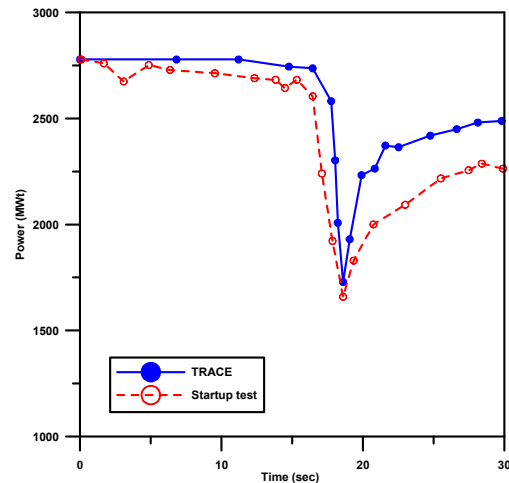

Fig. 8 The power data of TRACE and startup test

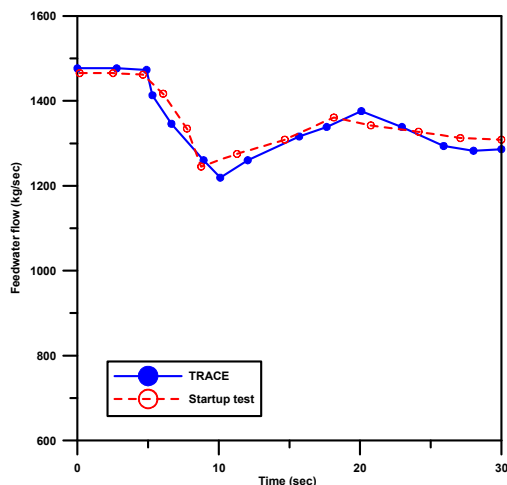

Fig. 9 The feedwater flow data of TRACE and startup test

Figs. 7~9 show the results of startup test and TRACE. Fig. 7 presents the core inlet flow curves of startup test and TRACE. The trends of their curves were similar. One feedwater pump trip caused the water level decrease. FCV runback was tripped when the water level reached level 4. Therefore, the core inlet flow decreased due to FCV runback. Fig. 8 compares the powers of startup test and TRACE. The trends of the curves were approximately in agreement. After FCV runback, the power decreased. Fig. 9 shows the feedwater flow data of startup test and TRACE. TRACE result was consistent with startup test data. One feedwater pump trip caused the feedwater flow to decrease after 4.9 sec. Besides, the NRWL result of TRACE was similar to startup test data. In summary, the results of TRACE prediction were similar to startup test but there were a few differences in the values of parameters.

By the above TRACE and startup tests comparisons, it indicates that there is a respectable accuracy in Kuosheng NPP TRACE/SNAP model. According to FSAR [3], the overpressurization transient is one of the most limiting of transients. Therefore, we used Kuosheng NPP TRACE/SNAP model to perform the overpressurization transient analyses. On the basis of American Society of Mechanical Engineers (ASME) definition, the overpressurization transient analysis includes Main Steam Line Isolation Valve Closure (MSIVC), Turbine Stop Valve Closure (TSVC), Turbine Control Valve Closure (TCVC) transients. According to ASME provisions, the maximum dome pressure of all overpressurization cases should be lower than the acceptance limit 9.58 MPa.

In MSIVC hypothetical transient, we first executed 210-second steady state simulation. At the time point 210 second, MSIVs started to close. To keep the conservative degree, the closure time of MSIV is 3 second, which is shorter than the set-point in reality. There are two reactor scram signal resources, one is the neutron flux and the other is the dome pressure. As the neutron flux reaches to the 122% of the nominal scale, the reactor scrams. Similarly, when the dome pressure reaches to 7.66 MPa, the reactor will also scram in this analysis. According to the data results, the neutron flux reached to the set-point first and ended up the reaction.

TABLE IV
SEQUENCE AND SET-POINTS OF MISVC TRANSIENT

Time(second)	Time sequence	Set points
0~210	Steady state	
210	MSIV started to close	3 seconds from fully open to fully close
213	MSIV fully closed	
213.14	Reactor scram signal	Neutron flux reached to 122% of nominal scale
213.23	Reactor scrammed	Delayed time 0.09 second
213.46	Recirculation pumps tripped	Dome pressure 7.82 MPa
214.53	Group 1 safety valves opened	Dome pressure 8.38MPa Delayed time 0.4 second
214.65	Group 2 safety valves opened	Dome pressure 8.48 MPa Delayed time 0.4 second
214.73	Group 2 safety valves opened	Dome pressure 8.55 MPa Delayed time 0.4 second
220	Analysis ended	

Once MSIVs closed, the dome pressure increased immediately. In order to reduce the dome pressure, there were 11 safety valves that would open and release steam. These safety valves were divided into three groups with different set-point. Set-point of Group 1 is 8.38 MPa for 2 valves, set-point of Group 2 is 8.48 MPa for 5 valves and set-point of Group 3 is 8.55 MPa for 4 valves. According to the FSAR of Kuosheng NPP, the safety valves would really open with 0.4 delayed time after they got the signal. Furthermore, it costs 0.15 second to fully open the safety valves. Once the safety valves opened, the dome pressure would decrease slowly. Table IV shows the sequence and components set-point of this MISVC transient. At time point 213 second, MSIVs fully closed, the steam could not be released and as a result the dome pressure increased. Dome pressure increasing reduced the void fraction of the reactor core and the reaction got positive responsibility, as shown in Fig. 10. In addition, Fig. 10 also marked the reactor scram conditions, the 122% nominal scale of neutron flux and dome pressure 7.66 MPa. According to this figure, it shows that the neutron flux reached to the set-point first. The reactor scrammed due to the neutron flux limitation. Thought the reactor had scrammed, the dome pressure still increased until it reached to 8.38 MPa, set-point of safety valves group 1, at time point 214.53 second. Then the safety valves group 2 and group 3 also opened each at time point 214.65 and 214.73 second. Due to the safety valves open, the steam flow increased; as a result, the dome pressure decreased rapidly. However, once the dome pressure decreased to the set-point of safety valves, the safety valves would close and cause the dome pressure increased again. Then, this increasing of the dome pressure may cause the closed safety valves open again. With this dynamic balance, the dome pressure would slowly reached to a steady value. Fig. 11 shows the relationship between dome pressure and steam flow, which is the summation results of safety valves action. In this TRACE analysis of MSIVC transient, the dome pressure was always under the limitation 9.58 MPa, which indicated that the NPP was safe in this transient.

However, TRACE results cannot show the fuel rods details. Thus, the power, heat transient coefficients, and coolant conditions came from TRACE were entered into FRAPTRAN

to do further analysis.

The cladding temperature increased after 213 second as shown in Fig. 12 due to the increasing of core power. This increasing of cladding temperature would influence the cladding hoop strain, which is an important criterion of fuel rods integrity. As shown in Fig. 13, the cladding hoop strain has a vibration trend. This trend comes from the standoff between thermal hoop strain and elastic hoop strain. In the beginning of transient state, MSIVs closed and caused the dome pressure increasing. The cladding was pressed; as a result, the cladding shrank and elastic hoop strain decreased. Then, the cladding temperature increased and led to the cladding expanding at 215 second which implied the thermal hoop strain increase. The cladding total hoop strain was in a decreasing trend in this hypothetical accident analysis; NUREG-0800 Standard Review Plan [7] clearly defines fuel cladding failure criteria. For the uniform strain value, it is limited not to exceed 0.01. Furthermore, the total hoop strain was never over the limitation 0.01.

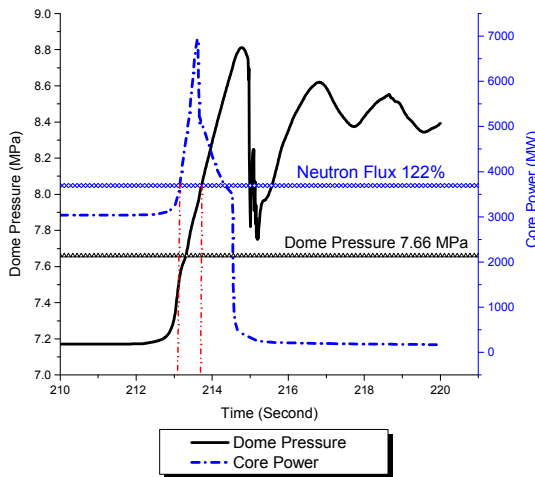

Fig. 10 Relationship between dome pressure and core power in MSIVC case

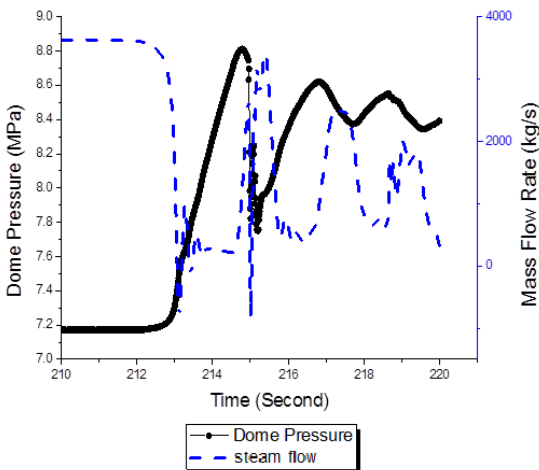

Fig. 11 Relationships between dome pressure and steam flow in MSIVC case

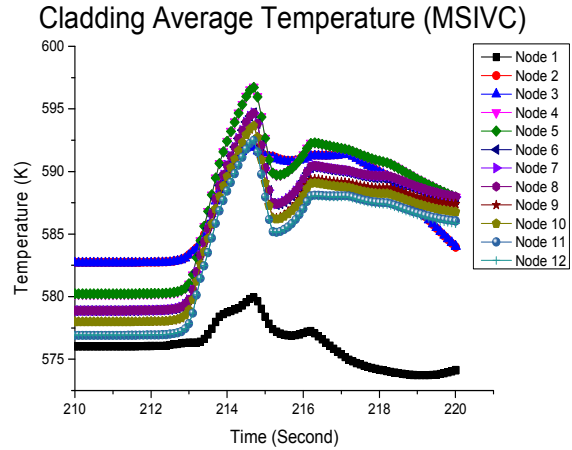

Fig. 12 Cladding temperature of fuel rods in MSIVC case

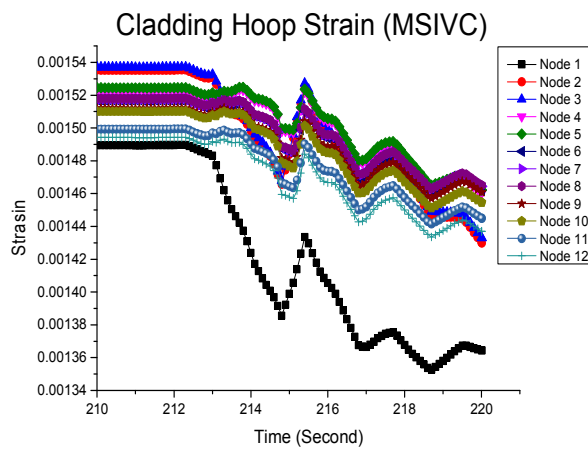

Fig. 13 Cladding hoop strain of fuel rods in MSIVC case

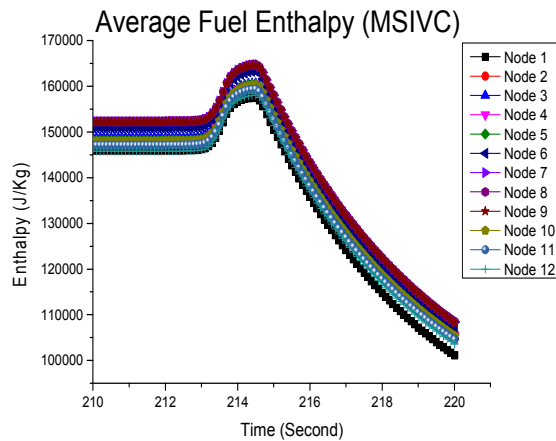

Fig. 14 Average fuel enthalpy of fuel rods in MSIVC case

In addition to the cladding hoop strain, the fuel pellet enthalpy is also an important criterion in the overpressurization analysis. Fig. 14 shows that the enthalpy peak value of MISVC analysis is about 165000 J/kg (39.47 cal/g). This value is much lower than the criteria 170 cal/g [7]. From these two results

above, we can infer that the fuel rods kept good integrity in the MSIVC hypothetical transient.

In this study, the TSVC hypothetical transient is divided into two parts. The first 500 second period was a steady state analysis. After the 500 second period, the turbines failed and caused the closure of TSVs. In general, once the TSVs start to close, the bypass valves start to open to relieve the pressure of the main steam lines. However, in this case, to simulate a more severe situation, the bypass valves do not open. The dome pressure increased continually until the safety relief valves (SRVs) opened and relieved the high pressure steam. Table V shows the sequence of the TSVC hypothetical transient.

The turbine trip caused the closure of TSVs, the dome pressure rising up; as a result, the void fraction of the reactor core was declined and neutrons in the reactor core got a positive reactivity. Hence, the power increased (as shown in Fig. 15). When the TSVs reached 90% open, the reactor scram and RPT were initiated. The reactor scram made the power dropped rapidly. On the other hand, closure of TSVs made the steam flow decrease rapidly. Then, the raising of vessel pressure increased the steam flow. However, because of the reactor scram, the vapor amount and steam flow were decreased again. Due to the ongoing rising of the vessel pressure, SRVs opened at the pressure 7.94 MPa; as a result, the steam flow increased again. For the dome pressure (see Fig. 16), in the beginning, the TSVs closure increased the pressure. When the pressure reached to 7.94 MPa, SRVs opened. As a result, the upward trend of pressure slowed down. In the whole transient process, vessel maximum pressure was 8.32 MPa, lower than the pressure limit 9.58MPa. It indicated that Kuosheng NPP was in the safe situation.

Figs. 17~19 show FRAPTRAN results. Fig. 17 depicts the cladding temperature results. The power dominated the cladding temperature. As shown in Fig. 18, the maximum of total cladding hoop strain is 0.00165, which is far less than acceptance limit 0.01, indicating that the cladding is safe in this case. In addition to the hoop strain, enthalpy is another important criterion of safety. From FRAPTRAN results, we can find that the maximum enthalpy is 52.44 cal/g (21930 J/Kg, Fig. 19), which is far less than 170 cal/g.

TABLE V
SEQUENCES AND SET-POINTS OF TSVC TRANSIENT

Time (second)	Action	Set point
0~500	Steady state	
500	TSVs started to close	0.1 second from fully open to fully close
500.09	Reactor scrammed	Initiated by the TSVs 90% open with delayed time 0.8 second
500.1	TSVs fully closed	
501.6	Safety/Relief valves opened	6 relief valves open initiated by dome pressure 7.94 MPa with delayed time 0.4 second
505	Analysis ended	

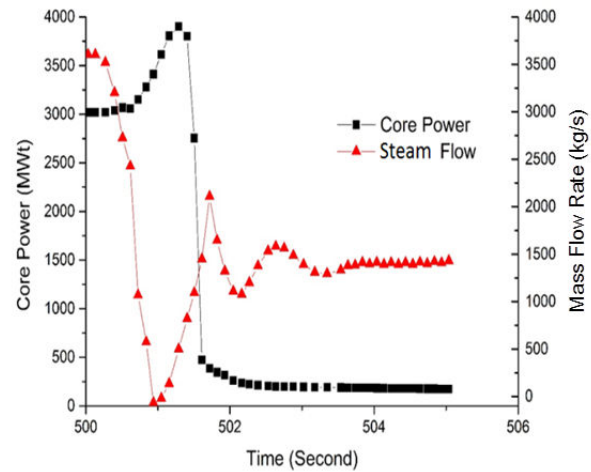

Fig. 15 Relationship between core power and steam flow in TSVC case

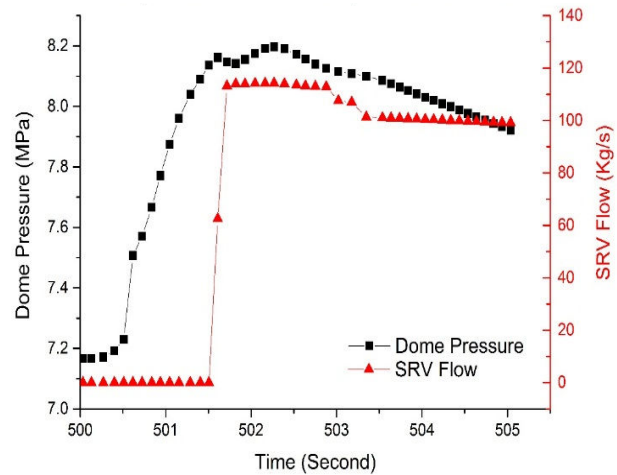

Fig. 16 Relationship between dome pressure and SRVs flow in TSVC case

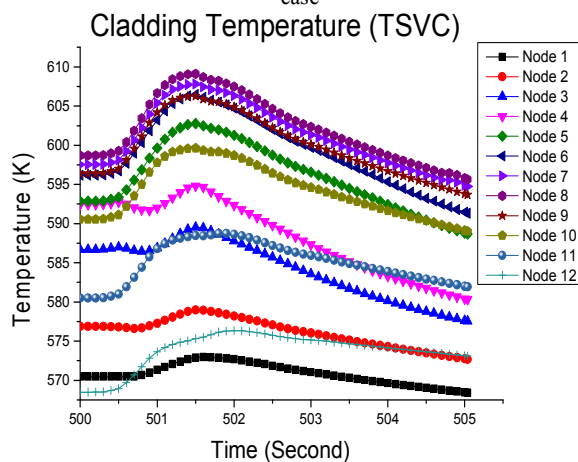

Fig. 17 Cladding temperature of fuel rods in TSVC case

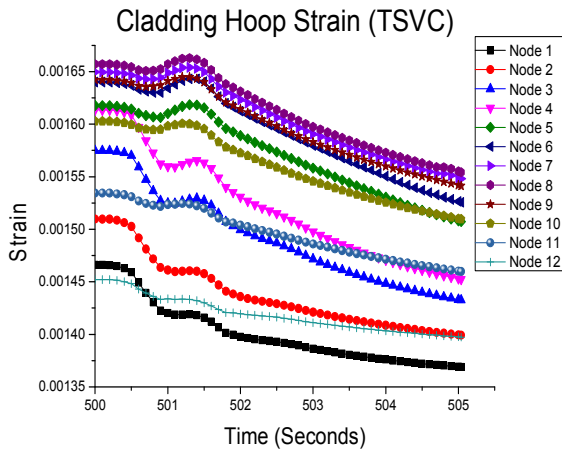

Fig. 18 Cladding hoop strain of fuel rods in TSVC case

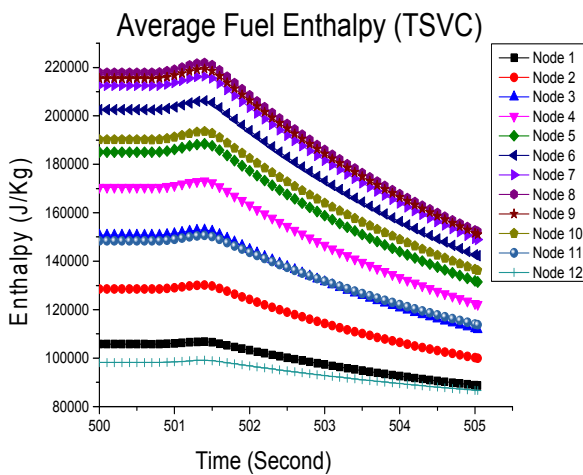

Fig. 19 Average fuel enthalpy of fuel rods in TSVC case

Table VI shows the sequences and the set-points of TCVC transient. TCVC hypothetical transient was initiated by the rapid closure of TCVs. When TCVs closed, the steam generated from the reactor core accumulated on the top of the reactor vessel. As a result, the dome pressure increased and led to the positive reactivity in the core. Then, the power went up.

As shown in Fig. 20, the steam flow decreased due to the TCVs closure. The steam did not be released so the dome pressure increased immediately. Fig. 21 shows the relationships between dome pressure and core power. As mentioned above, the increasing of dome pressure would reduce the void fraction and make the core power increase. Due to this increasing of core power, the reactor vessel generated more and more steam. As a result, the steam flow increased again at 211 second. For the safety reason, the control rods fully inserted at about 211.2 second and thus the core power decreased. Therefore, the steam generated inside the reactor vessel would be less so the steam flow decreased until the relief valves opened at 211.76 second. Once the relief valves opened, the dome pressure decreased and the NPP reached to a stable operating conditions.

In FRAPTRAN results, the peak value of cladding temperature, as shown in Fig. 22, is about 589K, which the

power dominates the cladding temperature. As shown in Fig. 23, the cladding hoop strain has a declined trend. This trend means that the elastic hoop strain is larger than the thermal hoop strain in this case. The dome pressure (coolant pressure) dominated the cladding deformation in this transient. Therefore, the cladding shrank and it would not expand or even rupture. However, the shrinkage might cause the pellet-cladding mechanical interaction (PCMI) so the radial gap should be concerned. Fig. 24 shows that the radial gap became larger despite the cladding shrinkage. It is because the fuel pellet also shrank due to the power reduction. Furthermore, the extent of pellet shrinkage is much more than that of cladding shrinkage. The radial gap increased and the PCMI would not happen in this transient.

In addition to the cladding hoop strain, the fuel enthalpy is also an important criterion. Fig. 25 shows that the enthalpy peak value of TCVC analysis is about 155000 J/kg (37.08 cal/g). This value is much lower than the criteria 170 cal/g. From these FRAPTRAN results above, it can be inferred that the fuel rods kept good integrity in TCVC hypothetical transient. Finally, by the animation function of SNAP with TRACE and FRAPTRAN analysis results, the animation of TSVC case was presented in Figs. 3 and 26.

TABLE VI
SEQUENCES AND SET-POINTS OF TCVC TRANSIENT

Time (second)	Action	Set point
0-209	Steady state	
210	TCVs started to close	0.15 second from fully open to fully close
210.07	Reactor scrammed	Initiated by the TCVs closure with delayed time 0.07 second
210.14	Recirculation pumps tripped	Initiated by the TCVs closure with delayed time 0.14 second
210.15	TCVs fully closed	
211.76	Safety/Relief valves opened	6 relief valves open with delayed time 0.4 second
215	Analysis ended	

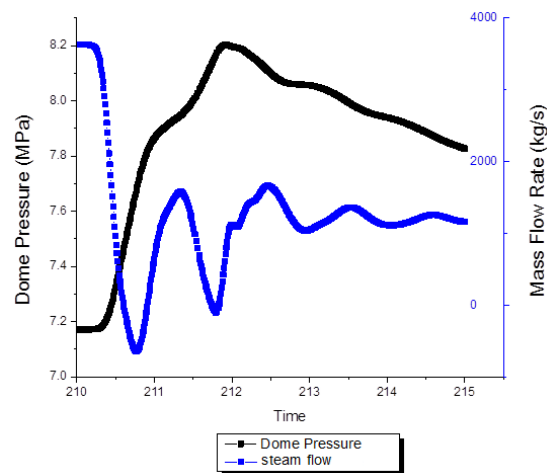

Fig. 20 Relationship between dome pressure and main steam line flow in TCVC analysis

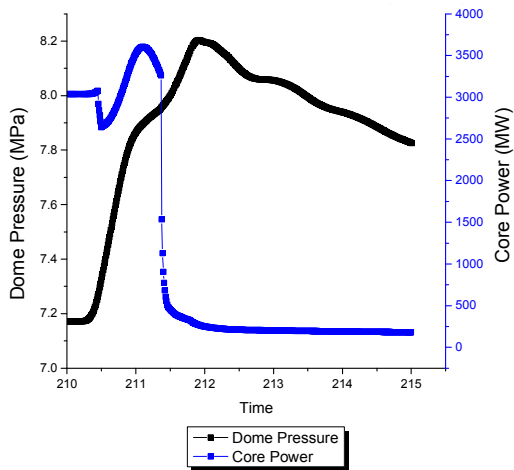

Fig. 21 Relationship between dome pressure and core power in TCVC analysis

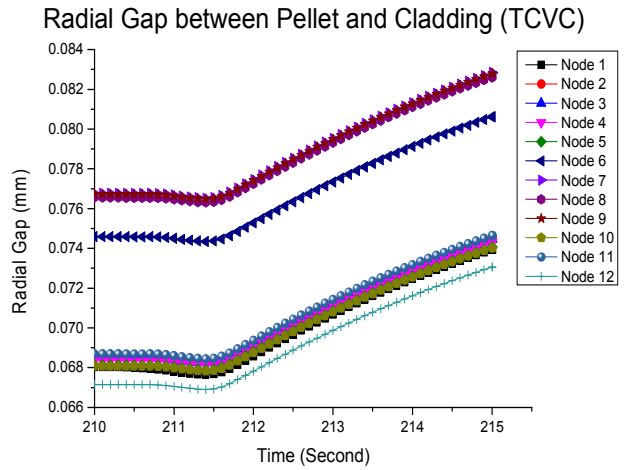

Fig. 24 Radial gap between pellet and cladding in TCVC analysis

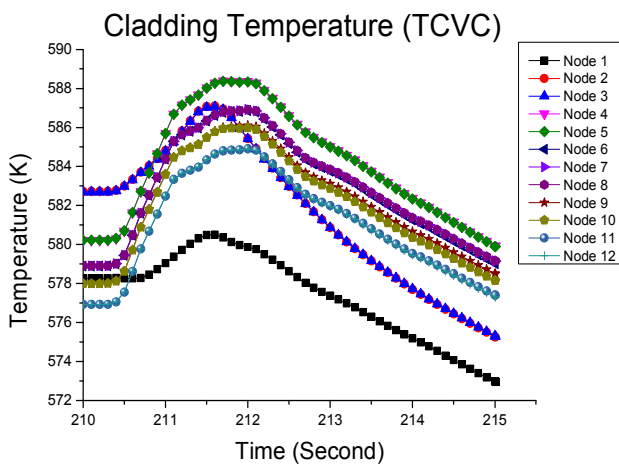

Fig. 22 Cladding temperature of fuel rods in TCVC analysis

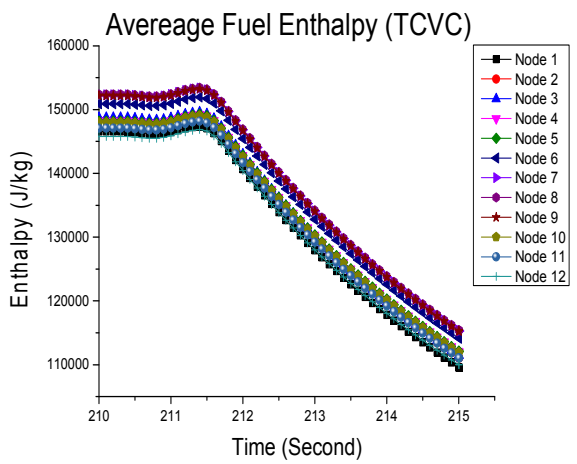

Fig. 25 Average fuel enthalpy of fuel rods in TCVC analysis

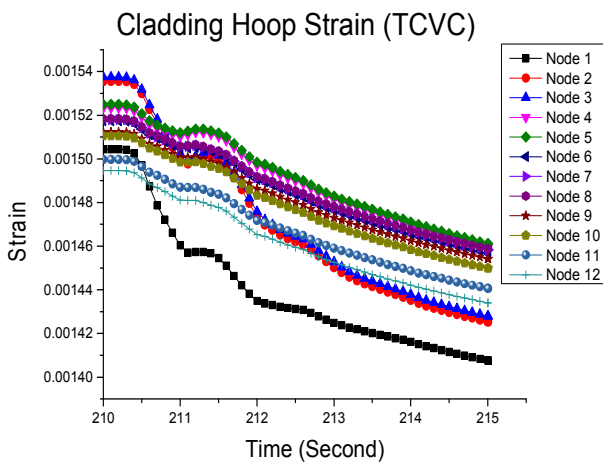

Fig. 23 Cladding hoop strain of fuel rods in TCVC analysis

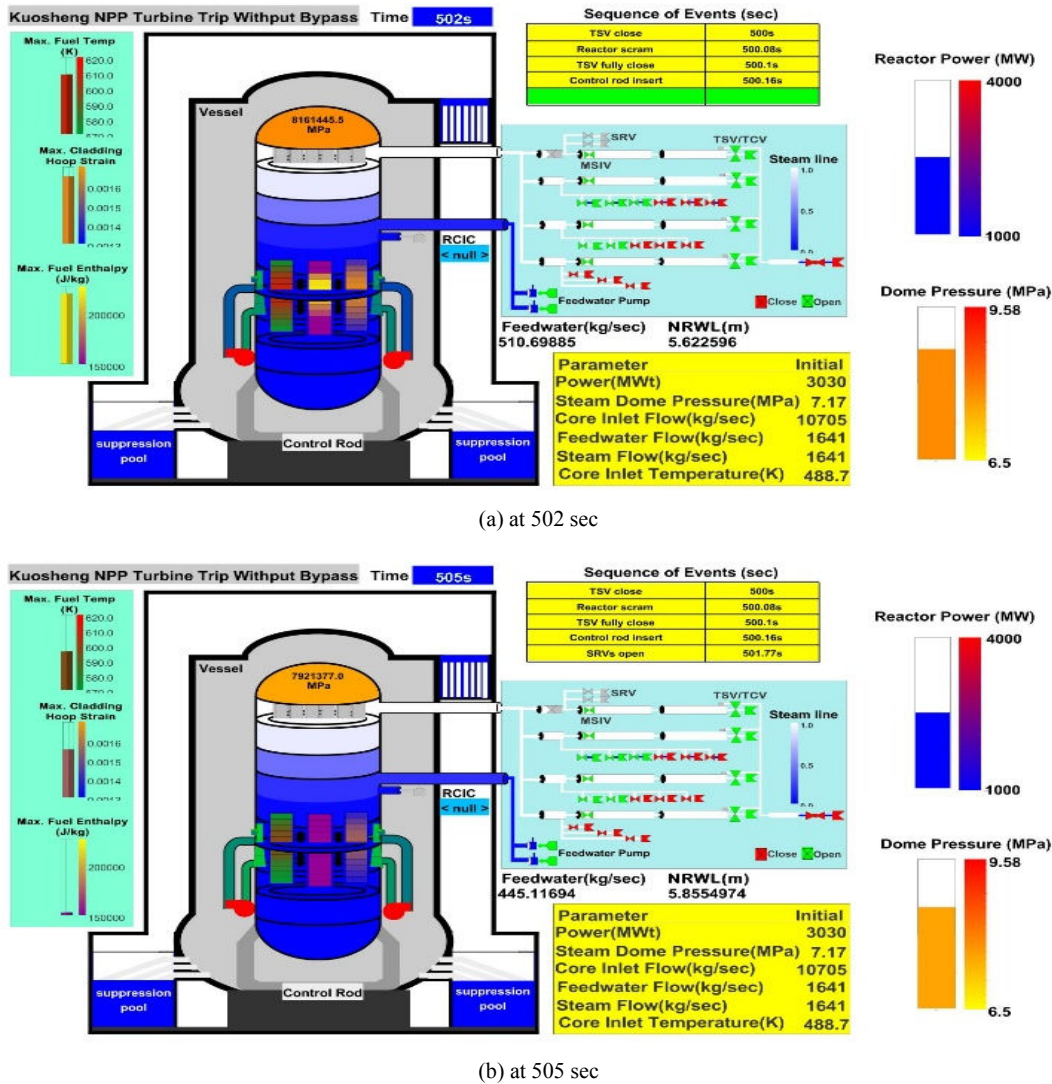

Fig. 26 SNAP animation model of Kuosheng NPP for TSVC case (a) at 502sec (b) at 505 sec

IV. CONCLUSION

Kuosheng NPP TRACE/SNAP and FRAPTRAN/SNAP models were established successfully in this research. The load rejection and a feedwater pump trip transients were selected to assess Kuosheng NPP TRACE/SNAP model. The results and sequences of TRACE were similar to startup tests data. By the above compared results, it indicates that there is a respectable accuracy in Kuosheng NPP TRACE/SNAP model and it also shows that Kuosheng NPP TRACE/SNAP model is satisfying for the purpose of Kuosheng NPP safety analyses with confidence.

In the overpressurization transient analysis, the dome pressures of all cases were lower than the limit (9.58 MPa). It implied that the NPP was in safe situation. Besides, FRAPTRAN results also indicated the fuel rods did not fail in overpressurization transients. Finally, TRACE and FRAPTRAN analysis results were presented by the animation model of Kuosheng NPP.

REFERENCES

- [1] NRC, "TRACE V5.0 User's Manual", Office of Nuclear Regulatory Research, 2010.
- [2] K. J. Geelhood, W. G. Luscher, C. E. Beyer and J. M. Cuta, "FRAPTRAN 1.4: A Computer Code for the Transient Analysis of Oxide Fuel Rods", NUREG/CR-7023, Vol. 1, 2011.
- [3] Taiwan Power Company, "Final Safety Analysis Report for Kousheng Nuclear Power Station Units 1&2 (FSAR)", 2001.
- [4] R. Y. Yuann, H. T. Lin, "Guideline of Generating Parameters for Reload Licensing Analyses for Kuosheng Units 1 and 2," INER report, INER-6529R, 2009.
- [5] K. Y. Lin, "Verification of the Kuosheng BWR/6 TRACE Model with Load Rejection Startup Test," ASME 2012 V&V, 2012.
- [6] J. R. Wang et al, "Kuosheng Startup Tests Transient Analyses," INER report, INER-0965, 1989.
- [7] U.S. NRC, "Standard Review Plan", NUREG-0800, 2007.